

Midrise Guideline

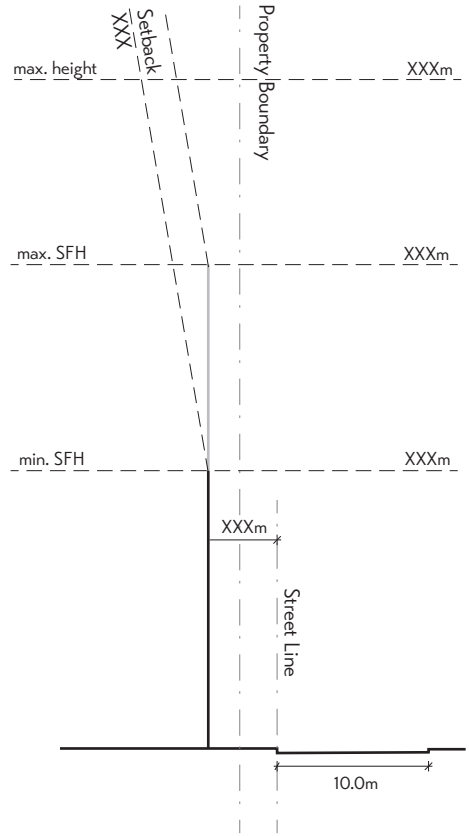

Tower Design

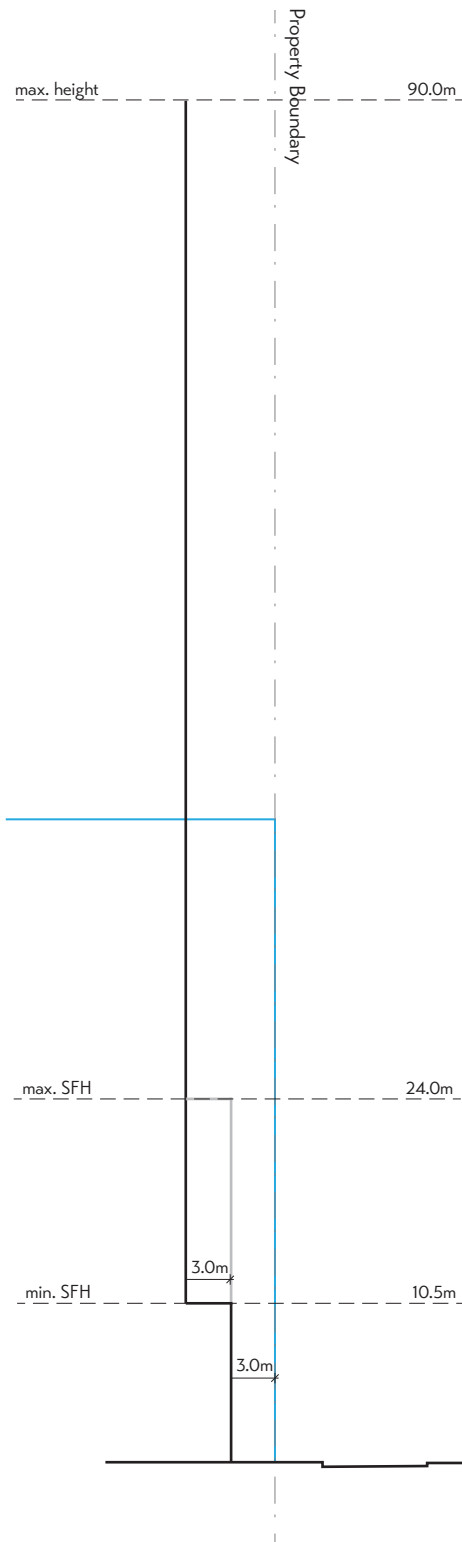

Podium Design

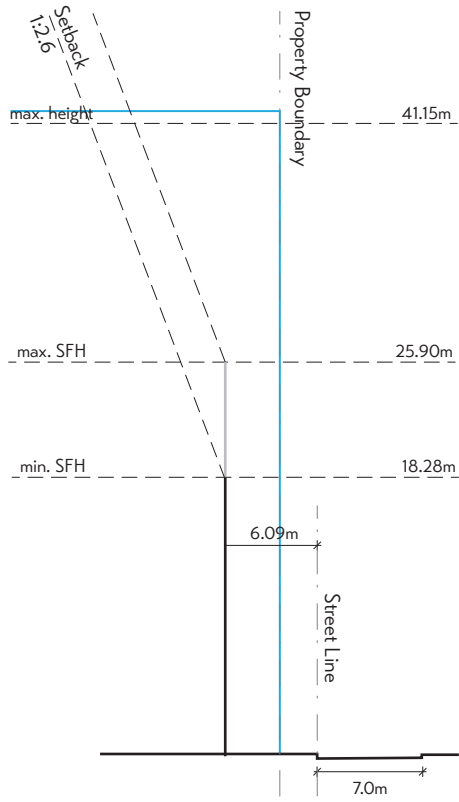

Narrow Street

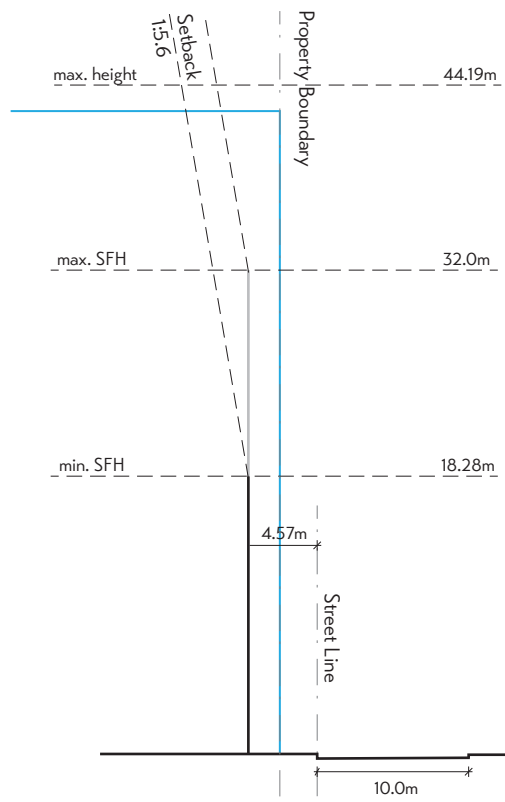

Wide Street

Tower Design

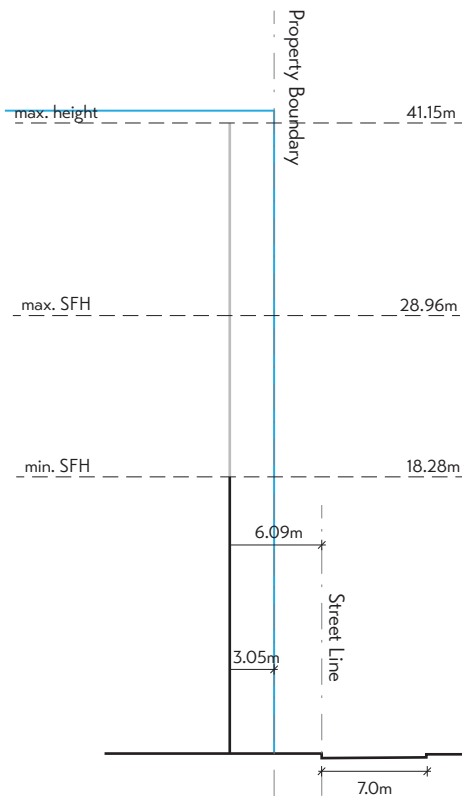

Narrow Street

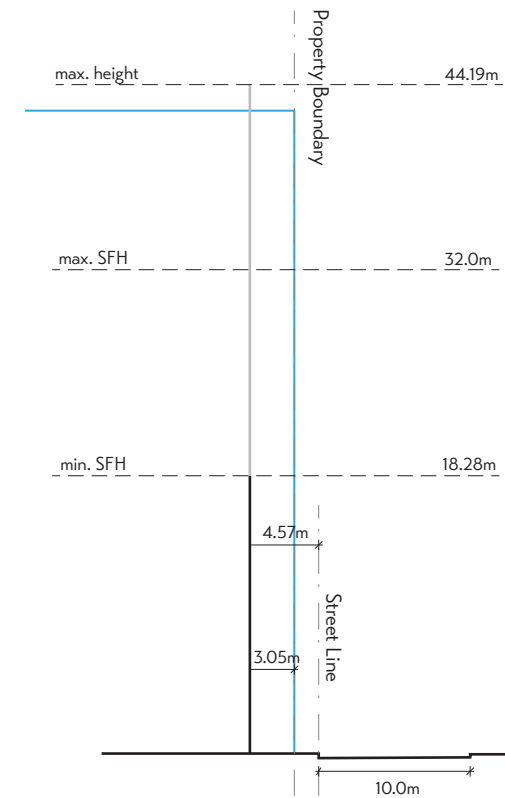

Wide Street

Tower Design

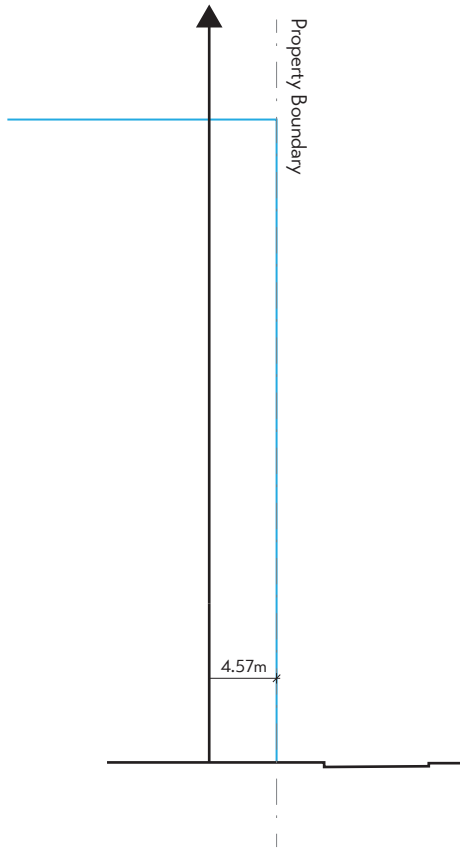

Tower Design

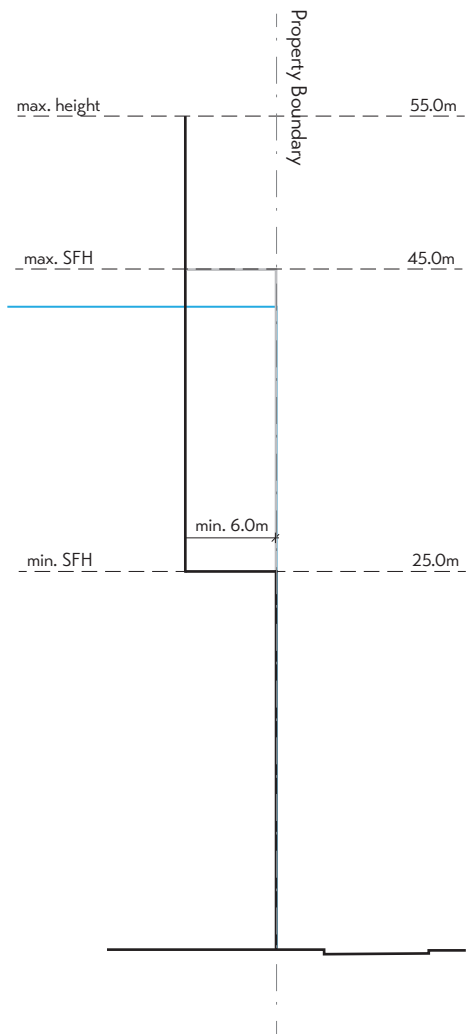

Business Zone

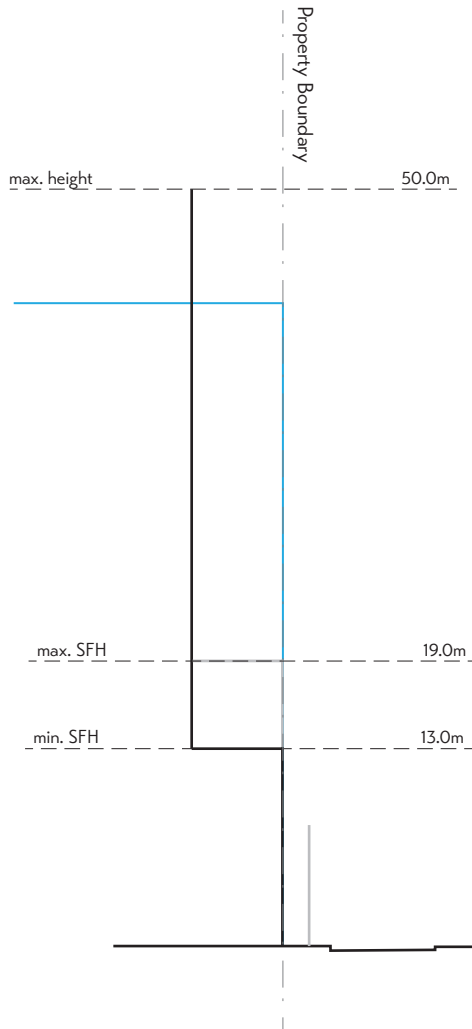

Mixed-Use Zone

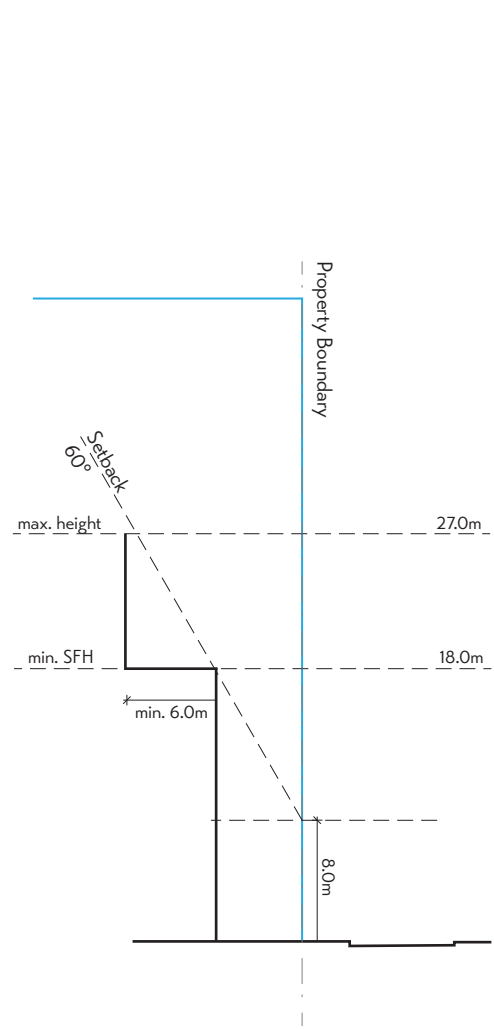

note: setback rule is based on an angle diagram which can be applied on a site-by-site basis

District Plan

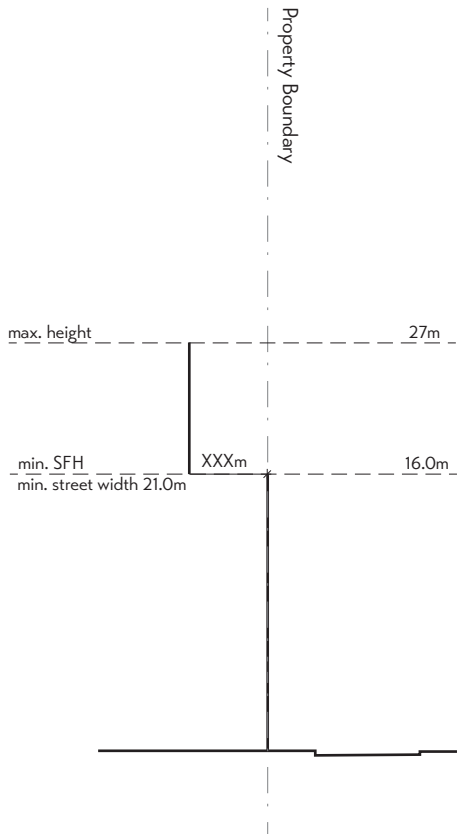

Proposed District Plan

