

PROPOSED DISTRICT PLAN CHANGE 77: *CURTIS STREET BUSINESS AREA*

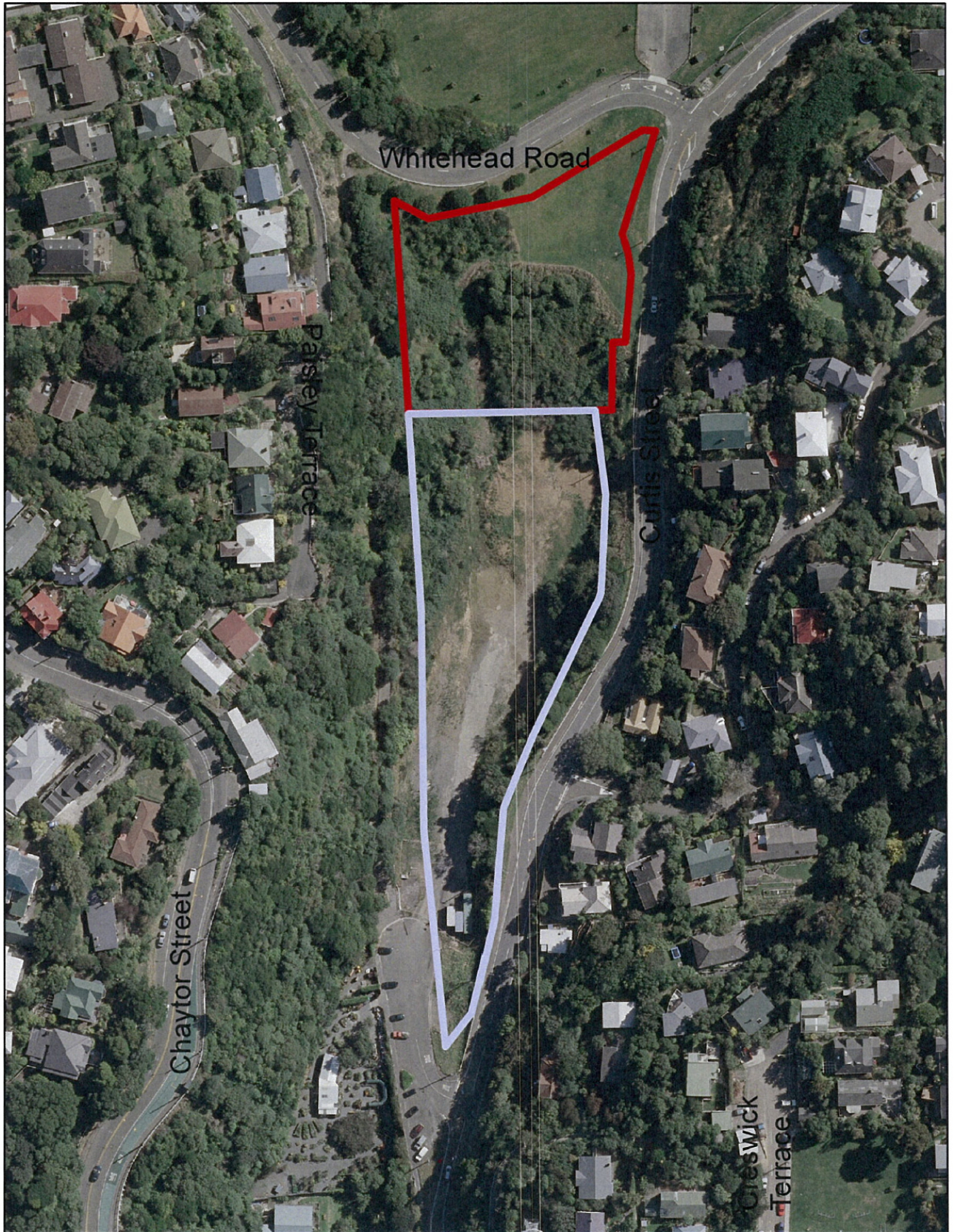

Plan Change Documents

December 2012

55-85 Curtis Street Karori



Proposed Zoning

-  Open Space B to Curtis Street Business Area
-  Outer Residential to Curtis Street Business Area

0 10 20 40 Meters

1:1,500



3. DISTRICT PLAN GENERAL PROVISIONS

Annotated provisions of Chapter 3 of the Operative District Plan showing proposed changes as part of Proposed District Plan Change 77.

Key to Changes:	
Abcdefghijklmnop	Existing unaltered text
Abcdefghijklmnop	Text to be deleted
<u>Abcdefghijklmnop</u>	Text to be added

Notes

1. A number of definitions from the Proposed Plan Changes 72 and 73 are repeated in this plan change.
2. When these definitions are settled under PC72, 73 and the current Proposed District Plan Change 77 and are identical the duplicate definitions will be removed. Where there are variations between the definitions they will be retained in their differing forms, with clear notes explaining which definition applies to particular sets of provisions.
3. The operative provisions of the District Plan will apply unless specifically provided for in Proposed District Plan Change 77.

3.10 Definitions

ANCILLARY RETAIL (FOR THE PURPOSE OF THE CURTIS STREET BUSINESS AREA): means a retail activity that is ancillary to the principal activity within the building or site, and comprises less than 10% of the total gross floor area of the building or site, whichever is the lesser.

COMMERCIAL ACTIVITY (FOR THE PURPOSE OF THE CURTIS STREET BUSINESS AREA): means activities occurring within premises used or intended to be used primarily for selling, promoting, supporting or hiring services. This includes financial, research, office, administration, processing, manufacturing, industrial and other business activities. This definition does not include retail activities.

GROSS FLOOR AREA (FOR THE PURPOSE OF ANY RETAIL ACTIVITY) (FOR THE PURPOSE OF THE CURTIS STREET BUSINESS AREA): means the total cumulative gross floor area of a retail activity or integrated retail development. It does not include floor area occupied by car parking areas, loading and servicing facilities, shared pedestrian areas, toilet and building maintenance facilities, and areas not available for lease.

INTEGRATED RETAIL ACTIVITIES (FOR THE PURPOSE OF THE CURTIS STREET BUSINESS AREA): means an individual retail development, or a collection of any two or more retail activities that are developed and operate as a coherent entity (whether or not the activities are located on separate legal titles), and share one or more of the following:

- servicing and/or loading facilities;
- vehicle and/or pedestrian access;
- car parking;
- public spaces and/or facilities.

This definition includes shopping malls and large-format retail parks, but does not include trade supply retail, wholesale retail, yard-based retail or building improvement centres.

PLACES OF ASSEMBLY (FOR THE PURPOSE OF THE CURTIS STREET BUSINESS AREA): means any building or land used for public and/or private assembly or meeting of people and includes but is not limited to churches, halls, clubrooms, community centres, conference centres, chartered clubs and premises with a club licence and other similar establishments, including indoor and outdoor recreation facilities, such as gymnasiums, badminton and squash courts.

RETAIL ACTIVITY (FOR THE PURPOSE OF THE CURTIS STREET BUSINESS AREA) : means an activity displaying or offering services or goods for sale or hire to the trade or public and includes, but is not limited to: integrated retail activities, trade supply retail, yard based retail, supermarkets, service retail, and ancillary retail.

SENSITIVE ACTIVITIES AND USES: (USED IN THE HFSP ANALYSIS OF A HAZARDOUS FACILITY) means those activities and uses which are:

- schools, kindergarten or child care centres
- homes for the elderly, hospitals, residential care facilities, premises with high density, low mobility uses
- facilities critical to emergency response and utility lifelines
- transport corridors to emergency services

- residential activities (applies only in Central Area, Centres and Business Areas)

Sensitive activities and uses will require additional buffer zones from activities involving the use, storage, handling or disposal of hazardous substances.

SERVICE RETAIL (FOR THE PURPOSE OF THE CURTIS STREET BUSINESS AREA): means the sale of served food and/or beverages, and/or services such as, but not limited to video and DVD hire, dry cleaners, takeaway food outlets, cafés, pubs, bars, hairdressers and beauticians and banks.

SIGN (FOR THE PURPOSE OF THE CURTIS STREET BUSINESS AREA): means any name, figure, writing, image, character, outline, engraving, carving, spectacle, logo, display, delineation, announcement, notice, placard, poster, handbill, hoarding, billboard, aerial display, banner, advertising device or appliance, or any other things of a similar advertising nature, intended principally to attract the attention of the public and has implied or actual commercial advertising content, whether it is placed on or affixed to any land or building, or incorporated within the design of any building (whether by painting or otherwise) which is visible from a public space. This definition excludes:

- Signs within buildings and not visible from the outside
- Signs for the management of the legal road, public parks and reserves including official signs
- Advertising on vehicles, including trailers, except where the vehicle or trailer acts as a stationary support structure for commercial advertising
- Murals
- Sculptures

SUPERMARKET (FOR THE PURPOSE OF THE CURTIS STREET BUSINESS AREA): means a retail shop selling a wide range of foodstuffs, including fresh produce, meat, fish, dairy, alcoholic and other beverages, and packaged food for consumption off-site, as well as non-food grocery items and household goods. This definition includes discount stores, hypermarkets, department stores and warehouse club stores, where foodstuffs comprise more than 10% of the total gross floor area.

TRADE SUPPLY RETAIL (FOR THE PURPOSE OF THE CURTIS STREET BUSINESS AREA) : means a business engaged in sales to businesses, and may also include sales to the general public, and wholly consists of suppliers of goods in one or more of the following:

- automotive and marine supplies;
- building supplies;
- farming and agricultural supplies;
- garden and landscaping supplies;
- hire services (excluding hire of books, DVD and video);
- office furniture, equipment and systems supplies.

YARD BASED RETAIL (FOR THE PURPOSE OF THE CURTIS STREET BUSINESS AREA): means any retail activity which supplies goods or services primarily from an open or semi-covered yard, and where the yard comprises at least 50% of the total area used for retail activities. This includes but is not limited to: garden centres, service stations, automotive and marine supplies, agricultural supplies, heavy machinery and plant sales.

35. CURTIS STREET BUSINESS AREA

35.1 Introduction

The Curtis Street Business Area is located in Creswick Valley and is bounded by Old Karori Road to the west, Whitehead Road to the north and Curtis Street to the east. The area is 1.09 hectares in size and traversed by High Voltage Transmission lines.

The area was previously part of the adjoining Council landfill that has now become Ian Galloway Park. In the 1980s, Whitehead Road was constructed to provide better vehicular access to Karori and as a result the area was separated from Ian Galloway Park to form the triangular shaped site seen today. It was also at this time that Old Karori Road was closed on the site's western boundary.

From the 1930s until the 1990s the area was used as a Council depot. During that time the area was used to store, maintain and construct equipment relating to various council operations including drainage, streetworks and street cleaning. This included a range of buildings, including a number of sheds and an office. After the area ceased to be used as a depot it was cleared and sold into private ownership.

The area is highly modified from its original form, with ground levels having been raised by extensive fill and the associated culverting of the Kaiwharawhara Stream which runs beneath the area in a north-south alignment. The northernmost part of the area is level with Whitehead Road and Curtis Street, while the southern part is set at a lower ground level below Curtis Street. The topography rises steeply to the east and west of the area such that it forms a deep depression in the landscape.

This distinct landform is overlooked by individual dwellings located at various levels on the adjoining hillsides and partly screened by vegetation. The character of the wider area is influenced by the green residential setting and a steep, vegetated escarpment adjoining the western edge of the Curtis Street Business Area. These adjoining areas are zoned Outer Residential in the District Plan.

The Curtis Street Business Area provides for increased commercial activity in the western suburbs while at the same time reinforcing the District Plan's intentions of facilitating efficient use of land and compact urban development on a city-wide scale. The Curtis Street Business Area provides for a range of commercial, service and employment related uses within a planning framework that takes account of the specific characteristics of the local environment. Sensitive activities such as residential uses, schools and hospitals are discouraged due to the presence of overhead transmission lines.

The approach for the Curtis Street Business Area is to clearly signal, through the use of rules, those activities which are encouraged and those which are discouraged. Specifically this is achieved through an approach where activities are listed under different resource consent categories. Activities standards have also been imposed on all activities to ensure that the adverse effects of activities are avoided, remedied or mitigated, particularly with regard to effects on adjacent Residential Areas.

Issues of particular importance to the Curtis Street Business Area include urban design, retail distribution effects and traffic. Specific rules and environmental standards have been applied to ensure that these effects can be appropriately managed in terms of effects on landscape and residential character, Council's network of centres and the road network. Maintaining the character, appearance and environment in and around Business Areas is an important objective of the District Plan.

35.2 Curtis Street Business Area Objectives and Policies

35.2.1	To facilitate commercial activity in the Curtis Street Business Area to assist in meeting the social and economic needs of Wellington’s western suburbs and the wider City
---------------	---

- 35.2.1.1 Specifically provide for and encourage a range of commercial activities in the Curtis Street Business Area.
- 35.2.1.2 Encourage the co-ordinated, comprehensive development of the Curtis Street Business Area in accordance with a pre-approved concept plan.
- 35.2.1.3 Encourage a mixture of commercial tenancies to maximise the efficient use of the land and social and economic wellbeing.
- 35.2.1.4 Provide for temporary activities that contribute to the social, economic and cultural wellbeing of the community, whilst controlling any adverse effects in a manner that acknowledges their infrequent nature and limited duration.
- 35.2.1.5 Control the establishment of large integrated retail developments and large supermarkets.

Explanation to objective and policies

There is demonstrated demand for commercial and employment activity in Wellington’s western suburbs. The Curtis Street Business Area provides an opportunity for commercial activity to establish in an area ideally located to serve the suburbs of Northland, Karori and Wilton.

Given this opportunity, Council wishes for this to occur in a comprehensive and coordinated manner. A pre-approved concept plan which details site layout aimed at attracting and facilitating a range of commercial and employment activities is a key way of ensuring that land is developed efficiently, but also in a way that maximises the benefit to the wider community.

Restrictions have been imposed on the permitted amount of floorspace for integrated retail developments and supermarkets for the purpose of managing effects on the vitality and economic viability of Centres Areas identified in the District Plan.

Taking into account the provision of goods, services and commercial land in the western suburbs a mix of commercial activities is preferable to a single large entity establishing on the site. A mix of use would represent the most efficient use of the land and maximise social and economic wellbeing. Temporary activities are also encouraged in the Curtis Street Business Area, and these can include community events and cultural festivals. These activities make an important contribution to the social, economic and cultural wellbeing of Wellington’s communities. Within specified environmental limits greater flexibility is provided to temporary activities in recognition of their infrequent nature and limited duration.

35.2.2	To promote the creation of a high quality urban environment in the Curtis Street Business Area
---------------	---

- 35.2.2.1 Promote co-ordinated, comprehensive development of the Curtis Street Business Area.
- 35.2.2.2 Encourage the use of a pre-approved concept plan that details the co-ordinated and efficient layout and location of buildings; vehicle access ways; servicing areas and landscaping across the whole Curtis Street Business Area.

- 35.2.2.3 Promote an overall high standard of urban design and specifically encourage the development of sensitively designed and articulated buildings (including facades and roofscapes).
- 35.2.2.4 Ensure that all spaces accessed by the public are safe and designed to minimise opportunities for crime.
- 35.2.2.5 Ensure that signs contribute positively to the visual amenity of Curtis Street Business Area by:
- Maintaining and enhancing the architectural integrity and visual amenity of the host building or site.
 - Minimising visual clutter.

Explanation to objective and policies

The Curtis Street Business Area is a new business zoning in the city and is currently undeveloped. This provides an opportunity to facilitate the development of a high quality, comprehensively planned business area that can serve the needs of both business and the community efficiently.

Council encourages a pre-approved concept plan, to be assessed as a controlled activity, to provide a guiding spatial framework for the development of the area over time. Council will look favourably upon subsequent individual developments which are consistent with a pre-approved concept plan as this will demonstrate commitment to co-ordinated, comprehensive development of the area. However, concept plans are a voluntary mechanism, and if a concept plan is not sought or adhered to Council will use the resource consent process to help enable a co-ordinated development over time.

Council is also seeking to improve the quality of built development in the city through the imposition of controls on building design and sensitivity to the wider visual catchment. The benefits of high quality, comprehensively designed development include reduced amenity (mostly visual) impacts on adjacent properties, more efficient clustering of activities, and a more viable grouping of commercial activity over time.

35.2.3	To recognise the residential character, landscape and ecological values of Creswick Valley
---------------	---

- 35.2.3.1 Design buildings, structures and spaces in the Curtis Street Business Area to respect the integrity of the wider landscape and residential setting.
- 35.2.3.2 Discourage the use of reflective and brightly coloured building materials and cladding.
- 35.2.3.3 Encourage the retention of trees and vegetation along the western edge of the area adjacent to Old Karori Road.
- 35.2.3.4 Where existing vegetation cannot be retained, use type, species and patterns of replacement planting that are characteristic of the locality.
- 35.2.3.5 Ensure that earthworks and associated structures are designed and landscaped to reduce and soften their visual impact having regard to the character and visual amenity of the local area.
- 35.2.3.6 Ensure earthworks are managed to minimise the adverse effects of runoff on the ecological values of Kaiwharawhara Stream.
- 35.2.3.7 Encourage the use of permeable surfaces to enhance visual amenity and reduce incidences of sudden, large volume discharges to the Kaiwharawhara Stream

Explanation to objective and policies

The Curtis Street Business Area is located in a setting with established residential character, landscape and ecological qualities. Commercial development and activity in the area is encouraged within environmental limits which respect these values. The particular values are:

- *Residential areas set within extensive areas of vegetation.*
- *A well defined landscape setting within Creswick Valley with a strong green escarpment adjoining the western edge of the area.*
- *Indigenous flora and birdlife associated with the western escarpment (beyond the western boundary of the Curtis Street Business Area).*
- *In stream values of the Kaiwharawhara Stream.*

35.2.4 To protect the amenity of adjacent residential areas from activity and development in the Curtis Street Business Area

- 35.2.4.1 Control the height, bulk and location of buildings and developments for the purpose of managing shading, daylight, privacy, scale and dominance effects on adjacent residential areas.
- 35.2.4.2 Ensure that the visual effects of signage do not adversely affect the amenities of nearby residential areas.
- 35.2.4.3 Ensure that activities creating effects of noise, lighting, dust and the discharge of any contaminants are managed to avoid, remedy or mitigate adverse effects on nearby residential areas.
- 35.2.4.4 Ensure that the traffic generated by development and activity does not impose significant adverse effects on local residential streets.
- 35.2.4.5 Manage the scale, intensity and placement of signs to a form and scale appropriate to the amenity of nearby residential areas.

Explanation to objective and policies

The Curtis Street Business Area is set within a residential setting with the immediately adjacent land to the east and west zoned Outer Residential in the District Plan. It is important that the effects of commercial activities and buildings encouraged in the Curtis Street Business Area do not compromise the amenity of established residential areas. Particular amenity effects include the potential impact of large scale buildings (e.g. visual and privacy effects), noise, lighting, dust, the visual effects of signage, and traffic impacts on residential streets.

Given the proximity of the Curtis Street Business Area to established residential areas the approach to public and limited notification is particularly important. The rules and standards chapter adopts a different approach to notification than other business area chapters in the District Plan. In particular the Curtis Street Business Area includes a lesser number of “non-notification / service” provisions. This is a deliberate approach which reflects the 2009 amendments to the Resource Management Act 1991, which created a presumption towards non-notification. In addition it is considered generally appropriate that Council, when making notification decisions, exercise full discretion under Sections 95-95F of the Resource Management Act 1991. Notwithstanding, it is specifically noted that the relative absence of non-notification / service provisions, does not create a presumption towards notification.

35.2.5	To maintain the efficiency, convenience and safety of the surrounding road network and provide for safe and efficient movement within the Curtis Street Business Area
---------------	--

- 35.2.5.1 Control the type and scale of retail activity which establishes in the Curtis Street Business Area to manage the generation of traffic and associated impacts on the road network.
- 35.2.5.2 Ensure that the location and design of developments that cater for activities that generate significant levels of traffic or increase demand for parking are accessible by multiple transport modes and do not result in:
- A significant increase in traffic that would be incompatible with the capacity of adjoining roads and their function in the road hierarchy, or would lead to unacceptable congestion.
 - An on-street parking demand that extends into Residential Areas and/or leads to unsatisfactory parking arrangements.
 - The creation of an unacceptable road safety risk.
- 35.2.5.3 Design the layout of parking areas so that on-site circulation space is safe, convenient and easily understood by motorists and pedestrians.
- 35.2.5.4 Encourage buildings and spaces to have a high level of accessibility, particularly for people with restricted mobility.
- 35.2.5.5 Require the provision of appropriate servicing and site access for activities in the Curtis Street Business Area.
- 35.2.5.6 Manage the scale, intensity and placement of signs to a form and scale appropriate to viewer distance and viewing speed.

Explanation to objective and policies

Development and activity in the Curtis Street Business Area will generate additional vehicle traffic on the surrounding road network. Whilst recognising that the primary purpose of the road network is to facilitate the movement of people and goods for the social and economic benefit of the city, it is important that the adverse effects of traffic are managed to maximise convenience, access and safety. These principles shall apply to:

- *The impact of development and activity on the external road network including on-street parking demand.*
- *The interface of the Curtis Street Business Area with the external road network.*
- *The management of servicing, vehicle circulation and parking within the Curtis Street Business Area.*

In managing these issues Council will seek to influence the type and scale of activities within the Curtis Street Business Area (particularly retail activities); the configuration and relationship of buildings, access routes and parking areas; and the location and scale of signage for the purpose of minimising driver distraction.

It is expected that the majority of visitors to the Curtis Street Business Area will arrive by private vehicle, but access by alternative transport modes is encouraged. Providing for access by a range of transport modes will maximise the ongoing viability and attraction of the area. Providing for access by pedestrians and cyclists is important, and designing developments to allow for future access by public transport modes (buses) is encouraged.

35.2.6	Manage reverse sensitivity effects associated with the development and use of the Curtis Street Business Area
---------------	--

- 35.2.6.1 Ensure that activities that create adverse noise, lighting, dust and the discharge effects of any contaminants are managed to avoid adverse effects on other activities within the Curtis Street Business Area.
- 35.2.6.2 Discourage sensitive activities from establishing in the Curtis Street Business Area to avoid conflicts with the commercial activities encouraged for the area and only allow these to establish where reverse sensitivity effects can be properly avoided, remedied or mitigated.
- 35.2.6.3 Ensure activities, development and vegetation planting in the Curtis Street Business Area does not compromise the operation, maintenance and upgrading of the high voltage transmission lines traversing the area.

Explanation to objective and policies

There is a range of actual and potential reverse sensitivity effects that relate to the Curtis Street Business Area. This includes the impact of activities and development on the high voltage overhead transmission lines and potential conflicts between activities within the area. Specific considerations include:

- *Protecting the ongoing operation and maintenance of the high voltage overhead transmission lines owned by Transpower New Zealand Ltd.*
- *Acknowledging the primacy of commercial uses within the Curtis Street Business Area and protecting these from the threat posed by sensitive activities not promoted for the area.*

35.2.7	To facilitate subdivision which assists the development of the area for commercial use
---------------	---

- 35.2.7.1 Support subdivision which facilitates the development and use of the Curtis Street Business Area for its intended commercial purpose.
- 35.2.7.2 Ensure that subdivision in the Curtis Street Business Area does not compromise the ability for the area as a whole to be developed in a co-ordinated, comprehensive manner.
- 35.2.7.3 Support subdivision which is consistent with any concept plan which has already been approved under Rule 36.2(c).
- 35.2.7.4 Ensure the sound design, development, and appropriate servicing of all subdivisions.

Explanation to objective and policies

Subdivision is important in providing the certainty of tenure that encourages new operators and tenants to occupy and develop land. However, it is important that subdivision occurs in such a way that the comprehensive development outcomes promoted for the area (see policy 35.2.2.1) are not compromised by inefficient fragmentation of land or configuration of lots. Council will look favourably upon subdivision which is consistent with any concept plan already approved for the Curtis Street Business Area, as this will demonstrate commitment to co-ordinated, comprehensive development of the area.

35.2.8 To facilitate and enable the exercise of tino rangatiratanga and kaitiakitanga by Wellington’s tangata whenua and other Maori

- 35.2.8.1 In considering resource consents, Council will take into account the principles of tino rangatiratanga, kaitiakitanga and of the Te Tiriti o Waitangi / the Treaty of Waitangi.

Explanation to objective and policies

Maori concepts present a different view for the management of the City’s natural and physical resources. In particular, kaitiakitanga is a specific concept of resource management. By acknowledging ancestral relationships with the land and natural world, a basis can be constructed for addressing modern forms of cultural activities.

The principles that underlie the Treaty provide a basis for the management of natural and physical resources. The principles include having regard to consultation, partnership and a shared responsibility for decision making. For this reason specific rules have been included in the District Plan requiring consultation in specific situations. The environmental result will be that appropriate developments give effect to Maori cultural values.

35.2.9 To encourage energy efficiency and environmentally sustainable building design

- 35.2.9.1 Promote a sustainable built environment in the Curtis Street Business Area involving the efficient end use of energy and other natural and physical resources and the use of renewable energy, especially in the design and use of new buildings and structures.
- 35.2.9.2 Ensure all new buildings provide appropriate levels of natural light to occupied spaces within the building.

Explanation to objective and policies

New building works are users of natural and physical resources, and can have adverse effects on the environment, for example, through high rates of water use or electricity consumption. Sustainable building design features and use of sustainable building methods are encouraged as a means of minimising adverse environmental effects. Developments that incorporate environmentally sustainable design principles will be viewed as having a positive effect on the environment.

35.2.10 To prevent or mitigate any adverse effects of the use, disposal or transportation of hazardous substances including waste disposal

- 35.2.10.1 Ensure the environment is safeguarded by managing the storage, use, handling and disposal of hazardous substances.
- 35.2.10.2 Control the use of land for end point disposal of waste to ensure the safe disposal of solid and hazardous waste to acceptable standards.
- 35.2.10.3 Reduce the potential adverse effects of transporting hazardous substances.
- 35.2.10.4 Ensure that development and activity appropriately avoids, remedies or mitigates the adverse effects of contaminated soil on human and environmental health.

Explanation to objective and policies

Council is concerned that the community and environment should not be exposed to unnecessary risk from hazardous substances. The District Plan aims to control the use of land to prevent or mitigate the adverse effects of hazardous substances by considering the

appropriateness of the site location and other site requirements to minimise the risk of accidental release. Although these area only two facets of hazardous substances management, others are outside of the scope of the Act and the District Plan.

An issue specific to the Curtis Street Business Area is the presence of contaminated soil associated with historical uses including unauthorised fill and the former use of the area as a Council depot. It is important that the development and use of the area is appropriately managed for human health and environmental reasons.

35.3 Methods

To achieve the outcomes specified in the objectives and policies above Council will use the following methods:

- Application of rules, environmental standards and assessment criteria set out in Chapter 36 of the District Plan (Curtis Street Business Area rules and standards) and other parts of the District Plan as relevant.
- Direct consideration of the objectives and policies in the assessment of resource consent applications.
- Consideration of higher level Council strategies and policies during the assessment of resource consent applications (this includes the Urban Development Strategy 2006 and the Centres Policy 2008).
- Consideration of external documents including the Wellington Regional Strategy and higher order documents prepared under the Act including national policy statements and the Wellington Regional Policy Statement.
- Council infrastructure and transport delivery projects (as appropriate).
- Council plans and strategies prepared under other legislation (including Annual Plans and Long Term Plans).
- Advocacy.

Chapter 36. Curtis Street Business Area Rules and Standards

Guide to Rules

Note: The following table is intended as a guide only. Please refer to the rules for detailed requirements.

P refers to Permitted Activities, C to Controlled Activities, DR to Discretionary Activities (Restricted), DU to Discretionary Activities (Unrestricted) and NC to Non-Complying Activities

Activities	Rule	P	C	DR	DU	NC
The construction of, alteration of, or addition to, buildings and structures	36.1(a)	•				
Car parking	36.1(b)	•				
Commercial activities	36.1(c)	•				
Demolition of buildings and structures	36.1(d)	•				
Retail activities	36.1(e)	•				
Signs	36.1(f)	•				
Temporary activities	36.1(g)	•				
Earthworks	36.1(h)	•				
Vegetation removal	36.1(i)	•				
Subdivision	36.2(a)		•			
Hazardous substance activities	36.2(b)		•			
Concept plans	36.2(c)		•			
Permitted and controlled activities not meeting standards	36.3(a)			•		
Retail activities exceeding 500m ² gross floor area	36.3(b)			•		
Commercial activities exceeding 2500m ² gross floor area	36.3(c)			•		
Integrated retail activities exceeding 2500m ² gross floor area	36.3(d)			•		
Supermarkets exceeding 1500m ² gross floor area	36.3(e)			•		
Places of assembly	36.4(a)				•	
Sensitive activities and uses	36.4(b)				•	
Activities not provided for as permitted, controlled, restricted discretionary and discretionary activities	36.5(a)					•

36. CURTIS STREET BUSINESS AREA RULES AND STANDARDS

36.1 PERMITTED ACTIVITIES

Unless otherwise provided for in Sections 36.2 – 36.5 the following activities are permitted activities subject to meeting the activities standards set out in Section 36.6:

- (a). The construction of, alteration of, or addition to, buildings and structures
- (b). Car parking
- (c). Commercial activities
- (d). Demolition of buildings and structures
- (e). Retail activities
- (f). Signs
- (g). Temporary activities
- (h). Earthworks
- (i). Vegetation removal

36.2 CONTROLLED ACTIVITIES

The following activities are controlled activities subject to meeting the activities standards set out in Section 36.6:

(a). Subdivision

Control: In assessing subdivision under Rule 36.2(a) Council's control will be limited to stormwater, sewerage and water supply servicing; provision of legal and practical physical access to every unit or lot; the allocation of accessory units to principal units; the allocation of covenant areas to lease areas to ensure compliance with servicing rules; and subdivision layout.

(b). Hazardous substance activities

Control: In assessing hazardous substance activities under Rule 36.2(b) Council's control will be limited to the use, storage or handling of hazardous substances.

(c). Concept plans

Control: In assessing concept plans under Rule 36.2(c) Council's control will be limited to the layout of buildings, car parking areas, vehicle access ways and servicing areas and any landscaping areas proposed. Concept plans will also be assessed at a broad level for their ability to provide for development which complies with activities standards in Section 36.6.

Notification / service: Concept plans assessed as Controlled Activities under Rule 36.2(c) will not be publicly notified or limited notified.

36.3 RESTRICTED DISCRETIONARY ACTIVITIES

The following activities are restricted discretionary activities:

(a). Activities listed as permitted or controlled activities but do not meet the activities standards set out in Section 36.6

Discretion: In assessing applications under this rule Council's discretion will be restricted to the issue specified in the standard not met.

Notification / service:

- Activities assessed as Restricted Discretionary Activities under Rule 36.3(a) will not be publicly notified (unless special circumstances exist) or limited notified in respect of

infringements to activities standards 36.6(g) (dust); 36.6(i) (electromagnetic radiation); 36.6(j) (screening of activities and storage) or 36.6(l) vehicle parking, servicing and site access.

- Transpower New Zealand Ltd may be considered to be an affected party to an application for the construction of, or addition to, buildings and structures in respect of infringements to the building height and footprint standards in Section 36.6(a).

(b). Retail activities exceeding 500m² gross floor area

Discretion: In assessing applications under this rule Council's discretion will be restricted to traffic generation, circulation and safety; provision of car parking and servicing areas; and pedestrian access and safety. Where applications made under this rule also include infringements to other activities standards set out in Section 36.6 Council's discretion will be extended to the standard(s) not met.

(c). Commercial activities exceeding 2500m² gross floor area

Discretion: In assessing applications under this rule Council's discretion will be restricted to traffic generation, circulation and safety; provision of car parking and servicing areas; and pedestrian access and safety. Where applications made under this rule also include infringements to other activities standards set out in Section 36.6 Council's discretion will be extended to the standard(s) not met.

(d). Integrated retail activities exceeding 2500m² gross floor area

Discretion: In assessing applications under this rule Council's discretion will be restricted to potential impacts on the vitality and economic viability of Centres Areas identified in the District Plan. Where applications made under this rule also include infringements to other activities standards set out in Section 36.6 Council's discretion will be extended to the standard(s) not met.

(e). Supermarkets exceeding 1500m² gross floor area

Discretion: In assessing applications under this rule Council's discretion will be restricted to potential impacts on the vitality and economic viability of Centres Areas identified in the District Plan. Where applications made under this rule also include infringements to other activities standards set out in Section 36.6 Council's discretion will be extended to the standard(s) not met.

36.4 DISCRETIONARY ACTIVITIES

- (a). Places of assembly
- (b). Sensitive activities and uses

36.5 NON-COMPLYING ACTIVITIES

- (a). Activities not provided for as permitted, controlled, restricted discretionary or discretionary activities

EXPLANATORY NOTES FOR RULES

Notification / service:

Except as provided for under Rule 36.3(a), decisions on public and limited notification in the Curtis Street Business Area will be made without limitation pursuant to Sections 95-95F of the Resource Management Act 1991.

Retail and commercial activities assessed under Rules 36.3(b) and 36.3(c)

These rules apply to retail and commercial activity across the whole Curtis Street Business Area and not on a site by site basis. Activities exceeding the floorspace thresholds specified above (500m² gross floor area for retail activities and 2,500m² gross floor area for non-retail commercial activities) or creating a greater degree of non-compliance with these standards for the area as a whole will require resource consent and a full transportation assessment.

Commercial activities assessed under Rule 36.3(c)

As provided for in the definition of commercial activity for the Curtis Street Business Area this rule does not apply to retail activity.

Purpose of concept plan

Council encourages the development and approval of a concept plan for the Curtis Street Business Area in order to promote comprehensive development of the area. The benefit of an approved concept plan is that it will provide a spatial framework for assessing applications for subdivision or individual buildings. The following key points are made about concept plans sought under Rule 36.2(c):

- Application for approval of a concept plan is voluntary.
- They are expected to show the intended pattern of development at a broad level only, with building footprints, vehicle parking, servicing and site access elements required to be shown indicatively
- The assessment of concept plans will not be linked to any associated resource consent requirements (they will be assessed in isolation) except that building footprints must not exceed 500m² gross floor area and compliance with the vehicle parking, servicing and site access standards must be achievable within the indicative layout shown. Where compliance with these standards, specified in Section 36.6(a), cannot be demonstrated, concept plans will be assessed as Restricted Discretionary Activities under Rule 36.3(a).
- Approval of a concept plan does not waive other resource consent requirements specified in Section 36 for the Curtis Street Business Area but subdivision and buildings which are consistent with a pre-approved concept plan will be viewed favourably by Council.

Concept plan information requirements

Concept plans submitted under Rule 36.2(c) are required to show the indicative footprints and layout of buildings, car parking areas, vehicle access ways and servicing areas across the whole Curtis Street Business Area. A plan of a scale 1:500 or greater must be submitted along with a design statement describing the rationale for the overall layout of these elements. For the purposes of clarification, drawings of individual buildings will not be required.

Assessment Criteria

Assessment criteria are set out in Section 36.7 to provide guidance in the assessment of resource consent applications for the Curtis Street Business Area. However, it is specifically noted that the assessment criteria are not intended to limit Council's discretion when assessing restricted discretionary, discretionary or non-complying activities. In the case of restricted discretionary activities the scope of Council's discretion is specified in the rules, and the discretion is expressed in deliberately broad terms (e.g. "landscaping", "urban design").

36.6 ACTIVITIES STANDARDS

(a). Concept plans

- i. Building footprints shown on concept plans must not exceed 500m² gross floor area.
- ii. The development pattern shown in the concept plan must not preclude the ability to comply with the vehicle parking, servicing and site access standards set out in Section 36.6(m).

(b). Building height and footprint (design of buildings and structures)

- i. The maximum height of any new building, alteration, addition or structure in the Curtis Street Business Area is 114m above mean sea level or 6m above ground level, whichever is the higher.
- ii. The maximum footprint of any new building, alteration, addition or structure in the Curtis Street Business Area is 500m² gross floor area.

(c). Signs

- i. Any sign visible from legal road or residential areas must not flash or contain moving images, text or lights.
- ii. There must be no more than two signs per building.
- iii. Signs attached to buildings:

- Must not be more than 5m² in area.
- Must not obstruct the safe and convenient passage of pedestrians and for signage attached to the underside of verandahs clearance of 2.5m above ground level must be maintained.
- Must not obscure windows or architectural features.
- Must not project above parapet level (or the highest part of the building to which it is attached).
- Must not project above the level of any verandah or shopfront fascia.

iv. Freestanding signs:

- Must not be more than 6m² in area.
- Must not be more than 6m in height.
- There must not be more than one freestanding sign per road frontage on Curtis Street and Whitehead Road.
- There must be no freestanding signs on the Old Karori Road frontage.

v. No sign shall be for the purpose of third party advertising.

(d). Temporary signs

Temporary signs may be established for the purposes of advertising a community event subject to the following:

- i. The signs must not be erected for more than 28 consecutive days.
- ii. The signs must be fully removed within 7 days of the completion of the community event.
- iii. The signs must comply with the standards for signs in 36.6(c) above except that standards specifying the maximum area and number of signs per site frontage may be exceeded.

(e). Earthworks and retaining walls

i. Earthworks shall not:

- Exceed a maximum height of cut or fill of 1.5m
- Exceed a slope of cut or fill of 34 degrees
- Be closer to the site boundary than the height of the cut or fill
- Exceed an area to be cut or filled of 250m²
- Involve the transport of material greater than 200m³ to and from the site

ii. Retaining walls shall not:

- Exceed a maximum height of cut or fill of 1.5m
- Involve earthworks that are not retained by a consented building or structure
- Exceed an area to be cut or filled of 250m²

- iii. Resource consent applications for earthworks must be accompanied by the following:
- An earthworks plan showing proposed cut and fill areas
 - Any erosion and sediment control measures consistent with the principles and measures in Greater Wellington Regional Councils 'Erosion and Sediment Control guidelines for the Wellington Region (2003)' or 'Erosion and Sediment Control for small sites (2006)'
 - Details of any cut faces or constructed slope faces e.g. retaining structures, including materials and/or landscaping and vegetation replacement details. No cut face should be visible above any building roofline. Constructed slopes should be planted or grassed.
 - Identification of any relevant geotechnical issues associated with erosion, falling debris, subsidence, slippage or inundation from any earthworks and related structures or building platforms. A full geotechnical report may be required from an appropriately qualified and experienced person.
 - An accompanying assessment of effects detailing the full effects of the works including visual effects, erosion and sedimentation effects, effects on adjacent watercourses (if and where relevant), related geotechnical effects (if and where relevant) and mitigation measures to address the effects.
 - A transportation assessment for the moving of fill on or off site.

(f). Landscaping and screening

- i. At least 5% of car parking areas not contained within buildings and greater than 700m² or containing more than 35 car parks must be landscaped or planted with trees.
- ii. Areas within the car parking area and areas adjoining or fronting roads must be landscaped.
- iii. Any earthworks and/or retaining structures within 10m of the western site boundary and involving vegetation removal must include vegetative planting and landscaping.

(g). Lighting

- i. Any activity which requires outdoor areas to be lit shall ensure that direct or indirect illumination does not exceed 8 lux at any point on land zoned for residential or open space purposes (including road reserve)..
- ii. Subject to standard 36.6(f)(i) any development which includes roads and outdoor public spaces available for use during hours of darkness shall be designed and installed in accordance with AS / NZS 1158.3.1:2005 and amendments.

(h). Dust

- i. Activities must not create a dust nuisance. A dust nuisance has occurred if:

- There is visible evidence of suspended solids in the air beyond the site boundary.
- There is visible evidence of suspended solids traceable from a dust source settling on the ground, building or structure on a neighbouring site, or water.

With regard to the above provisions, where sites are contiguous and are held under the same ownership then any dust nuisance shall be measured at the periphery of the land holding within the District Plan area.

(i). Discharge of Contaminants

The discharge of contaminants to air, land or water is a Regional Council responsibility and activities causing discharges may require resource consent from the Regional Council. However, attention is drawn to the general duty of all persons under Section 17 of the Act to avoid, remedy or mitigate adverse effects on the environment.

(j). Electromagnetic radiation

- i. Activities must be conducted to comply with the New Zealand Standard NZS 277.1:1999 (Radio Frequency fields) and any subsequent amendment.

(k). Screening of Activities and Storage

- i. Any exterior storage area, including waste storage area, must be screened so that it is not visible from any Residential Area or public space.

(l). Subdivision

- i. Every building or structure adjoining a new boundary must comply fully with the standards for building and structures specified in Section 36.6(a) or otherwise be lawfully established.
- ii. Every allotment must have services in compliance with City Bylaws, or, if applicable, the Council's Code of Practice for Land Development.
- iii. Every allotment must have practical, physical and legal access to a formed legal road.
- iv. Every allotment must have drive on vehicle access and parking constructed in accordance with the standards in Section 36.6(l).
- v. All earthworks needed to complete the subdivision are undertaken.
- vi. For any subdivision incorporating new roads, all services must be reticulated underground.
- vii. Resource consent applications for subdivision must be accompanied by the following:
 - Information sufficient to allow Council to assess compliance with the activities standards in Section 36.6((m) for vehicle parking, servicing and site access.
 - A certificate stating that all existing services have been located so that they are all contained entirely within the boundaries of the site being serviced or within such right of way or easement

relating to the site, and are in accordance with the City Bylaws, and, if applicable, the Council's Code of Practice for Land Development.

- Current copies of titles for all affected properties.
- Accurately drawn plans at a scale of 1:500 or at a larger scale as appropriate and copies or reduced copies submitted to be of A4 or A3 size.
- A certificate stating the land is not likely to be subject to material damage by erosion, subsidence, slippage or inundation from any source.
- All certificates, plans and information supplied must be signed by a licensed cadastral surveyor or other suitably qualified person for the purposing of certifying accuracy.

(m). Vehicle Parking, Servicing and Site Access

Vehicle parking

- i. All required parking shall be provided within the Curtis Street Business Area.
- ii. All parking shall be provided and maintained in accordance with sections 1, 2 and 5 of the joint Australian and New Zealand Standard 2890.1 - 2004, Parking Facilities, Part 1: Off-Street Car Parking.
- iii. Where carparking is located within a building, a minimum height clearance of no less than 2.2 metres is required.
- iv. The gradient for carparking circulation routes shall not be more than 1 in 8.

Servicing

- v. All required servicing shall be provided for within the Curtis Street Business Area.
- vi. On each site in the Curtis Street Business Area, at least one loading area shall be provided as follows:
 - Where loading areas are located within a building, a minimum height clearance of 4.25 metres is required.
 - For buildings serviced by lifts, all levels shall have access to a loading area by way of a lift.
 - The loading area shall be located no further than 15 metres from a lift and there shall be level access between them.
 - Turning paths shall be based on the standard for a medium rigid truck as illustrated below:

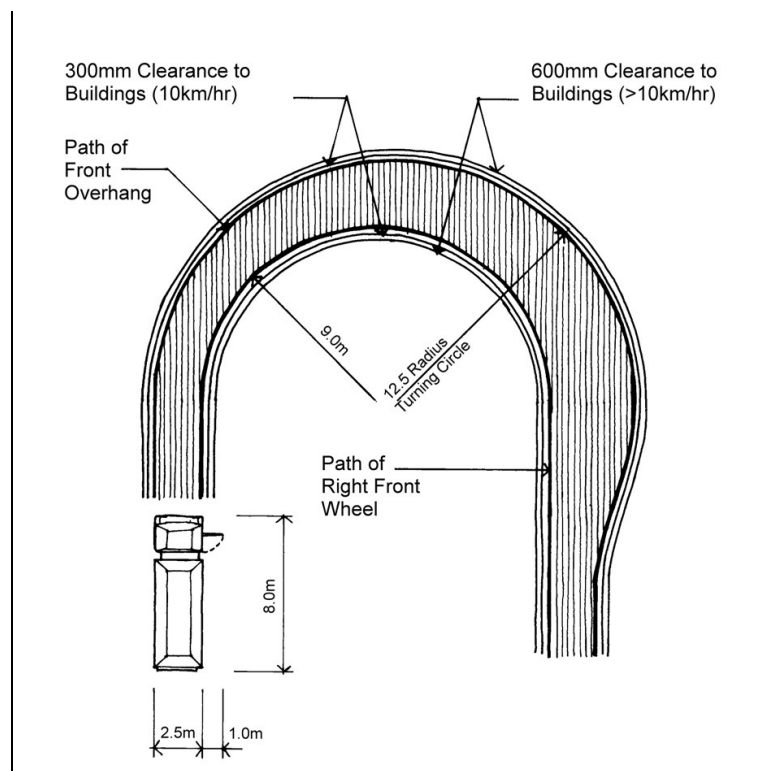

- vii. For loading areas located outdoors, the minimum width shall be 3 metres and the minimum length 9 metres.
- viii. For loading areas located within a building, the minimum width shall be 4 metres and the minimum length 9 metres.

Site access for vehicles

- ix. Site access shall be provided and maintained in accordance with section 3 of the joint Australian and New Zealand Standard 2890.1 – 2004, Parking Facilities, Part 1: Off-Street Car Parking (or its successor).
- x. Subject to standard 36.6(m)(ix) no vehicular access shall be situated closer to an intersection than the following:
 - Arterial and principal streets 20m
 - Collector streets 15m
 - Other streets 10m
- xi. There shall be a maximum of one vehicle access to any site except that sites with more than one frontage may have one access across each frontage.
- xii. The width of any vehicle crossing to a site shall not exceed 6 metres.
- xiii. Where vehicular access can be provided from a service lane or right-of-way registered in favour of the site or other private road or private right-of-way, no vehicle access shall be from a street.
- xiv. All access to sites must be designed to permit a free flow of traffic so that vehicles do not queue on the street.

(n). Noise

- i. Noise emission levels from activities in the Curtis Street Business Area when measured at or within the boundary of any site or at the outside wall of any building on any site other than the site from which the noise is emitted in the Curtis Street Business Area shall not exceed the following limits:
 - At all times 60dB L_{Aeq} (15 min)
 - At all times 85dB L_{AFmax}
- ii. Where it is impractical to measure outside the building, measurements shall be made inside (with windows closed). Where indoor measurements are made, then the noise limits stated above shall be reduced by 15dB.
- iii. Noise emission levels from activities in Curtis Street Business Areas when measured at or within the boundary of any residential site shall not exceed the following limits:

• Monday to Sunday	7am to 7pm	50dB L_{Aeq} (15 min)
• Monday to Sunday	7pm to 10pm	45dB L_{Aeq} (15 min)
• Monday to Sunday	10pm to 7am	40dB L_{Aeq} (15 min)
• Monday to Sunday	10pm to 7am	65dB L_{AFmax}

Fixed Plant Noise

- iv. Noise emission levels in the Curtis Street Business Area from fixed plant when measured at or within the boundary of any site, or at the outside wall of any building on any site, other than the building or site from which the noise is emitted shall not exceed the following limits:
 - At all times 55dB L_{Aeq} (15 min)
 - Monday to Sunday 10pm to 7am 80dB L_{AFmax}
- v. Noise emission levels from fixed plant in Curtis Street Business Area must comply with standard 36.6(n)(iii).
- vi. The noise limits set in standard 36.6(n)(iv) shall not apply to fixed plant that is used solely for emergency purposes. Examples of such equipment are standby generator sets that are used to supply electricity only at times of electrical supply failure, or for plant used only during life threatening situations such as smoke fans or sprinkler pumps. This fixed plant is exempt from the noise limits provided that it:
 - only operates for maintenance between 8am and 5pm weekdays, and
 - can comply with standard 36.6(n)(i), or
 - is an electricity generator sets that can only be used on an emergency basis and is not used to generate power for the national grid.

(o). Use, Storage and Handling of Hazardous Substances

- i. For those activities which are not specifically exempted (see Section 3.5.2.2) the cumulative effect ratio calculated using the HFSP will be

used to determine whether or not those other activities should be Permitted Activities according to the table below.

Location	Hazard Area	Not Hazard Area	Not Hazard Area
Effect ratio	0.002 < ER ≤ 0.05	0.002 <ER ≤ 0.1	≤ 0.02
Conditions applying	7.6.2.3.2 to 7.6.2.3.12	7.6.2.3.2 to 7.6.2.3.12	7.6.2.3.9, 7.6.2.3.11 and 7.6.2.3.12 only

- ii. Except for the storage, use or handling of Liquid Petroleum Gas (LPG), any area where hazardous substances are used, stored or handled in any manner on-site shall have secondary containment (via bunding or otherwise) using materials that are resistant to the hazardous substances handled on-site. Secondary containment systems also need to comply with any relevant provisions under the Hazardous Substances and New Organisms Act 1996.
- iii. Except for the storage, use or handling of Liquid Petroleum Gas (LPG), any secondary containment system shall be maintained to ensure that it will perform the functions for which it was designed and contain any spill or accidental release.
- iv. Except for the storage, use or handling of Liquid Petroleum Gas (LPG), any area(s) where hazardous substances are loaded, unloaded, packaged, mixed, manufactured or otherwise handled shall have a spill containment system [that is compliant with relevant provisions under the Hazardous Substances and New Organisms Act 1996.
- v. Except for the storage, use or handling of Liquid Petroleum Gas (LPG) secondary containment systems shall be designed to contain any spill or accidental release of hazardous substance, and any storm water and/or fire water that has become contaminated, and prevent any contaminant from entering the sewerage or stormwater drainage system unless expressly permitted under a resource consent or trade waste permit.
- vi. All stormwater grates, collection structures and inspection chamber covers on the site shall be clearly marked as such.
- vii. Any area where vehicles, equipment or containers that are or may have been contaminated with hazardous substances are washed down shall be designed, constructed and managed to prevent the effluent from the washdown area from discharge into or onto land, entry or discharge into the sewerage or stormwater drainage system unless expressly permitted by a rule in a regional plan, trade waste permit or resource consent.

Hazardous Substances Signage

- viii. All facilities must display signage to indicate the nature of the hazardous substances present (compliance with the provisions of the Hazardous Substances and New Organisms Act 1996 and the requirements of the Building Code (F8) or the Code of Practice “Signage for Premises Storing Hazardous Substances and Dangerous

Goods” of the New Zealand Chemical Industry Council (Nov 2004) is a minimum requirement.

Waste management

- ix. Any process waste or waste containing hazardous substances shall be stored in a manner which complies with 36.6(o)(i) - (vii) above
- x. Any hazardous facility generating wastes containing hazardous substances shall dispose of these wastes to facilities which, or waste disposal contractors who meet all the requirements of regional and district rules for discharges to the environment, and also the provisions of the Hazardous Substances and New Organisms Act 1996.

Other

- xi. Council must be informed of the activity’s location, the nature of the activity and when the activity commences and ceases.

General notes

- The on-site disposal of hazardous substances will be controlled through Council’s Waste Management Strategy, through obtaining the appropriate discharge consents from the Regional Council or trade waste permits, and through relevant controls on disposal of hazardous substances by the Hazardous Substances and New Organisms Act 1996.
- In addition to the provisions of the Plan, all activities which involve the use, storage, handling or transportation of hazardous substances are regulated for on-site and off-site effects by a range of other legislation and regulations, and associated standards and codes of practice which should be complied with. Key pieces of legislation include:
 - The Hazardous Substance and New Organisms Act 1996
 - Legislation, rules and standards relating to the transportation of hazardous substances (Land Transport Act 1993, Land Transport Rule: Dangerous Goods 1999 and New Zealand Standard 5433:1999)
 - The Building Act 1991
 - The Health Act 1956
 - The Fire Service Act 1975
 - The Health and Safety in Employment Act 1992
 - The Radiation Protection Act 1965
 - The Agricultural Compounds and Veterinary Medicines Act 1997

36.7 ASSESSMENT CRITERIA

(a). Concept plans sought under Rule 36.2(c)

Concept plans assessed under Rule 36.2(c) will be considered in terms of whether they:

- Promote a co-ordinated and efficient layout of car parking areas; vehicle access ways; servicing areas; and landscaping areas across the whole Curtis Street Business Area.
- Promote the creation of a high quality business environment which can provide a range of goods and services to the western suburbs and wider city catchment.

(b). Site layout, design and external appearance of buildings and structures

The proposal:

- Is consistent with a concept plan already approved under Rule 36.2(c)

Or, the proposal:

- Acknowledges the residential and landscape character of the Creswick Valley local environment.
- Incorporates design features which modulate the building(s) and minimise actual and perceived blank walls and excessive building mass.
- Uses materials and colours that minimise reflectivity and brightness.
- Incorporates design features which break up large roof planes and overall perceived mass of the roof, possibly using 'saw-tooth' and green roof designs.
- Locates buildings, structures and spaces to minimise visual impact and form an integrated solution.
- Orientates building frontages, windows and main public entrances towards Whitehead Road and Curtis Street.
- Locates publically accessible open spaces so they can be overlooked from within buildings in the Business Area.
- Enhances the sense of arrival to the area and includes appropriate shelter, canopies and transitional spaces.
- Is visually discrete and set generally below the level of Curtis Street.
- Provides for a good quality working environment.
- Promotes pedestrian safety and accessibility, including for people with restricted mobility.
- Incorporates design principles for increasing the level of natural surveillance and reducing crime.
- Arranges activities on the site and incorporates landscaping to reduce the adverse visual effects of car parking, access, servicing and storage areas.

(c). Signs

The proposal:

- Is not visually obtrusive to sites in residential areas or from any public space.
- Is in scale with the associated activity and / or building and compatible with the visual character of the area.
- Will not result in visual clutter;
- Is for illuminated signage that will not adversely affect visual and / or residential amenity.
- Is for signage that will not compromise pedestrian or traffic safety.

(d). Earthworks, landscaping and screening

The proposal:

- Includes earthworks which have been designed by a suitably qualified and experienced person, for example, a chartered engineer practising in the field of civil / geotechnical engineering.
- Includes earthworks which are designed in accordance with NZS4404:2004 Land Development and Subdivision Engineering and NZS4431: 1989 Code of Practice for Residential Earthworks.
- Includes methods to design and manage earthworks for the purpose of ensuring compliance with Greater Wellington Regional Council's Erosion and Sediment Control Guidelines for the Wellington Region.
- Includes an earthworks and construction management plan defining acceptable standards for environmental and amenity protection and public safety during the construction process.
- Includes retaining and stabilising structures which will effectively support and stabilise earthworks.
- Specifies effective methods for controlling dust and sediment including potential impacts on watercourses
- Uses species and patterns of planting that are characteristic of the locality and enhance the development.
- Breaks up large areas of car parking into smaller spaces through the use of building location, landscape planting, surface treatment and pedestrian pathways.
- Uses retaining walls which are sensitively designed to integrate with the surrounding environment.
- Maximises the use of permeable materials and surfaces.

(e). Subdivision

The proposal:

- Is consistent with a concept plan already approved under Rule 36.2(c)

Or, the proposal:

- Is consistent with Section 106 of the Act.
- Complies with the relevant parts of the Subdivision Design Guide, City Bylaws and Council's Code of Practice for Land Development.

- Involves allotments which are capable of accommodating development that complies with the standards in the District Plan for activities and for buildings and structures.

The extent to which any subdivision on the site will:

- Impact on the ability of the transmission line owner to operate, maintain and upgrade the high voltage transmission network.
- Compromise the structural integrity of the transmission line.
- Create a risk of electrical hazards due to the mature height of any associated vegetation, including within any landscaped areas.
- Result in exposure to electromagnetic fields, and the degree to which these can be avoided, remedied or mitigated.
- Comply with the New Zealand Electrical Code of Practice for Electrical Safe Distances 34: 2001, the Electricity (Hazards from Trees) Regulations 2003, and Transpower's Corridor Management Policy.

Company lease, cross lease and unit title subdivision

The subdivision responds to:

- The need to ensure permanent site access and continued provision for on site loading and unloading facilities.
- The current and future allocation of subdivisional areas to achieve the efficient use of land and buildings.

(f). Traffic

The proposal:

- Will not result in a significant increase in traffic that would be incompatible with the capacity of adjoining roads and their function in the road hierarchy, or would lead to unacceptable congestion.
- Will not result in on-street parking demand that extends into residential areas and / or leads to unsatisfactory parking arrangements.
- Will not create an unacceptable road safety risk.

(g). Vehicle parking, loading and site access

The proposal:

- Is consistent with a concept plan already approved under Rule 36.2(c)

Or, the proposal:

- Will not generate demand sufficient to justify compliance with on-site parking requirements.
- Provides on-site parking that does not detract from the visual appearance of the property or townscape character.
- Has a suitable alternative for on-site parking;
- Provides for on-site manoeuvring due to the nature of adjacent roads which create safety issues for manoeuvring vehicles.
- Utilises the best practicable options to mitigate the adverse effects of vehicle noise.

- Includes travel demand management reducing the requirement for on-site car parking.
- Includes provision for alternative transport modes.
- Will not result in unreasonable loss of on-street car parking.
- Will not compromise pedestrian or traffic safety.

(h). Storage use and handling of hazardous substances

In assessing an application for a resource consent relating to hazardous substances, the following matters will be considered:

- Site layout, design and management to avoid, remedy or mitigate any adverse effects of the activity.
- The adequacy of the design, construction and management of any part of a hazardous facility site where hazardous substances are used for their intended function, stored, manufactured, mixed, packaged, loaded, unloaded or otherwise handled such that:
 - Any significant adverse effects of the intended use from occurring outside the intended use, handling or storage area is prevented.
 - The contamination of any land in the event of a spill or other unintentional release of hazardous substances is prevented.
 - The entry or discharge of the hazardous substances into surface or groundwater, the stormwater drainage system or into the sewerage system (unless permitted under a regional plan, resource consent or trade waste permit) is prevented.
- Necessity for secondary containment of bulk storage vessels.
- Location of and separation distance between the hazardous facility and residential activities.
- Location of and separation distance between the hazardous facility and critical facilities and lifelines.
- Location of the facility in relation to the nearest waterbody.
- Access routes to the facility, location and separation distance between the facility and sensitive activities and uses, sensitive environments and areas of high population density.
- Transport of hazardous substances to and from the site, including the tracking of waste where it is disposed off-site.
- Existing and proposed (if any currently under consideration by Council) neighbouring uses.
- Potential cumulative hazards presented in conjunction with nearby facilities.
- Potential for contamination of the surroundings of the site and sensitivity of the surrounding environment.
- Fire safety and fire water management.
- Site drainage and utility infrastructure.
- Whether the site has adequate signage to indicate the presence of hazardous substances.

- Whether adequate arrangement has been made for the environmentally safe disposal of any hazardous substance or hazardous wastes generated, including whether off-site disposal is a more appropriate solution, including whether off-site disposal is a more appropriate solution.
- Whether the site design has been subject to risk analysis, such as Hazop (Hazard and Operabilities Studies), to identify the potential hazards, failure modes and exposure pathways.
- Where the hazardous facility is located within a Hazard Area, any additional requirements to mitigate the potential effect of a natural hazard event.
- Type and nature of the existing facility.
- Whether appropriate contingency measures and emergency plans are in place.
- Whether the facility complies with the provisions of the Hazardous Substances and New Organisms Act 1996, and whether more stringent controls are required to take account of site-specific conditions.

(i). High voltage transmission lines

The proposal:

- Will not impact the ability of the transmission line owner to operate, maintain and upgrade the transmission network.
- Will not compromise the structural integrity of the transmission infrastructure.
- Will not introduce vegetation that will increase the risk of electrical hazards.
- Will cause exposure to electromagnetic fields that cannot be avoided, remedied or mitigated;
- Is in compliance with the NZ Electrical Code of Practice for Electrical Safe Distances 34: 2011, the Electricity (Hazards from Trees) Regulations 2003, and Transpower's Corridor Management Policy.

(j). Retail activity

The proposal:

- Will not undermine the vitality of Centres Areas identified in the District Plan.
- Will not undermine existing investment in infrastructure (including water, stormwater, sanitary sewer, roads and footpaths, and community facilities) in Centres Areas identified in the District Plan.