

---

ORDINARY MEETING  
OF  
WELLINGTON CITY COUNCIL  
MINUTES

Time: 9:30am  
Date: Wednesday, 30 September 2020  
Venue: Ngake (16.09)  
Level 16, Tahiwī  
113 The Terrace  
Wellington

---

**PRESENT**

Mayor Foster  
Councillor Calvert  
Councillor Condie  
Councillor Day  
Councillor Fitzsimons  
Councillor Foon  
Deputy Mayor Free  
Councillor Matthews  
Councillor O'Neill  
Councillor Pannett  
Councillor Paul  
Councillor Rush  
Councillor Sparrow  
Councillor Woolf  
Councillor Young



---

## **TABLE OF CONTENTS**

### **30 SEPTEMBER 2020**

---

<b>Business</b>	<b>Page No.</b>
<b>1. Meeting Conduct</b>	<b>5</b>
<b>1.1 Karakia</b>	<b>5</b>
<b>1.2 Apologies</b>	<b>5</b>
<b>1.3 Announcements by the Mayor</b>	<b>5</b>
<b>1.4 Conflict of Interest Declarations</b>	<b>6</b>
<b>1.5 Confirmation of Minutes</b>	<b>6</b>
<b>1.6 Items not on the Agenda</b>	<b>6</b>
<b>1.7 Public Participation</b>	<b>6</b>
<b>2. Petitions</b>	<b>8</b>
<b>2.1 Response to petition from Peninsula Parents for a Safer Community opposing sale or lease of any Wellington City Council land at Shelly Bay</b>	<b>8</b>
<b>3. General Business</b>	<b>9</b>
<b>3.1 Annual Dog Control Report 2019-2020</b>	<b>9</b>
<b>3.2 Annual Report on alcohol licensing revenue and costs for the year 2019-2020</b>	<b>10</b>
<b>4. Committee Reports</b>	<b>11</b>
<b>4.1 Report of the Regulatory Processes Committee Meeting of 9 September 2020</b>	<b>11</b>
<b>4.2 Report of the Strategy and Policy Committee Meeting of 10 September 2020</b>	<b>12</b>



---

## 1 Meeting Conduct

---

### 1.1 Karakia

The Chairperson opened the meeting at 9:33am with the following karakia.

<b>Whakatata te hau ki te uru,</b>	Cease oh winds of the west
<b>Whakatata te hau ki te tonga.</b>	and of the south
<b>Kia mākinakina ki uta,</b>	Let the bracing breezes flow,
<b>Kia mātaratara ki tai.</b>	over the land and the sea.
<b>E hī ake ana te atākura.</b>	Let the red-tipped dawn come
<b>He tio, he huka, he hauhū.</b>	with a sharpened edge, a touch of frost,
<b>Tihei Mauri Ora!</b>	a promise of a glorious day

### 1.2 Apologies

#### **Moved Mayor Foster, seconded Councillor Calvert, the following motion**

Resolved

That the Council:

1. Accept the apologies received from Deputy Mayor Free for early departure.

A division was required under standing order 27.6, voting on which was as follows:

**For:**

Mayor Foster, Councillor Calvert, Councillor Condie, Councillor Day, Councillor Fitzsimons, Councillor Foon, Deputy Mayor Free, Councillor Matthews, Councillor O'Neill, Councillor Pannett, Councillor Paul, Councillor Rush, Councillor Sparrow, Councillor Woolf, Councillor Young

**Against:**

None

Majority Vote: 15:0

Carried

### 1.3 Announcements by the Mayor

Mayor Foster announced that this week marked 150 years of Wellington City Council. On Monday, 150 years ago, the first meeting of the Wellington City Council was held with Joseph Dransfield, the Mayor, who served twice as Mayor in 1870 and again in 1878. The Mayor advised that the Council had come a long way, the population at that time was less than 5,000 people, as it was just the inner part of Wellington city. The Mayor added that it was then amalgamated with Melrose Borough, Miramar Borough, Karori Borough, Onslow Borough, Johnsonville Borough and Tawa Borough. The Mayor said that it had been a slow process of expanding the boundaries. The Mayor further added that Council would be working with younger citizens to recognise and raise understanding about what Councils does and its responsibilities, and participation and involvement in Council.

#### 1. 4 Conflict of Interest Declarations

No conflicts of interest were declared.

#### 1. 5 Confirmation of Minutes

##### **Moved Mayor Foster, seconded Councillor Day, the following motion**

Resolved

That the Council:

1. Approve the minutes of the Ordinary Council Meeting held on 26 August 2020, having been circulated, that they be taken as read and confirmed as an accurate record of that meeting.

A division was required under standing order 27.6, voting on which was as follows:

**For:**

Mayor Foster, Councillor Calvert, Councillor Condie, Councillor Day, Councillor Fitzsimons, Councillor Foon, Deputy Mayor Free, Councillor Matthews, Councillor O'Neill, Councillor Pannett, Councillor Paul, Councillor Rush, Councillor Sparrow, Councillor Woolf, Councillor Young

**Against:**

None

Majority Vote: 15:0

Carried

#### 1. 6 Items not on the Agenda

There were no items not on the agenda.

#### 1. 7 Public Participation

##### **1.7.1 Warwick Taylor – Wellington Housing Action Coalition**

Representing Wellington Housing Action Coalition, Warwick Taylor spoke to item 4.2 Report of the Strategy and Policy Committee Meeting of 10 September 2020 - Strategic Housing Investment Plan.

##### **1.7.2 Ron Beernink – Great Harbour Way Trust**

Representing Great Harbour Way Trust, Ron Beernink spoke to item 2.1 Response to petition from Peninsula Parents for a Safer Community opposing sale or lease of any Wellington City Council land at Shelly Bay.

##### **1.7.3 Patrick Morgan – Cycling Action Network**

Representing Cycling Action Network, Patrick Morgan spoke to item 2.1 Response to petition from Peninsula Parents for a Safer Community opposing sale or lease of any Wellington City Council land at Shelly Bay.

##### **1.7.4 Steph Edlin**

Steph Edlin spoke to item 2.1 Response to petition from Peninsula Parents for a Safer Community opposing sale or lease of any Wellington City Council land at Shelly Bay.

**1.7.5 Tiho Mijatov**

On behalf of Sir Peter Jackson and Dame Fran Walsh, Tiho Mijatov spoke to item 2.1 Response to petition from Peninsula Parents for a Safer Community opposing sale or lease of any Wellington City Council land at Shelly Bay.

**1.7.6 Mike Mellor**

Mike Mellor spoke to item 2.1 Response to petition from Peninsula Parents for a Safer Community opposing sale or lease of any Wellington City Council land at Shelly Bay.

**1.7.7 Tim Alexander**

Tim Alexander spoke to item 2.1 Response to petition from Peninsula Parents for a Safer Community opposing sale or lease of any Wellington City Council land at Shelly Bay.

Tabled Documents at Public Participation

**Attachments**

1 Mike Mellor

(Councillor Day left the meeting at 10:32am and returned at 10:33am.)

---

## 2. Petitions

---

2.1 Response to petition from Peninsula Parents for a Safer Community opposing sale or lease of any Wellington City Council land at Shelly Bay

**Moved Mayor Foster, seconded Deputy Mayor Free, the following motion**

Resolved

That the Council:

1. Receive the information **and thank the petitioners.**
2. Note that Council officers are bringing a paper to Councillors in October to consider the Key Commercial Terms of any commercial development agreement and proposed forms of engagement on the future of Shelly Bay Road.
3. Note that the matters raised in the petition presented by Peninsula Parents for a Safer Community will be considered by Council when it makes a decision in October.
4. Note that the matters raised in the petition have also been considered throughout the resource consent process, part of which is subject to an ongoing application for judicial review in the High Court.
5. Recommend that (as these matters will be taken into account in the October Council meeting) that the matters raised in this petition be dealt with at that time.

A division was required under standing order 27.6, voting on which was as follows:

**For:**

Mayor Foster, Councillor Calvert, Councillor Condie, Councillor Day, Councillor Fitzsimons, Councillor Foon, Deputy Mayor Free, Councillor Matthews, Councillor O'Neill, Councillor Pannett, Councillor Paul, Councillor Rush, Councillor Sparrow, Councillor Woolf, Councillor Young

**Against:**

None

Majority Vote: 15:0

Carried

**Secretarial note:** Philippa Boyens, Charlotte Hema and Rachel Robertson spoke to the petition on behalf of Peninsula Parents.

**Attachments**

- 1 Peninsula Parents
- 2 Peninsula Parents Shelly Bay Petition - Comments

**Secretarial note:** Mayor Foster moved the motion with changes from the recommendations in the officers report, clause 1 was amended as marked in red.

The meeting adjourned at 10:57am and reconvened at 11:12am with all the members present.



---

### 3. General Business

---

#### 3.1 Annual Dog Control Report 2019-2020

**Moved Councillor Sparrow, seconded Councillor Fitzsimons, the following motion**

Resolved

That the Council:

1. Receive the information.
2. Agree the content of the Annual Dog Control Report 2019-2020.
3. Adopt the Annual Dog Control Report 2019-2020.

A division was required under standing order 27.6, voting on which was as follows:

**For:**

Mayor Foster, Councillor Calvert, Councillor Condie, Councillor Day, Councillor Fitzsimons, Councillor Foon, Deputy Mayor Free, Councillor Matthews, Councillor O'Neill, Councillor Pannett, Councillor Paul, Councillor Rush, Councillor Sparrow, Councillor Woolf, Councillor Young

**Against:**

None

Majority Vote: 15:0

Carried

**Attachments**

- 1 Councillor Sparrow

(Deputy Mayor Free left the meeting at 11:31am.)

3.2 Annual Report on alcohol licensing revenue and costs for the year 2019-2020

**Moved Councillor Fitzsimons, seconded Councillor Paul, the following motion**

Resolved

That the Council:

1. Receive the information.
2. Adopt the Annual Report of alcohol licensing income and costs for the year 2019-2020.

A division was required under standing order 27.6, voting on which was as follows:

**For:**

Mayor Foster, Councillor Calvert, Councillor Condie, Councillor Day, Councillor Fitzsimons, Councillor Foon, Councillor Matthews, Councillor O'Neill, Councillor Pannett, Councillor Paul, Councillor Rush, Councillor Sparrow, Councillor Woolf, Councillor Young

**Against:**

None

**Absent:**

Deputy Mayor Free

Majority Vote: 14:0

Carried

---

## 4. Committee Reports

---

### 4.1 Report of the Regulatory Processes Committee Meeting of 9 September 2020

#### **A. Proposed Road Stopping - Land Adjoining 117 Seatoun Heights Road, Miramar**

##### **Moved Councillor Sparrow, seconded Councillor O'Neill, the following motion**

Resolved

That the Council:

1. Declare that approximately 87m<sup>2</sup> (subject to survey) of unformed legal road land in Seatoun Heights Road, Miramar adjoining 117 Seatoun Heights Road (being Lot 4 DP 8765 held on ROT WN419/26, the Land) is not required for a public work and is surplus to Council's operational requirements.
2. Agree to dispose of the Land.
3. Delegate to the Chief Executive Officer the power to conclude all matters in relation to the road stopping and disposal of the Land, including all legislative matters, issuing relevant public notices, declaring the road stopped, negotiating the terms of sale or exchange, imposing any reasonable covenants, and anything else necessary.

A division was required under standing order 27.6, voting on which was as follows:

**For:**

Mayor Foster, Councillor Calvert, Councillor Condie, Councillor Day, Councillor Fitzsimons, Councillor Foon, Councillor Matthews, Councillor O'Neill, Councillor Pannett, Councillor Paul, Councillor Rush, Councillor Sparrow, Councillor Woolf, Councillor Young

**Against:**

None

**Absent:**

Deputy Mayor Free

Majority Vote: 14:0

Carried

#### **B. Proposed Road Stopping - Land Adjoining 24 Cave Road, Houghton Bay**

##### **Moved Councillor Sparrow, seconded Councillor Condie, the following motion**

Resolved

That the Council:

1. Declare that approximately 133m<sup>2</sup> (subject to survey) of unformed legal road land in Cave Road, Houghton Bay adjoining 24 Cave Road (being Lot 74 DP 1467 held on ROT WN500/6, the Land) is not required for a public work and is surplus to Council's operational requirements.
2. Agree to dispose of the Land.

3. Delegate to the Chief Executive Officer the power to conclude all matters in relation to the road stopping and disposal of the Land, including all legislative matters, issuing relevant public notices, declaring the road stopped, negotiating the terms of sale or exchange, imposing any reasonable covenants, and anything else necessary.

A division was required under standing order 27.6, voting on which was as follows:

**For:**

Mayor Foster, Councillor Calvert, Councillor Condie, Councillor Day, Councillor Fitzsimons, Councillor Foon, Councillor Matthews, Councillor O'Neill, Councillor Pannett, Councillor Paul, Councillor Rush, Councillor Sparrow, Councillor Woolf, Councillor Young

**Against:**

None

**Absent:**

Deputy Mayor Free

Majority Vote: 14:0

Carried

- 4.2 Report of the Strategy and Policy Committee Meeting of 10 September 2020

### **Strategic Housing Investment Plan**

#### **Moved Councillor Fitzsimons, seconded Mayor Foster, the following motion**

Resolved

That the Council:

1. Agree that properties outlined in attachment 1 (of item 2.2 of the public excluded agenda of the Strategy and Policy Committee meeting of 10 September 2020) be declared surplus to operational requirements and approved for divestment.
2. Delegate authority to the Chief Executive Officer to conclude all matters in relation to the divestment of these properties, including all legislative matters, issuing relevant public notices, negotiating the terms of sale or exchange, impose any reasonable covenants and anything else necessary.

A division was required under standing order 27.6, voting on which was as follows:

**For:**

Mayor Foster, Councillor Calvert, Councillor Condie, Councillor Day, Councillor Fitzsimons, Councillor Foon, Councillor Matthews, Councillor O'Neill, Councillor Pannett, Councillor Paul, Councillor Rush, Councillor Sparrow, Councillor Woolf, Councillor Young

**Against:**

None

**Absent:**

Deputy Mayor Free

Majority Vote: 14:0

Carried

---

**Secretarial note:** Councillor Fitzsimons moved the motion with changes from the recommendations from the Strategy and Policy Committee, clause 1 was amended as marked in red.

The meeting concluded at 11:41am with the reading of the following karakia:

<b>Unuhia, unuhia, unuhia ki te uru tapu nui</b>	Draw on, draw on
<b>Kia wātea, kia māmā, te ngākau, te tinana, te wairua</b>	Draw on the supreme sacredness To clear, to free the heart, the body
<b>I te ara takatū</b>	and the spirit of mankind
<b>Koia rā e Rongo, whakairia ake ki runga</b>	Oh Rongo, above (symbol of peace)
<b>Kia wātea, kia wātea</b>	Let this all be done in unity
<b>Āe rā, kua wātea!</b>	

Authenticated: \_\_\_\_\_  
Chair

---

ORDINARY MEETING  
OF  
WELLINGTON CITY COUNCIL  
MINUTE ITEM ATTACHMENTS

Time: 9:30am  
Date: Wednesday, 30 September 2020  
Venue: Ngake (16.09)  
Level 16, Tahiwī  
113 The Terrace  
Wellington

---

<b>Business</b>	<b>Page No.</b>
<b>1.7 Tabled Documents at Public Participation</b>	
1. Mike Mellor	2
<b>2.1 Response to petition from Peninsula Parents for a Safer Community opposing sale or lease of any Wellington City Council land at Shelly Bay</b>	
1. Peninsula Parents	3
2. Peninsula Parents Shelly Bay Petition - Comments	7
<b>3.1 Annual Dog Control Report 2019-2020</b>	
1. Councillor Sparrow	23

## The Shelly Bay development means:

- \* Unsafe walking and cycling
- \* Car-dependent development
- \* The worst part of the Great Harbour Way will get worse

# Traffic Congestion

What does 6,000 cars look like?



6000



# Shelly Bay Road - Flooding



## Road Safety

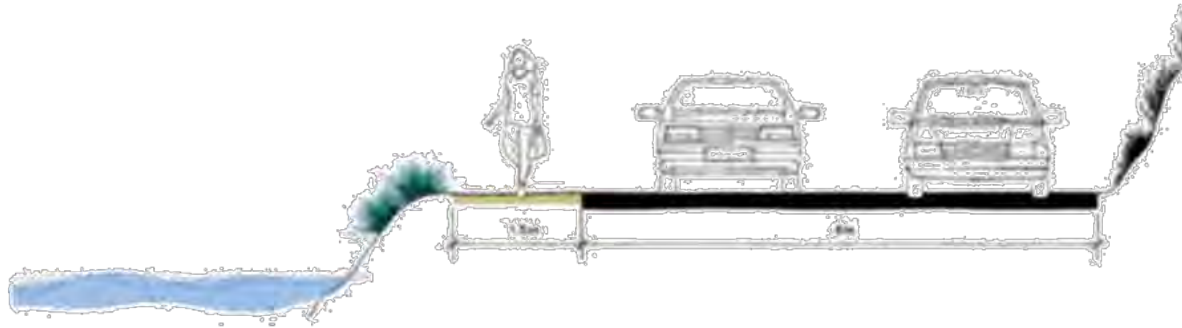

*This is this the developer's proposal for fixing Shelly Bay Road - two 3 metre vehicle lanes with a 1.5 metre footpath. However as Cycle Wellington has pointed out a "collector road" like this should be at least 14 metres requiring a footpath each side, along with a seperate cycle path on both sides of the road. Without these safety measure in place cyclists will be forced to share the vehicle lanes.*

For all our futures ...



## **PETITION TO WELLINGTON CITY COUNCIL**

**ATTN:** Mayor Andy Foster: [mayor@wcc.govt.nz](mailto:mayor@wcc.govt.nz),  
WCC Councillors [councillors@wcc.govt.nz](mailto:councillors@wcc.govt.nz),  
WCC CEO Barbara McKerrow [barbara.mckerrow@wcc.govt.nz](mailto:barbara.mckerrow@wcc.govt.nz)

**ATTACHED:** COMMENTS LEFT BY THE SIGNATORS TO THE PETITION  
FROM 21 FEBRUARY 2020 TO 31 AUGUST 2020.

# **NO MORE SALE OR LEASE OF COUNCIL LAND AT SHELLY BAY**

## Comments

Name	Location	Date	Comment
David Russell	Wellington, New Zealand	2020-02-21	"There needs to be a vote."
Kenney-Jean Sidwell	Wellington, New Zealand	2020-02-21	"I'm holding the Mayor and councillors to their word."
Andrew Mepham	Wellington, New Zealand	2020-02-21	"It was pushed through under a blanket of misinformation and secrecy, time to reengage the community"
Charmaine Love	New Zealand	2020-02-21	"Iwi voted NO to the land sale!"
Tere Harrison	Wellington, New Zealand	2020-02-21	"WCC learn from other unjust land sales - be smart end development now."
Matt Holland	Wellington, New Zealand	2020-02-21	"I strongly appose this new development. The location is completely wrong. For many reasons."
Sally-ann Moffat	Lower Hutt, New Zealand	2020-02-21	"I'm tired of underhanded behaviour by councils & developers. This has to stop."
Kiri Gerretzen	Palmerston North, New Zealand	2020-02-21	"This is my grand fathers whenua"
Ben Finucane	Lower Hutt, New Zealand	2020-02-21	"No development without significant infrastructure, its already a nightmare trying to travel from miramar into the city, its a joke"
Hansa Renata	Lower Hutt, New Zealand	2020-02-21	"How dare you Wellington Council!! Sold it off in small parcels to circumnavigate your own damn rules. Bunch of crooks like your forefathers. God have mercy on your souls."
Dan Henry	Wellington, New Zealand	2020-02-21	"The processes with this development have been flawed and the projected outcomes of the project will ruin the quality of life for Wellington residents for generations to come."
Alice Fitzgerald	Wellington, New Zealand	2020-02-21	"The sale of Shelley Bay to private developers is the worst thing to ever happen to the beautiful Eastern Suburbs. It is an absolute joke."
Christopher Baker	Australia	2020-02-21	"Definitely revoke, not all iwi, were able. Due to voting legislation Amendments."
Emma Williams	Wellington, New Zealand	2020-02-21	"This will be a disaster for the eastern bays... will damage the eco system, will impact schools, colleges, traffic will be horrendous. Already an hour from Miramar to cbd in the morning. Think about the consequences please"
Sue Burgess	Wellington, New Zealand	2020-02-21	"The quality of life as we know it in and around Shelley Bay will be changed forever. What is now a place to visit, run along, cycle along, swim and fish around will become a nightmare traffic highway with inadequate sized roads and an end to the beauty, seclusion and natural environment enjoyed by so many people."
Jennifer Puanaki	gisborne, New Zealand	2020-02-21	"Needs a revoke not all iwi were included Revoke"
Storm Sommerville	Wellington, New Zealand	2020-02-21	"The traffic is already an issue in Miramar. Takes me 20 minutes to get to Kibimie in the mornings. I do not want increased traffic in my area. I also don't want Shelley bay to be ruined by housing"
Kay Hoddy	New Zealand	2020-02-21	"The infrastructure just won't cope and valuable coastline and marine wildlife habit will be lost."
Myra Moller	Wellington, New Zealand	2020-02-21	"It is important bot to sell shelly bay"
Dee Jamieson	Miramar, New Zealand	2020-02-21	"This whole thing felt like and IS a dodgy deal. We as a community deserve better than this."
Nick Ratcliffe	UK	2020-02-21	"This is a unique part of Wellington and a real asset which needs to be protected."
Clea Matthews	Wellington, New Zealand	2020-02-21	"Short sighted, profit hungry, unsustainable approach. And unacceptable if it's true the council is not following through in the commitments that got them elected :("

Reina Puketapu	Lower Hutt, New Zealand	2020-02-21	"I am mana whenua. Leave our land alone!"
Mark Nicholas	Taranaki, New Zealand	2020-02-21	"Democracy demands this constituent consultation and vote. The expectation of "representatives" of ward residents to have consulted, reported, voted. Mayoral integrity is now in question. <a href="http://www.transparency.org.nz" rel="nofollow">www.transparency.org.nz</a>"
caroline jamleson	Wellington, New Zealand	2020-02-21	"Land is precious."
John Campbell	Wellington, New Zealand	2020-02-21	"Not one more acre"
Todd Russell	Lower Hutt, New Zealand	2020-02-21	"Ian Foster drop nuts. Showing \$ rule the city. Elected officials not representing the wishes of there constituents"
Venus Hori	Wellington, New Zealand	2020-02-21	"I never gave permission for them to sell my land."
MARGARET PALMER	WELLINGTON, New Zealand	2020-02-21	"I can see the infrastructure chaos that is going to happen with a large development like this."
nigel jeffries	Wellington, New Zealand	2020-02-21	"Traffic and infrastructure issues are serious and can't be economically resolved."
Frances Rudland	Wellington, New Zealand	2020-02-21	"The whole transaction regarding the SALE of Shelley Bay, let alone its development plan, is suspect and needs to be re-negotiated and transparent. WCC you are not doing what we elected you for!"
Billie Ruck	Wellington, New Zealand	2020-02-21	"The lwi voted no for this land sale. There's been a total disregard for this and the peninsula will not cope with a development of this scale"
Jo Rehua	Auckland, New Zealand	2020-02-21	"I'm sick of council claiming they own stolen land!!!"
Karen Kong	Wellington, New Zealand	2020-02-21	"I do not want any more volume of traffic on the peninsula it is already a nightmare getting into town during the week and weekends. I am concerned about the pollution and effect on local marine life. I also do not want to have to foot the bill for the infrastructure."
Pauline Phillips	Wellington, New Zealand	2020-02-21	"I am signing this petition as I believe the current plans for this develop are full of faults and need to be reconsidered."
carolyn sellens	wellington, New Zealand	2020-02-21	"I'm concerned about the traffic, already commuting across the peninsula and past the airport is a nightmare with airport traffic and people taking cars into the cbd as the bus service is rubbish. We can't cope with this proposal until the traffic situation is resolved"
Kathryn Jones	Wellington, New Zealand	2020-02-21	"Revote this decision please"
Sheils Anderson	Wellington, New Zealand	2020-02-21	"With sea levels rising, the cost of maintaining the road and infrastructure around Shelley Bay will become ludicrous. As it is, there is not enough road width for such heavy traffic (and this is just the Shelley Bay road)"
Adrienne Rangimokai Fruean	Waitara, New Zealand	2020-02-21	"I opposed the illegal/underhanded sale of Shelly Bay as a beneficiary of Port Nicholson Trust AND in the belief and support of this group"
Mark Reddish	Wellington, New Zealand	2020-02-21	"Traffic out of miramar is bad enough now"
Belinda Wallace	Wellington, New Zealand	2020-02-21	"I have looked at TWC's information at Shelley Bay. This development is significantly bigger than first proposed. I am not happy with the process followed by the WCC. Wellingtonians deserve a better process with more consultation."
David Tawhai-Bodsworth	Wellington, New Zealand	2020-02-22	"I oppose development as member of Taranaki lwi whanui."
Trevor Henry	Wellington, New Zealand	2020-02-22	"Wellington needs to fix its broken infrastructure before embarking on a development which can only add to that burden with likely unaccounted-for costs to the ratepayer."

Megann Devereux	Wellington, New Zealand	2020-02-22	"The infrastructure does not exist to support this development in this location. The decision to defer any decision on traffic improvement for 10 years will impact the peninsula horrendously in the next decade. I am absolutely opposed to deliberately adding to congestion and infrastructure problems."
Paul Hay	New Zealand	2020-02-22	"The WCC process is not what I'd expect from a representative council, and there are significant roading and infrastructure issues that must be addressed before any development should be considered for the site."
Steph Tims	Wellington, New Zealand	2020-02-22	"We have a voice, let's use it; Shelly Bay is a beautiful location for everyone to enjoy but scale of the proposed development will restrict all movement in and around the Peninsular, in turn affecting the environment and city-wide community. Let's revisit the options with the future in mind."
Kay Philipsen	Wellington, New Zealand	2020-02-22	"I live and drive in the eastern subs"
Julie-Ann Young	Wellington, New Zealand	2020-02-22	"Residence need a voice. We use this area all the time at our free will. Infrastructure and the second tunnel to the city need to get done prior to the implementation of a Shelly Bay development."
Maringikura Campbell	Wellington, New Zealand	2020-02-22	"I do not like the politics behind this and believe money should be going into infrusture In other failings like water pipes besides its Maori land most importantly."
terry peters	Wellington, New Zealand	2020-02-22	"Council needs to revisit their earlier decision."
Judith Roberts	Wellington, New Zealand	2020-02-22	"Wellington needs improved infrastructure and drastic changes in the transportation systems before any further development, particularly in small bottlenecked areas like the peninsula."
Margaret Ward	Paraparaumu Beach, New Zealand	2020-02-22	"Margaret Ward"
Marty Andrews	Wellington, New Zealand	2020-02-22	"Make it a reserve please"
Fiona solomon	Wellington, New Zealand	2020-02-22	"How can the cutting cope with the additional volume of traffic from Shelley Bay??!"
Sue Lafrentz	Lower Hutt, New Zealand	2020-02-22	"This site should be available for all residents of the Wellington Region. Part of it could be used for a Peter Jackson and Richard Taylor Museum plus there should be a Maori Culture Museum. This is a fabulous opportunity to use the area for tourism as well as residents with Cafes, events etc."
Sinead McGrannachan	Wellington, New Zealand	2020-02-22	"To develop Shelley Bay is beyond belief. Yet another area not for the regular folks of wellington but catered only to those with high balances in their bank accounts. Why not focus on building better and more affordable housing than increasing the density of unattainable houses for the regular income holders of NZ"
Mary & Ted Hart	Strathmore, Wellington, New Zealand	2020-02-22	"The traffic will be even more horrendous then it already is,. They should be made to deal with putting in an paying for new roading first. This area is gorgeous an should be used for tourism purposes so everyone can enjoy"
Sanja Antonijevic	New Zealand	2020-02-22	"We just moved here for a better and more private lifestyle. Making the peninsula as just one of the usual suburbs would go against its nature and the nature of its residents."
Guss Salla	Wellington, New Zealand	2020-02-22	"We already pay lots in rates etc and the roads can't handle more traffic in that area."
Leigh Page	Wellington, New Zealand	2020-02-22	"more congestion around the cutting area enough is enough"
Andy Roberts	Porirua, New Zealand	2020-02-23	"We have one opportunity to get this right for future generations."
Jenny Fellows	Wellington, New Zealand	2020-02-23	"Jenny Fellows"
Hone Baker	Christchurch, New Zealand	2020-02-23	"I don't agree with the sale of Maori owned land at all."

Ben Lee	Wellington, New Zealand	2020-02-23	"Because I voted based on this decision being reviewed as did many other people."
Robert Bruce	New Zealand	2020-02-23	"Just when you thought the new CEO was different. Same oh same o"
Scott Rooney	Sterlgsø, Denmark	2020-02-23	"The council needs to do what they say they will do, period.Listen to the people you are there to serve."
Nick Wisniewski	Nelson, New Zealand	2020-02-23	"Traffic will be to much, plus is beautiful as it is."
Sue Sutton	Wellington, New Zealand	2020-02-23	"We need to protect our beautiful Shelley Bay and not create more traffic congestion. Miramar has traffic problems which are getting worse."
Hannah Fatemi	Wellington, New Zealand	2020-02-23	"I don't want this plan to go ahead. I want the land to be protected."
David Turner	Wellington, New Zealand	2020-02-23	"I firmly believe in the need for maintaining our essential cultural character as a city and continuing the heritage of the past."
Susan Smart	Wellington, New Zealand	2020-02-23	"I'm signing thing petition as I think it needs to be redone with an open forum of all the facts"
James Saxton	Leederville, Australia	2020-02-23	"I visit Wellington often and love the place. The people should decide and not unelected officials"
Mark ARNOTT	Palmerston North, New Zealand	2020-02-23	"I care about the Miramar Peninsula..."
Sue Day	Wellington, New Zealand	2020-02-23	"I am not happy with the proposed development."
Harish Indira Patel	New Zealand	2020-02-23	"Justin had no right to make a deal with an investor without all parties insolving. including public of Wellington. Would like to see only 30% land being used for buildings and 70% land for recreation use."
Derek Fackney	Wellington, New Zealand	2020-02-23	"Derek Fackney"
Sara Gordon	Brighton, UK	2020-02-23	"It makes no sense to change the character of a unique city/coastal road combination. We need to preserve what is special to Wellington."
Heather Keith	Wellington, New Zealand	2020-02-23	"Roads are inadequate in both surface and width for the increase in traffic. Promises made must be kept. The initial and ongoing costs have not taken all probabilities into account."
Glenn Calder	Australia	2020-02-23	"Council must right the wrong"
Francis Bogmuda	Lower hutt, New Zealand	2020-02-23	"This sale was just plain wrong"
Iath moulder	tweed heads south, Australia	2020-02-23	"After going there several years ago the traffic already was a nightmare without adding this as well! Hell no!"
John Carlson	San Leandro, US	2020-02-23	"We Americans here in the U.S. were looking to you lot to be the enlightened leaders and examples of ethical, sustainability and fairness. Showing respect for the rule of law, and representing the best values and moral leadership for humanity. We know we have lost the moral high ground recently. Our profit driven capitalism without conscious has nearly ruined our chances ever leading the world in anything, unless you count the end of civilization as we know it, as a win. I as a Californian am particularly disappointed in this blatant imitation of American huderism. I mean we got away with genocide and land theft for centuries. Please don't look to us as examples of how to ruin your country, and screw the people in it. Shame on You. God Save New Zealand! Sincerely, John Carlson"
Jim Hollis	Wellington, New Zealand	2020-02-23	"It's a stupid idea."
Jon paske	Wellington, New Zealand	2020-02-23	"The potential for the benefit for all is far greater than crap housing to enrich a developer."
George Carras	Wellington, New Zealand	2020-02-23	"I'm signing because i don't want the Shelly bay project to go ahead. This will create a nightmare for all the residents in the Eastern suburbs."
Chrisanthi Kamberogiannis	Hamilton, New Zealand	2020-02-23	"Chrisanthi Kamberogiannis"



Sophie Dryburgh	wellington, New Zealand	2020-02-23	"Shelly Bay is a preservation of New Zealand Coastline at its finest. It is a sanctuary for birdlife, skinks and more. It holds historic significance and is a wonderful space for residents to enjoy a piece of New Zealand Coastline. Progression does not have to mean development and we must not prioritise profit."
Christopher Barnes	Perth, Australia	2020-02-23	"Ultimately, Wellington airport is sort of in the wrong place, now that it is so busy and set to get even more so. Could the crazy solution be to move the airport to the mainland north of the City and do a deal with the developers to create a large car park on the vacated airport site (along with any new businesses) before people arrive at Miramar with their cars? A local shuttle bus would ease congestion. Wellywood can be free of the incessant jets. Cassel can have some concession INSTEAD of Shelley Bay. The main difficulty is the TUNNEL congestion. Wellington will have to build a suitable new highway route on the south-west coastal route. ( I know nothing about the detailed geographical issues). Urban sprawl has to have limitations. All I know is that if Shelly Bay is over developed, that it will lose its intrinsic appeal and value. It happens to be IWI LAND too!"
Jacob Snogdal	Odder, Denmark	2020-02-23	"This is not right!"
dru walker	Dorchester, UK	2020-02-23	"You must listen to the people"
Gloria Alvarez Valle	Zaratán, Spain	2020-02-23	"Stop that horrible "carneggedon""
Micheal Brown	Wellington, New Zealand	2020-02-23	"I want a better Wellington."
Chris Osborne	Wellington, New Zealand	2020-02-23	"The original method for dividing the land in to smaller parcels to circumvent iwi voting requirements was illegal."
Jenny Dougan	Dumfries, UK	2020-02-23	"No more pollution, no more detriment to the natural environment just for money and greedy property developers. Don't build on scenic areas with natural wildlife build in rubbish tips that would be more productive or existing derelict buildings rebuild there."
Helen Peterson	Sherwood, US	2020-02-23	"You need to listen to your citizens. They should have a voice and a vote in what is going on here."
Julie Sobchack	Salt Lake City, US	2020-02-23	"I cannot vote for this, as I am not a resident of NZ. But I live in a country where developers have run rampant too many times, and have caused more problems than anyone was told about or could even imagine. Vote against this desecration of your beautiful land. It is NOT sensible."
Allan Gestro	Wellington, New Zealand	2020-02-23	"its vital for recreational fishing so families can take young kids fishing no good for them off the rocks slowly bit by bit we are losing the availability of the wharves to fish off not good"
Christine Godetz	Wellington, New Zealand	2020-02-23	"Traffic is horrendous now, add more to it and you'll have a serious nightmare"
Tina Groark	Wellington, New Zealand	2020-02-23	"The whole process seems flawed - full transparency"

Kenneth Gimpelson	Wellington, New Zealand	2020-02-23	"In this time of rising sea levels, new high-density 5 story apartment blocks with over 300 dwellings, plus businesses, a retirement community, and a hotel located barely above the water line will displace: * An important cycle way for the city * A Blue Penguin habitat * A strong art colony * An eatery that is iconic because of its environment Representatives of The Wellington Company are happy to tout a "slightly widened" road and walkway within the bounds of the property, at a cost of \$10 million, payed by the tax payer. If you've seen the mock-up, you know that it is not really enough space for bikes, in spite of what they say. What about the coastal road on either side of the development? What about the already congested intersections near The Cutting and roundabout near the airport? What about the never-ending airport expansion plans? Revitalizing the area is not a bad motivation, but the council's consent for the project in it's current form is anything but forward thinking or well planned."
Cordelia W	Wellington, New Zealand	2020-02-23	"The council have already destroyed the natural habitat around Shelly Bay by implementing the new walkway. An overgrowth of development around that coastline will impact so many species, increase pollution levels, and make Miramar Ave a nightmare to traverse (it already is, but these people have no idea what it's like to be a pedestrian dodging traffic). I find it ludicrous that we're supposed to be lessening carbon emissions as a city, yet profiteering ventures such as this is the Council's top priority. Grrrr!"
Angela Griffiths	Wellington, New Zealand	2020-02-23	"Alongside the traffic concerns; I'd like to include the impact of Climate Change on rising sea levels... makes this development a lemon."
Hajnalka Mayor	Wellington, New Zealand	2020-02-23	"The traffic is already a nightmare, 40 minutes every morning to get my kid to school on the other side of the tunnel."
Karen Ramsey	Wellington, New Zealand	2020-02-23	"I agree, this would be a absolute nightmare."
Robb Morison	Wellington, New Zealand	2020-02-23	"This issue effects all Wellington residents, think of them."
Travis Gray	Seatoun, New Zealand	2020-02-23	"The outcomes claimed by the developer and WCC are disingenuous. It is all about profit and allowing a special location of quiet relaxation to be bought and enjoyed by the privileged in our society only. They are salivating. In addition there has been no movement in the last 20 years to address traffic infrastructure after the 1990's boom of infill housing in Miramar. The suburb is full and cannot absorb any more large scale developments and certainly nothing like this. In addition this area of Miramar is a quiet area to be enjoyed by the locals in the weekends because they can't actually get out of their suburb due to traffic congestion. Other suburbs can generally get out or have excellent recreational infrastructure like Karori. So the situation is cyclic. WCC, ... get your infrastructure sorted with redundancy first like the rest of the world does it, THEN have a conversation with the locals as to whether it is acceptable to have any more people move in! Make sure that this suburb is kept upgraded and ma"
Brandon Gloyn	Wellington, New Zealand	2020-02-23	"The traffic issues that face the eastern suburbs are already at a fever pitch. There is no sense in making an already existing problem worse. It also isn't going to be affordable housing for anyone but the super elite which is not what we need."

Bruce Spedding	Lower Hutt, New Zealand	2020-02-23	"As a watersports enthusiast I recognise the importance of access to recreational spaces. This area is too important to Wellington to relegate to accommodation and commuter traffic, it should be carefully developed to maximise it's value recreationally and culturally to the whole region. There is too much self interest fast tracking and manipulation of the democratic process by unelected officials."
Aleissandros Paris	Penrith, UK	2020-02-23	"High density development has been totally discredited and is no way to build in the modern world. Human beings have not evolved to live in high density populations, and have a strong tendency to degenerate in such areas. Anyone who supports such developments should be made to live in the heart of them."
Dave Wolland	Whangarei, New Zealand	2020-02-23	"I believe this proposal it entirely inappropriate for the area and should be stopped immediately!!!"
Brent Backhouse	Wellington, New Zealand	2020-02-23	"The need to do the right thing"
Clare Aird	Wellington, Wellington, New Zealand, New Zealand	2020-02-24	"Im signing because the infra structure is so neglected it can barely cope with the current demands on basic services such as water and sewerage let alone transport. The short sited small minded attitude of our council has got to be reigned in."
Marie Heffernan	Wellington, New Zealand	2020-02-24	"This process has been shonky from the start - it needs to be reviewed. Additionally WCC has enough expense dealing with the existing infrastructure problems without continuing to overload the Peninsula!Do the right thing and review the decision!"
Tanya Lovington	Wellington, New Zealand	2020-02-24	"I believe WELLINGTON as a whole benefits from this unique piece of land for recreational purposes. It's a huge asset to the city and well used through the week and weekends. The artistic community have space there and the cafes create a wonderful community feel. I BBC would love to see this developed for further artistic spaces - studios created for local artists to rent, the recreational, diving, fishing, cycling, walking be left so the greater WELLINGTON region can enjoy. Turning into elitist apartment living and increasing the divide between haves and have nots feels terrible wrong. Creating residential space and another busy road with years of trucks for development seems terribly wrong when the city is in desperate need of addressing other essential infrastructure like water and transport."
Robbie Schneider	Lower Hutt, New Zealand	2020-02-24	"I support safety in the community."
Adrian Reid	Lower Hutt, New Zealand	2020-02-24	"Neroli Bird"
Safari Hynes	Lower Hutt, New Zealand	2020-02-24	"Give the land to the people"
Maye Fitzgerald	Wellington, New Zealand	2020-02-24	"The Wellington councillors are corrupt!!!! Never voting for them again!"
Ahorangi Wharu	Wellington, New Zealand	2020-02-24	"Give us our land back. You've taken enough from us already."
April Lundy	Wellington, New Zealand	2020-02-24	"Ian Cassels is CORRUPT!!!!!! Always has been. Don't let this development happen!!!!"
Peter Dent	Lower Hutt, New Zealand	2020-02-24	"I am totally against the current trend of councils and developers seeing how many people can be squeezed onto the square metre, not just the Peninsula destroying the traditional open living and open spaces of suburban New Zealand"
Natalia McKenzie	Wellington, New Zealand	2020-02-24	"I live on the Miramar Peninsula."
Debbie Corder	Masterton, New Zealand	2020-02-24	"I grew up in Wellington from 1975-2005 and I just love Shelly Bay the way it is. I feel that if this land is touched it will be ruined. Leave it alone."
sue burgess	Wellington, New Zealand	2020-02-24	"I'm seriously concerned about traffic around what is one of the most beautiful spots in Wellington; it should be made a Heritage site."

Clare Burgess	Wellington, New Zealand	2020-02-24	"It will ruin the peninsula - which doesn't have the infrastructure to support it and it's the most beautiful natural area in Wellington"
Cat Weich	New Zealand	2020-02-24	"This is a really bad idea. The area does not have the space or access to warrant such a level of development."
Frank Boxman	Groningen, Netherlands	2020-02-24	"Quality over quantity."
Sam Hyde	Wellington, New Zealand	2020-02-24	"Stealing is wrong"
Courtney Jenndale	Wellington, New Zealand	2020-02-24	"This development is a terrible idea. It's a very illegal cash grab for Cassels and it needs to be stopped."
Matt Nathanson	Wellington, New Zealand	2020-02-24	"Wellingtonians (including myself) voted for a new mayor who promised TRANSPARENCY. There are clearly dodgy deals still going on behind closed doors. Andy, it's time to act upon your promise and be the voice that we voted for."
Ellen Brown	Wellington, New Zealand	2020-02-24	"I don't believe that the people who are fighting for this development have best intentions."
Julia Bracegirdle	Wellington, New Zealand	2020-02-24	"I don't want to see a beautiful natural area that could be our 'Stanley Park' destroyed. Plus the roading is not capable of handling the extra traffic that will ensue if it is developed."
Lynn Coory	Wellington, New Zealand	2020-02-24	"Not all land needs to be turned into a housing development. So many more viable options for this area that would benefit the city, the residents and visitors. The eastern suburbs has enough traffic problem without adding 100's of additional vehicles. The current road is a delightful scenic area to take visitors, what restrictions will there be running through a high density housing complex? And, a ugly addition to the area"
Wayne Makarini	Wellington, New Zealand	2020-02-24	"WCC getting bought off by developers."
Sylvia Margaret	Kapiti, New Zealand	2020-02-25	"THE WAIHIA DRIVE IS BEING BUILT ANYWAY SO WHY NOT TAKE ADVANTAGE OF THIS OPPORTUNITY TO DEVELOP IT."
alana Vere smyth	Wellington, New Zealand	2020-02-25	"This is a historic, heritage and defences area, that should not be modernised"
Kathleen Farrelly	New Zealand	2020-02-25	"The roads will not cope with the traffic."
Liam Ecclestone	Taupo, New Zealand	2020-02-25	"Does the WCC not understand this is the reason we voted Justin Lester out? The people of Wellington are against this development. I trusted Foster to be more transparent and listen to the voice of the people but I guess I was wrong."
Pete Campbell	Taupo, New Zealand	2020-02-25	"I live in the eastern suburbs and this development would have a devastating effect not only on the traffic, but on the environment and wider Wellington community."
Jacqueline Myers	Wellington, New Zealand	2020-02-26	"There is a great opportunity to develop this space into a community focused area, with areas to acknowledge our heritage, support new businesses and to focus on sustainability and research. This wider more holistic approach will feedback into our economy, attract more visitors and provide new spaces for our up and coming young people."
Magnus Hjert	Wellington, New Zealand	2020-02-26	"Cobham Drive and its connecting roads cannot handle increased traffic flow on this scale. For this to be even remotely feasible, SH1 first needs to be dual carriageway all the way to the airport. But even then, Wellington needs more areas like Shelley Bay - not fewer. If housing is required, fill in the bomb sites in town vacated by earthquake damage prone buildings - don't plan for thousands of people in thousands of cars to travel 5 km to town and back every day for work."
Paul Mckelvey	Wellington, New Zealand	2020-02-26	"Traffic is a nightmare now trying to get to the Terrace tunnel from Miramar, on average by car it is taking an hour, to get home to Titahi Bay 1hr 30, not good enough. WCC Spend money of the infrastructure to get Wellington moving"

tara belle	newplymith, New Zealand	2020-02-26	"There are way to many cars on this road already. The counsel can't take care of our roads as it is let alone adding more to the problem"
Linda Brown	Melbourne, Australia	2020-02-26	"I'm signing because I think there are too many beautiful places on this planet that have been chopped out to make way for ugliness like traffic etc....Let's not turn our world into a totally ugly place theses too much UGLY in the world let's preserve the beauty we have left."
Lefki Marsh	Wellington, New Zealand	2020-02-26	"I care about the peninsula and traffic."
Rachel Hjert	Wellington, New Zealand	2020-02-26	"I run around the bays and this won't be very nice anymore"
Leah Saan	Wellington, New Zealand	2020-02-26	"I believe this development would have a devastating effect on the peninsula. I myself live in Miramar and the traffic getting into the city every morning is already a nightmare. I couldn't imagine adding thousands of more cars to the road. Plus it's clear that the road along Shelly Bay is not equipped for such traffic. This whole thing is a terrible idea."
Tamara Tuatini	Wellington, New Zealand	2020-02-26	"Last year I purposely voted for the counsellors who were AGAINST this development. To now say there won't be another revote is beyond disappointing. Is democracy dead in Wellington?"
Harry Palmer	Wellington, New Zealand	2020-02-26	"The fact that Ian Cassels paid 2 million for the land just shows the corruption that has gone on with the WCC. I'm not surprised at all they lied about having a revote. They're his puppets and will do whatever he wants."
Maxine Carroll	Porirua, New Zealand	2020-02-26	"Oppose sale of land."
Sergio Ayrosa	Wellington, New Zealand	2020-02-26	"Any development in that area will have to take into account the impact on access which is already compromised due to Aiport traffic and the urgent need for infrastructure - as it is we have ongoing sewage and waste water disposal into the ocean. There needs to be broad community consultation."
Serena Johnston	Wellington, New Zealand	2020-02-26	"It will probably be undermined by climate changes and sea levels and rate payers should not have to pay for that. This council has declared that they will consider climate change in all decisions. Let's get them the chance of reconsidering this decision"
Judith Cowley	Wellington, New Zealand	2020-02-26	"That land should be for the public to enjoy"
Bill Collins	Porirua, New Zealand	2020-02-26	"It is wholly unacceptable that the local people have been ignored. This is not progress, it's setting up for expensive failure and huge problems in the near future."
Neil Lorimer	Palmerston North, New Zealand	2020-02-27	"Neil Lorimer"
Bette Cosgrove	Wellington, New Zealand	2020-02-27	"I oppose the illegal sale of this land at a giveaway price to a developer who has convinced (or lied to) too many people to influence the WCC to now ignore democratic process."
Lesley Walls	Wellington, New Zealand	2020-02-27	"The planned development is far too big for the area and will further exacerbate the existing traffic issues impacting the eastern suburbs. There seems to be no definitive plan for Shelly Bay road. The current road will not be able to cope with the construction traffic and future residents vehicles. Widening the road will destroy a nice scenic drive and have environmental impacts for little blue penguins etc. There also seems to be no clear understanding as to who will be responsible for the significant costs of any improvements/widening required for Shelly Bay Road."
costa christie	Wellington, New Zealand	2020-02-27	"I'm signing because I would like to see another vote on this important issue."
Nicole Blackie	Wellington, New Zealand	2020-02-27	"Climate change- it's not responsible land development"
Philippa Ward	Lower Hutt, New Zealand	2020-02-28	"Philippa Ward"

Roger Wilson	Wellington, New Zealand	2020-02-28	"We used to live in Shelly Bay Rd. in the cottage on the same property as the engineering works in the Nissen hut. Now we live directly opposite the old air force base so have a visual vested interest too in calling a halt to the nonsense."
Eddie Stanley	Wellington, New Zealand	2020-02-29	"Keep it for everyone to enjoy."
Kate Ross	Whakatane, New Zealand	2020-02-29	"I want to see the area safe for children going to school and for workers getting to work in a reasonable time frame, not having to sit in traffic jams every day."
Phillipa Dajnowski	Wellington, New Zealand	2020-03-01	"This development will ruin Shelly Bay and cost the ratepayers a lot of money with infrastructure that will need to be upgraded. If they are going to build houses just don't build so many and make space for freedom campers and families to come and enjoy."
Russell Tregonning	Wellington, New Zealand	2020-03-02	"This development is entirely inappropriate for such a fragile area. The climate scientists are telling us quite clearly that we need to move away from the coast when building new housing developments. The coastal road already requires almost constant repairs. The heavy traffic moving along this narrow winding road for up to 13 years is completely unacceptable for many who use the road as recreation for cycling, walking, swimming, fishing etc. There is a much better solution for Shelly Bay and the adjacent Watt's peninsula -- a beautiful marine and heritage Park. This is a once in a lifetime opportunity."
Virginia McCarty	Wellington, New Zealand	2020-03-04	"Will WCC be committing ratepayers money to paying Developers infrastructure costs? Make what we have fit for purpose first please."
Jacqui WEBER	Wellington, New Zealand	2020-03-06	"I'm sick of the congestion already. If u want Development build in Kapiti. Plenty land out there."
ALLAN LARDER	NORTH SHORE, New Zealand	2020-03-06	"This is manifestly unjust and corrupt!!"
Andrew Best	Wellington, New Zealand	2020-03-06	"I believe we need any earlier decisions reviewed with current information and without voting on party lines but rather voting with true community representation in mind"
Allen Shanks	Wellington, New Zealand	2020-03-06	"I do not agree with what is proposed and I think that there's something smelly about Shelly."
simone chesterman	wellington, New Zealand	2020-03-07	"This land belongs to the people. Please leave some open space for the next generation x"
Polly Thomas	Wellington, New Zealand	2020-03-10	"I go to the shelly bay area every couple of weeks, to fish, to walk to the memorial and just enjoy the area. Would be a shame to destroy it's unique beauty."
Gee Cojanu	Macomb, US	2020-03-13	"i believe it is unnatural, and not only that but not environmentally beneficial nor is it contributing to anything great"
Dawn Taylor	London, UK	2020-04-12	"To do that this beautiful part of Wellington is criminal! It is going to ruin the whole drive around the bays. Keep it for all the people, not just the wealthy."
Geraldine Shaw	wellington, New Zealand	2020-08-25	"I don't believe the peninsula can cope with development. Our schools are already full and our traffic is already at max. Shelley Bay is like our little piece of forest paradise please don't take it away."
Jenny Boyle	Little Mountain, Australia	2020-08-26	"We've seen what happens under circumstances like this here in Aus. Wellington is such a beautiful city. Don't allow it to be wrecked by those with vested interests."
Paul Weatherhead	Hunternville, New Zealand	2020-08-26	"Paul Weatherhead"
Manasee Asgekar	Wellington, New Zealand	2020-08-26	"It's a ridiculous project, Ian Cassels needs a reality check. This is going to put more pressure on the traffic in the tunnel or Cobham drive in general."
Glen Christie	Wellington, New Zealand	2020-08-26	"It's a crazy idea. Keep this jewel for all Wellingtonians"
Joanne Rogers	Auckland, New Zealand	2020-08-26	"Signing because I love the Miramar peninsula I love the trees, the walks the beaches. We all need to treasure this small paradise for future generations."

Teresa Olszanka	Highett, Australia	2020-08-26	"No, no, no"
Sea Rotmann	Wellington, New Zealand	2020-08-26	"I'm signing because the way this whole business was conducted was borderline (if not outright) corrupt and that Shelly bay is currently a sanctuary for all of us to enjoy. I cannot imagine how the narrow and fragile coastal road will cope with the heavy traffic, which will no doubt cause further congestion to the entire peninsula. Such a huge development will destroy the natural environment and peacefulness of the area. We don't want it!"
Christie Holmes	Wellington, New Zealand	2020-08-26	
Stuart Gray	Auckland, New Zealand	2020-08-26	"Leave Shelley Bay as a public space to enjoy"
Margaret Van Altena	New Plymouth, New Zealand	2020-08-26	"It is historical land. The decision by the then Council did not follow the principles of a democracy. It is a beautiful area of Wellington. Leave it as it is."
Greg Colson	New Zealand	2020-08-26	"The development in its present form will not be good for the Mīrimar peninsula"
Leilani wright	wellington, New Zealand	2020-08-26	"Keep it the way it is"
Neale Dickson	Wellington, New Zealand	2020-08-26	"I want something done here."
nathan taare	Wellington, New Zealand	2020-08-27	"I do not agree with the development. The land should stay with Iwi."
Stephanie Sinclair	Wellington, New Zealand	2020-08-27	"It's an important community resource"
Wendy Hynes	Wellington, New Zealand	2020-08-27	"Not one more acre."
Joyce Stephens	Wellington, New Zealand	2020-08-27	"I oppose development of a beautiful landscape for whānau."
Maria Shadbolt	Wellington, New Zealand	2020-08-27	"The road and community can't absorb this quantity. Sea levels rising an irresponsible development at sea level."
bill Hickman	Wellington, New Zealand	2020-08-27	"I believe this process lacks transparency and it's benefits are limited to a small number of investors at considerable cost to ratepayers and Iwi."
Terese Macdonald	Wellington, New Zealand	2020-08-27	"I am a member of Te Ati Awa"
Sherryn Strickland	Wellington, New Zealand	2020-08-27	"It is a poorly engineered proposal, illegally jerrymandered."
Celia Billing	Auckland, New Zealand	2020-08-27	"It doesn't suit that area and it should be left as it is just give the buildings a new license plate"
Tui Brown	Umina Beach, Australia	2020-08-27	"Leave our whenua alone"
Naomi Law	Palmerston North, New Zealand	2020-08-27	"Because I was born and raised in Wainuiomata but family from Wellington"
Lisa Bailey	Wellington, New Zealand	2020-08-27	"This land should not be sold off"
rawiri evans	wellington, New Zealand	2020-08-27	"no to selling this land return to Iwi"
Richard Lindsay	Wellington, New Zealand	2020-08-27	"I care about safety and our environment"
Tina King	Morden, UK	2020-08-27	"It is crazy to even think of doing such things"
Britina Edwards	Porirua, New Zealand	2020-08-27	"Because the land is not yours to sell."
Judy Hart	wellington, New Zealand	2020-08-27	"Tidy it up but treasure it for all."
Ingrid Rodgers	Hastings, New Zealand	2020-08-28	"I live in the Wairarapa and I honestly believe sale or lease of this land is wrong"
David Mansfield	Wellington, New Zealand	2020-08-28	"Nothing ever good comes with change."
Basil Bouzoukis	Wellington, New Zealand	2020-08-28	"No infrastructure to deal with the increase traffic"
Judy Dumbieton	Wellington, New Zealand	2020-08-28	"I'm signing because spending half a billion dollars on a waterfront development in the face of rising sea levels is absolutely bonkers."
K Howlett	Wellington, New Zealand	2020-08-28	"This development is poorly planned and not at all appropriate for the peninsula"
Lynne Marshall	Wellington, New Zealand	2020-08-28	"This subdivision is a very bad decision. The road around Shelly Bay to Worsley Bay is a public road and the drive around the peninsula delights both locals and overseas visitors. Taking away access or making it only one way would be horrible."
Terri Bullock	Wellington, New Zealand	2020-08-28	"I don't want Shelly Bay to become another future alum of Wellington. It should be a massive park for all Wellingtonians"
Robin Halse	Wellington, New Zealand	2020-08-28	"The whole decision making and sale process was corrupt."
Rod Page	Wellington, New Zealand	2020-08-28	"I support the mayor"

Sharlene Macate-Davis	Paraparaumu Beach, New Zealand	2020-08-28	"He uri ahau no te kainga nei"
Susan Harper	Wellington, New Zealand	2020-08-28	"The land was lent not given, and the "sale" is dubious. This is a chance to avoid doing a Bastion Point/Ihumātao."
Wendy Leahy	Wellington, New Zealand	2020-08-28	"You're not listening... The actions of developers and the previous council were riddled with corruption. Mr Cassells, we don't want your ghastly development, for a multitude of reasons. Go and ruin your own backyard, and take your dodgy dealings with you."
Sadhna Wati	New Zealand	2020-08-28	"Because I care"
Georgina Tamaki	Hamilton, New Zealand	2020-08-28	"It's not for sale!!!!"
Julia Hennessy	Wellington, New Zealand	2020-08-28	"This is Maori land and appears that full voting was not undertaken."
Sascha Perfect	Wellington, New Zealand	2020-08-28	"I would like WCC to do a revote. There is a lot of public concern around this site. I believe this development needs to be re thought as there are not enough roads on the peninsula to support this high density level of housing. I am not against some development but what Cassels has proposed is not suitable and this company is just in it for economic gain. The WCC should be more responsible with how developments are resourced and consented and they should be protecting Wellington unique coastline."
Leah Lewis	Wellington, New Zealand	2020-08-29	"Please rethink this is such a terrible idea. 1 hour to get into town at present a non working bus system since you changed all the stops these crazy decisions need to end. You are systematically ruining Wellington"
Amanda Costea	Flagstaff, US	2020-08-29	"I visit WELLINGTON three times a year and don't want to see the traffic nightmare that looks to be happening. Do the right thing for our children future"
Nichola Bracken	Wellington, New Zealand	2020-08-29	"I'm ngati Kahungnu and ngati Toa"
Renee Alleyne	Nelson, New Zealand	2020-08-29	"Shelley Bay is a nice quiet haven and doesn't have the capacity for high density developments Listen to the locals. It's a treasure as it is Keep it that way"
Amar PR	Wellington, New Zealand	2020-08-29	"I want the beautiful roads & surroundings to be better too"
Christine Patelesio	Wellington, New Zealand	2020-08-29	"I'm signing this petition cause I can and want."
Sarah Potter	Richmond, Nelson, New Zealand	2020-08-29	"Where do I start? In summary filling this space with high density housing will cause lots of problems, as outlined by the petition and supporting community committee. I grew up in Seatoun and am very aware of the impacts in the area of more and more houses and cars."
Sam Hyde	Wellington, New Zealand	2020-08-29	"This process reeks of corruption between the council and developers including the board of the port Nicholson trust who did not represent a clear mandate not to sell."
Andrew Borrie	Napier, New Zealand	2020-08-29	"Of the negative impact this will have on the area"
Carlos Lagreze	Wellington, New Zealand	2020-08-29	"I'm agreed with you"
Andrew Price	Titirangi, New Zealand	2020-08-30	"I used to live in Wellington. Shelly Bay is a rare last iconic area that should be left open for recreational use. The last thing I or any tourist wants to see flying into Wellington is more shoebox apartments. It would be a bane on the city."
Anne Anglim	Wellington, New Zealand	2020-08-30	"I'm signing this petition because the current proposed development by Ian Cassells is a recipe for disaster for local residents and wellington ratepayers. Already traffic to and from Miramar is a nightmare at peak hour. So many times I have turned my car around rather than enter the traffic slog into Wellington CBD. If Shelly Bay goes ahead I can see myself relocating rather than face this traffic influx."



Tim Sutton	Wellington, New Zealand	2020-08-30	"Miramar Peninsula is already overloaded with infrastructure struggling with traffic volumes. This is a very bad idea."
Ross Sutton	New Plymouth, New Zealand	2020-08-30	"This is such a great community asset. Let's not lose it!"
Wayne Brown	Christchurch, New Zealand	2020-08-30	"I think the WCC are being corrupt"
Stephnie Roberts	Wellington, New Zealand	2020-08-30	"I live in Miramar. I value Shelly Bay, and the wider Miramar Peninsular. In addition to my belief that apartments are not the best use of this land, I am appalled by the prospect of even more traffic adding to the current congestion, which is already at a slow crawl at peak times every day, not just week days."
Diana Tuckwell	Lower Hutt, New Zealand	2020-08-30	"DIANA TUCKWELL"
Karen Pedder	Wellington, New Zealand	2020-08-30	"This CANNOT happen, traffic is already a nightmare and this will make it impossible to leave and get to Miramar, there is already toooooo many cars. These people who want this need to try and live in Miramar!!!"
John Herrick	Wellington, New Zealand	2020-08-30	"The existing roading infrastructure on the Miramar Peninsula is already at breaking point"
Daniel Sellar	Wellington, New Zealand	2020-08-30	"We should try to preserve as much of the green space around Wellington as we can"
Garth Baker	Wellington, New Zealand	2020-08-31	"Keep the bays for everyone by limiting the road use to cyclists and pedestrians."
Geoff Henry	Wellington, New Zealand	2020-08-31	"This land MUST be freely accessible to all Wellingtonians. We also need unobstructed public access to the beaches and waterfront."
Trevor Hughes	New Zealand	2020-08-31	"It's irresponsible to proceed with this development without substantial improvements to the roading system including a second Mt Vic tunnel."
Anna Woolhouse	Wellington, New Zealand	2020-08-31	"This 'Council-owned' land is actually our land. Too lovely to develop for the few"
Rachel Keen	, New Zealand	2020-08-31	"I do not want more cars and traffic on the peninsula. It's a terrible idea. I VOTE NO!!"
Dallas O'Neil	Wellington, New Zealand	2020-08-31	"I read the article by Nicky Hager, am astounded this is still being considered."
Oli Brooke-White	Wellington, New Zealand	2020-08-31	"This whole project is ill-conceived and a future traffic disaster. Stop the sale NOW."
Kathleen Beeler	Auckland, New Zealand	2020-08-31	"Mostly because of traffic which already is terrible on Cobham drive. The Miramar Peninsula is too cut off to support anymore housing. Perhaps open Airport dr or build a second tunnel before anymore development."
Craig Vanston	Wellington, New Zealand	2020-08-31	"A large scale housing development, with massive holes in supporting infrastructure funding on land purchased surreptitiously from the iwi owners, is not what I and many others who live on the motu want. Stop this now."
Tane Gardiner	Hamilton, New Zealand	2020-08-31	"It shouldn't be sold"
Ruth O'Brien	New Zealand	2020-08-31	"Infrastructure nowhere near adequate for what's planned! Gorgeous little swimming spots & walks should be retained for future generations. Once developed - gone for good!!"
Alanna Krause	Wellington, New Zealand	2020-08-31	"See the investigative journalism done by Nicky Hager - something is really fishy about this deal. I'm a big supporter of denser housing, but not on contested Maori land. Plus, we need real investment in public transport instead of putting yet more cars on crumbling roads."
AmandaLee Smith	Wellington, New Zealand	2020-08-31	"I think it should not be developed. Leave as a reserve for all our people!"
Isabelle Peet	Wellington, New Zealand	2020-08-31	"I love Shelley bay and it shouldn't be sold for commercial development"
Will Quinn	New Zealand	2020-08-31	"I want Shelley bay to remain as it is."
Sandra Edlin	Wellington, New Zealand	2020-08-31	"This was a dodgy deal from the start"

---

Carol Anderson	Wellington, New Zealand	2020-08-31	"Short-sighted. Costly. Surely there are more urgent infrastructure needs. Elected officials are elected to LISTEN to the people that elected them.. unless you're a Trump."
Caroline Campbell	Wellington, New Zealand	2020-08-31	"I believe in public access to our coastline and council assets."
Amanda Fugle	Auckland, New Zealand	2020-08-31	"I don't want Access to Shelly Bay for recreational activities (biking, walking, running, swimming, fishing and enjoying the beaches) to be restricted or impacted by the proposed development. I'm also concerned about the increased pressure and impact on the existing traffic congestion issues in Eastern suburbs resulting from the proposed high density development. Also I think it's crazy to invest in building property so close to the coastline when we know NZ will face significant problems due to climate change and rising sea levels in the future."



**“No, I’m not coming down ...  
I’ve been walked by everyone  
in this flippin’ family today!”**

