

**Parliament Precinct  
Future  
Accommodation  
Strategy (FAS)**

Integrated Transport  
Assessment

**Parliamentary Service**

Reference: 255585

Revision: E

9 September 2022

**aurecon**

*Bringing ideas  
to life*

# Document control record

Document prepared by:

**Aurecon New Zealand Limited**

Level 4, 139 Carlton Gore Road  
Newmarket Auckland 1023

PO Box 9762

Newmarket Auckland 1149  
New Zealand

**T** +64 9 520 6019

**F** +64 9 524 7815

**E** auckland@aurecongroup.com

**W** aurecongroup.com

A person using Aurecon documents or data accepts the risk of:

- a) Using the documents or data in electronic form without requesting and checking them for accuracy against the original hard copy version.
- b) Using the documents or data for any purpose not agreed to in writing by Aurecon.

Document control						
<b>Specification title</b>		Integrated Transport Assessment				
<b>Document code</b>		255585-0600-RPT-CC-001-A	<b>Project number</b>		255585	
<b>File path</b>		https://aurecongroup.sharepoint.com/:b:/r/sites/255585/5%20Deliver%20Design/001%20-%20Master%20Documents/501%20Correspondence/Out/20210716%20NOT%20ISSUED%20-%20Resource%20Consent%20Reports%20-%20Draft/255585-0600-RPT-CC-001%20%E2%80%93%20Integrated%20Transport%20Assessment%20Report.pdf?csf=1&web=1&e=k4xzco				
<b>Client</b>		Parliamentary Service				
<b>Client contact</b>		<b>Client reference</b>				
<b>Rev</b>	<b>Date</b>	<b>Revision details/status</b>	<b>Author</b>	<b>Reviewer</b>	<b>Verifier (if required)</b>	<b>Approver</b>
A	2021-07-16	Draft for Client Review	Shonel Sonakjee	Katherine Eveleigh	Katherine Eveleigh	Marcus Welby
B	2021-08-04	Final	Shonel Sonakjee	Katherine Eveleigh	Katherine Eveleigh	Marcus Welby
C	2021-09-16	Final (incorporation of tbig and SPA comments)	Shonel Sonakjee	Katherine Eveleigh	Katherine Eveleigh	Marcus Welby
D	2022-02-15	Final (incorporation of tbig and SPA comments)	Shonel Sonakjee	Katherine Eveleigh	Katherine Eveleigh	Marcus Welby
E	2022-09-09	Final (Revised RC Issue)	Shonel Sonakjee	Katherine Eveleigh	Katherine Eveleigh	Marcus Welby
<b>Current revision</b>		<b>E</b>				

Approval			
<b>Author signature</b>		<b>Approver signature</b>	
			
<b>Name</b>		<b>Name</b>	
Shonel Sonakjee		Marcus Welby	
<b>Title</b>		<b>Title</b>	
Transportation Engineer		Project Manager	

# Contents

<b>1</b>	<b>Introduction</b>	<b>3</b>
1.1	Background	3
<b>2</b>	<b>Surrounding Environment</b>	<b>4</b>
2.1	Study Area	4
2.2	Zoning	5
2.3	Surrounding Road Geometry	7
2.3.1	Bowen Street	8
2.3.2	Lambton Quay	8
2.3.3	Molesworth Street	9
2.3.4	Ballantrae Place	10
2.3.5	Museum Street (Private Access Road)	10
2.4	Key Intersections	11
2.4.1	Museum Street/Bowen Street/The Terrace	11
2.4.2	Ballantrae Place/Bowen Street	12
2.5	Traffic Counts	13
2.5.1	Museum Street	13
2.5.2	Ballantrae Place	13
2.6	Surrounding Cycle Path Provision	14
2.7	Public Transport Provision	15
2.8	Pedestrian Accessibility	16
2.9	Crash Analysis	16
2.9.1	Museum Street / Bowen Street / The Terrace Intersection	19
2.9.2	Ballantrae Place / Bowen Street Intersection	19
<b>3</b>	<b>New and Future Network Changes</b>	<b>21</b>
3.1	Let's Get Wellington Moving	21
3.1.1	Thorndon Quay	21
3.1.2	Hutt Road	21
3.1.3	Golden Mile	22
3.2	Central City	23
<b>4</b>	<b>Existing Site Transport Provisions</b>	<b>25</b>
4.1	Existing Site Access & Parking	25
4.1.1	Existing Vehicle Access	25
4.1.2	Existing Pedestrian and Cycle Access	27
4.1.3	Existing Cycle Parking Provision	28
4.1.4	Existing Vehicle Parking	29
<b>5</b>	<b>Proposed Development</b>	<b>30</b>
5.1	Site Access	31
5.2	Parking Provision	33
5.3	Servicing	35
5.4	Cycle Parking	36
5.5	Internal Vehicle Movements	36
5.6	Walking and Cycling Access Arrangements	36
<b>6</b>	<b>Proposed Trip Generation and Network Effects</b>	<b>37</b>
6.1	Network Effects	37

6.1.1	Ballantrae Place ADT .....	39
<b>7</b>	<b>District Plan Assessment .....</b>	<b>40</b>
<b>8</b>	<b>Recommendations and Conclusions .....</b>	<b>51</b>



# 1 Introduction

## 1.1 Background

Parliamentary Service commissioned Aurecon Ltd to prepare an Integrated Transport Assessment (ITA) Report to support the Outline Plan of Works for the 2021 Future Accommodation Strategy project (refer to Figure 1 below). This project includes:

- The construction of a new office building (MUS) west of the existing Parliament House,
- Construction of the Ballantrae Place building (BAL) for the precinct's secure deliveries,
- A reduction in off-street parking provision within the precinct from 410 parking spaces to 171 parking spaces (a parking reduction of approximately 42%). Retained parking spaces will remain as existing.
- The provision of 149 new staff cycle parks for a total on-site provision of 202 staff cycle parks. Additionally, 8 new visitor cycle parks will be provided within the precinct.
- No new parking spaces are proposed within the Precinct with the exception of mobility parking bay to be located in the MUS basement. The site will provide a total of 8 mobility parks.
- Changes to the existing visitor, staff and service access routes to, and within, the site to improve the overall safety and accessibility of the precinct.

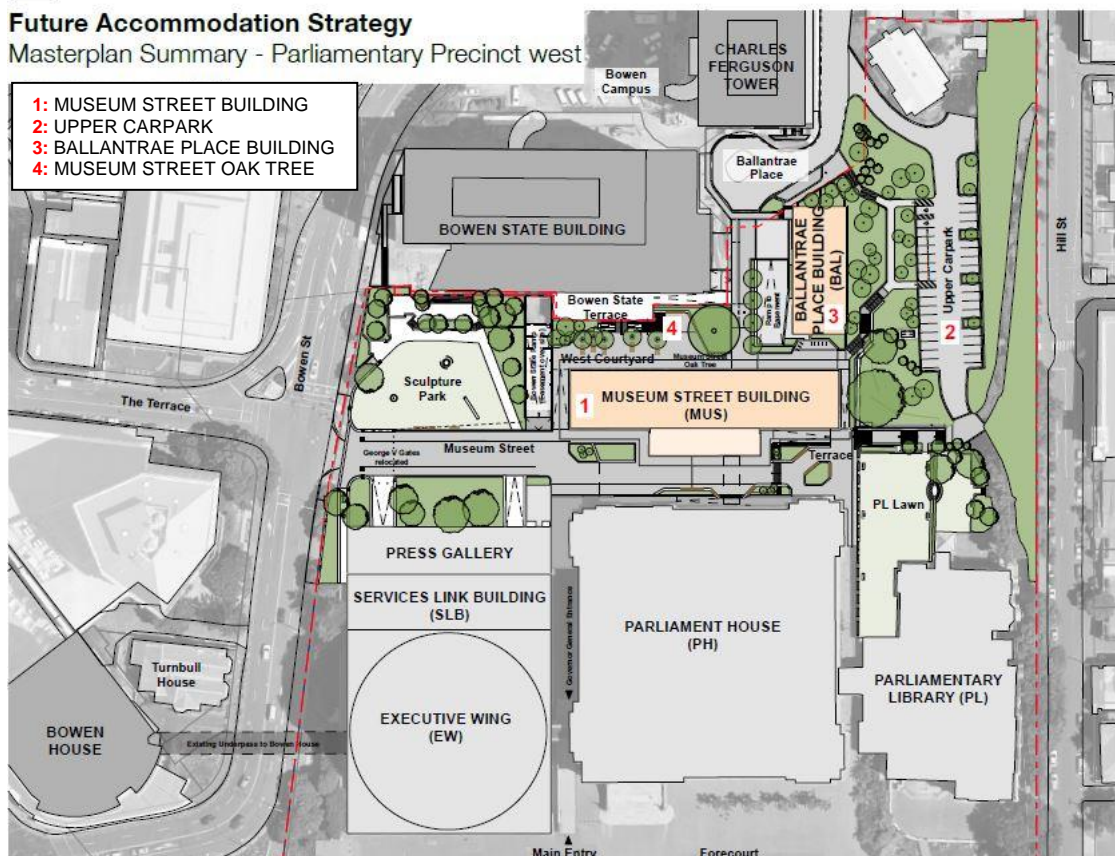

Figure 1: Parliamentary Precinct Masterplan

This report provides an assessment of the transportation effects of the proposal. It has been prepared broadly in accordance with the guidance specified in the Integrated Transport Assessment Guidelines published by the New Zealand Transport Agency. A site visit to inform this report was undertaken on the 4<sup>th</sup> of June 2021.

## 2 Surrounding Environment

### 2.1 Study Area

There are three existing buildings in Wellington that house the New Zealand Parliament – Parliament House, Parliamentary Library and the Executive Wing (also known as the Beehive).

Parliament House, Parliamentary Library and the Executive Wing form part of New Zealand's national heritage and are located within the commercial centre of Wellington City. The location of the site under consideration is defined by the approximate boundary shown in Figure 2 below.

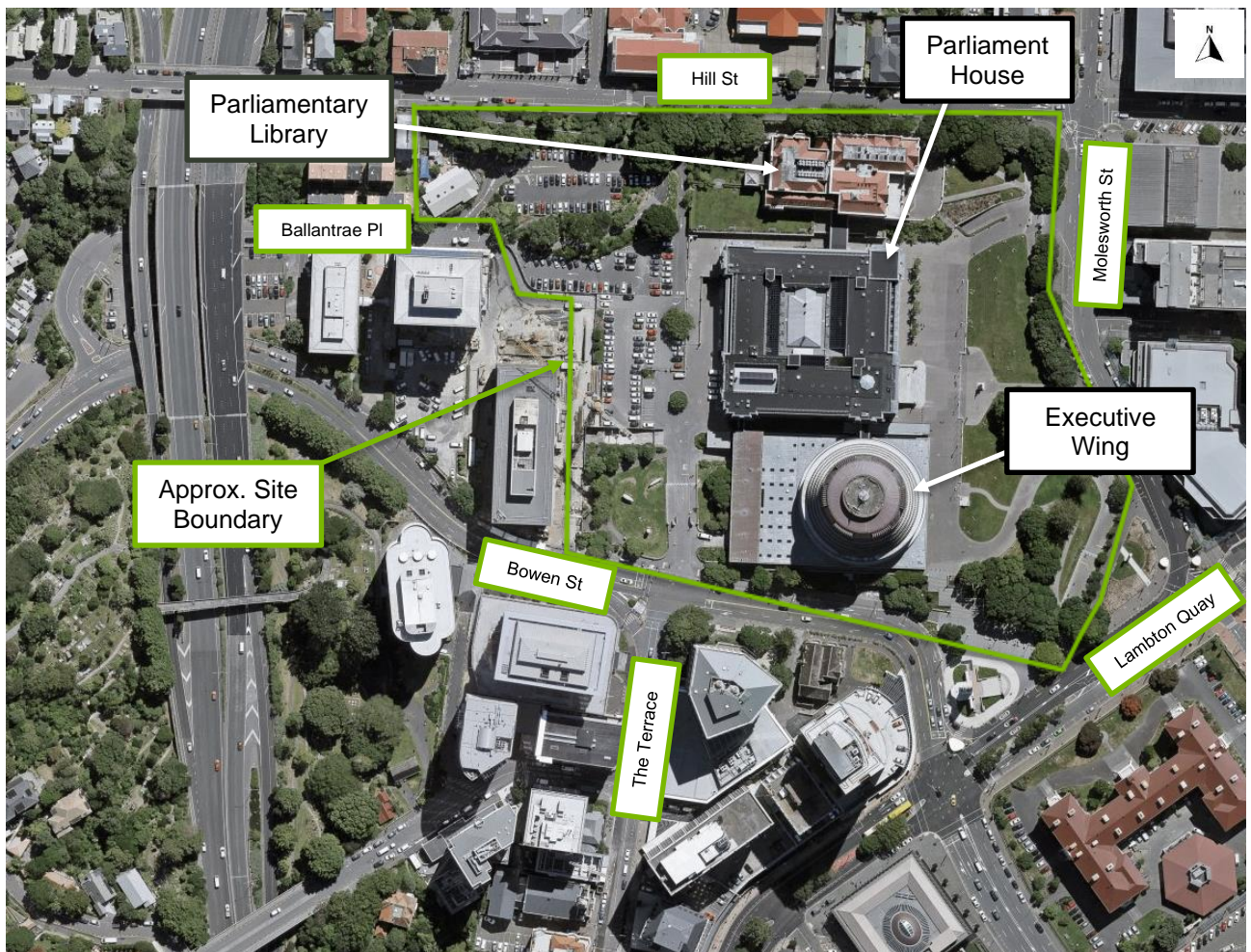

Figure 2: Site Boundary



The site is located in a highly pedestrianised area and neighbored primarily by commercial activities within the Central Area zone. Bordering the site are other key buildings to the north, east and south, including but not limited to, the National Library of New Zealand and New Zealand Law Society Library.

The Victoria University of Wellington, Pipitea Campus is located east of the site along Lambton Quay and Bunny Street and Sky Stadium is located northeast of the site. These activities are shown in Figure 3 below.

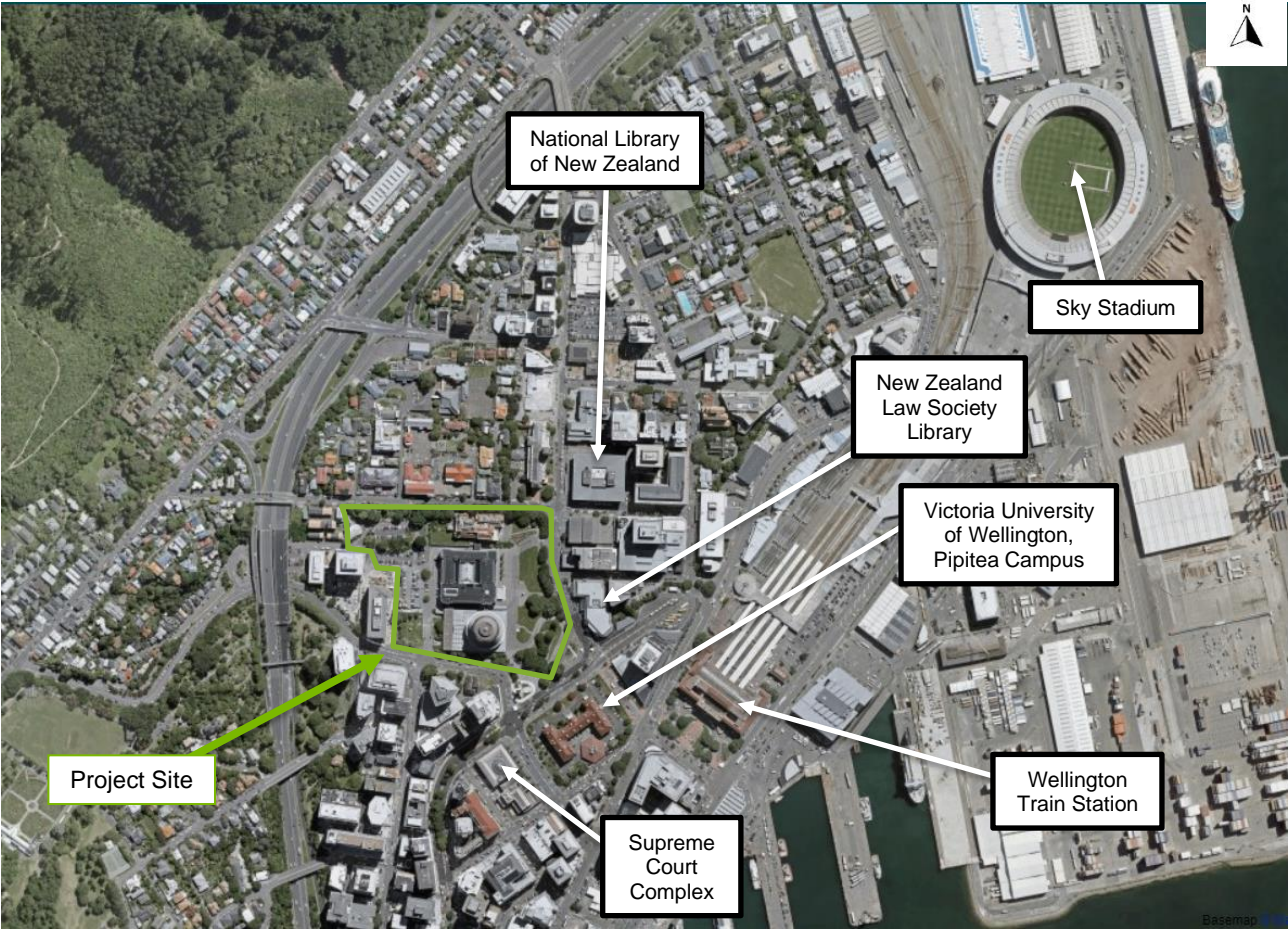

Figure 3: Surrounding Area

## 2.2 Zoning

The project site is located within the Central Area Zone as defined by the Wellington District Plan (WDP). The site is surrounded by the Central Area Zone and Outer Residential activities. The WDP describes the Central Area Zone as:

*“The Central Area is the commercial heart of Wellington City and the region, and also the nation’s seat of government. It is a vibrant mix of inner city living, entertainment, and commercial activity. It attracts arts, cultural and recreational events of local, national and international repute”.*

The zoning of the site and surrounding area is shown in Figure 4 below.

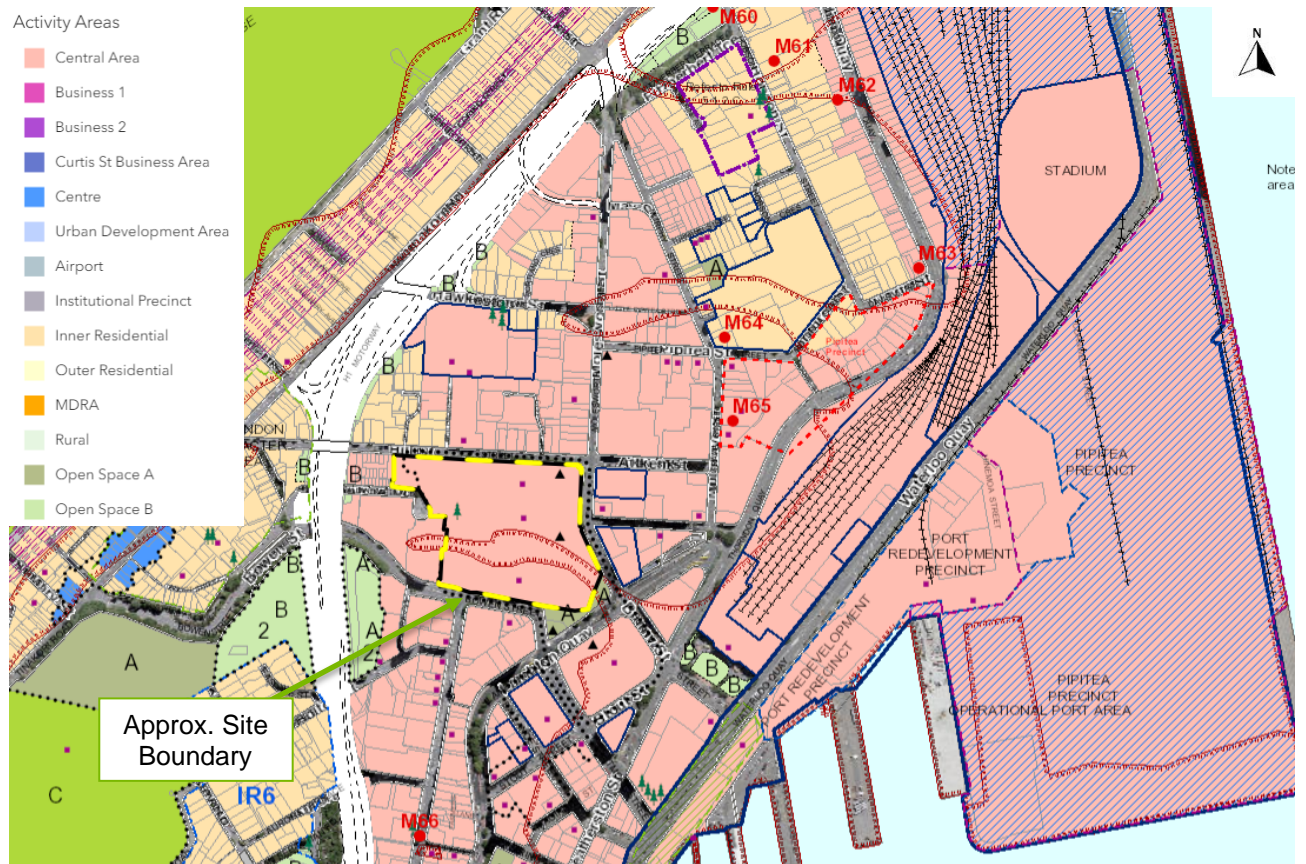

Figure 4: Site Zoning

Section 12.2.15.8 (Rules and Objectives) of the WDP States:

*“Council’s strategies on transportation and parking for the central city area **seek to manage the volume of commuter traffic, both to avoid, remedy or mitigate congestion and to improve the Central Area environment.** The strategies promote central city accessibility and the use of a variety of transport modes, including modes other than private vehicles. In particular Council seeks a high standard of public transport, pedestrian and cyclist accessibility. **One way of managing the growth of commuter traffic is by managing parking supply.** While the District Plan does not require parking to be provided for activities in the Central Area, where it is provided, a maximum level is set. This is established through a standard that sets a ratio between parking and the gross floor area of buildings. Any additional provision will generally only be considered where this can be justified for the type of activity proposed or for short-stay parking where this is appropriate for certain activities, such as shopping”*



## 2.3 Surrounding Road Geometry

The site is bordered by Bowen Street to the south, Molesworth Street and Lambton Quay to the east and Hills Street to the north. Ballantrae Place and Museum Street provide internal access to the Parliamentary Precinct. The One Network Road Classification (ONRC) and WDP road classifications of the roads surrounding the site are shown in Figure 5 and Figure 6 respectively.



Figure 5: One Network Road Classification Road Hierarchy

(source: <https://nzta.maps.arcgis.com/apps/webappviewer/index.html?id=95fad5204ad243c39d84c37701f614b0>)



Figure 6: Wellington District Plan Road Hierarchy

(Source: <https://wellington.govt.nz/-/media/your-council/plans-policies-and-bylaws/district-plan/volume03/files/v3map34.pdf?la=en&hash=FCCA40B3131FAB673B043847A962BB23E791C2DB>)

### 2.3.1 Bowen Street

Bowen Street is classified as a Principal Road in the WDP and as an Arterial Road in the ONRC. Bowen Street fronts the southern boundary of the site and provides access to Museum Street, an internal vehicle access road into the Parliamentary Precinct. The carriageway of Bowen Street is approximately 13m wide and is divided with two traffic lanes in either direction. Some P-10, paid, and coupon-based parking is provided west of the The Terrace/Bowen Street intersection. Footpaths are provided along both sides on the street east of the Mowbray Street/Bowen Street intersection. West of the Mowbray Street/Bowen Street intersection, a footpath is provided along the eastbound traffic lane only. The posted speed limit along Bowen Street is 30 km/hr.



Figure 7: Bowen Street

### 2.3.2 Lambton Quay

Lambton Quay is classified as a Collector Road in the WDP and as an Arterial Road in the ONRC. Lambton Quay fronts the south eastern boundary of the site and provides vehicular access to the Parliamentary Precinct. The carriageway of Lambton Quay is approximately 22.5m wide and accommodates two eastbound traffic lanes, one westbound traffic lane, a median island and a dedicated bus lane. On street parking is permitted along the westbound traffic lane. Wide footpaths are provided along both sides of the street. The posted speed limit along Lambton Quay is 30 km/hr.

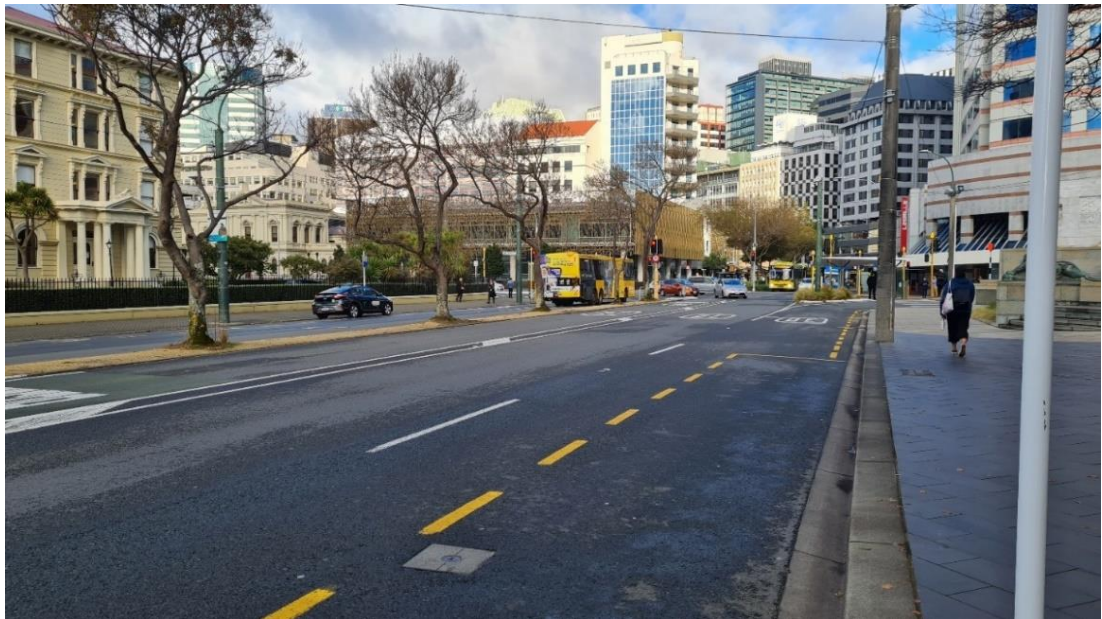

Figure 8: Lambton Quay



### 2.3.3 Molesworth Street

Molesworth Street is classified as a Collector Road in the WDP and an Arterial Road in the ONRC. Molesworth Street permits one-way movements only (northbound only) and fronts the eastern boundary of the site. The carriageway of Molesworth Street is approximately 14m wide with two northbound traffic lanes. Paid/coupon-based parking is available on both sides of the road. Footpaths are also provided along both sides of the street. The road has a posted speed limit of 50 km/hr.

A formal sheltered bus stop (bus stop 5111) for public buses is located close to the Lambton Quay/Molesworth Street intersection. Further north, a tour bus parking bay is provided for tour groups visiting the Parliamentary Precinct. Vehicle egress movements only (left turns) from the Parliamentary Precinct are permitted onto Molesworth Street.



Figure 9: Molesworth Street

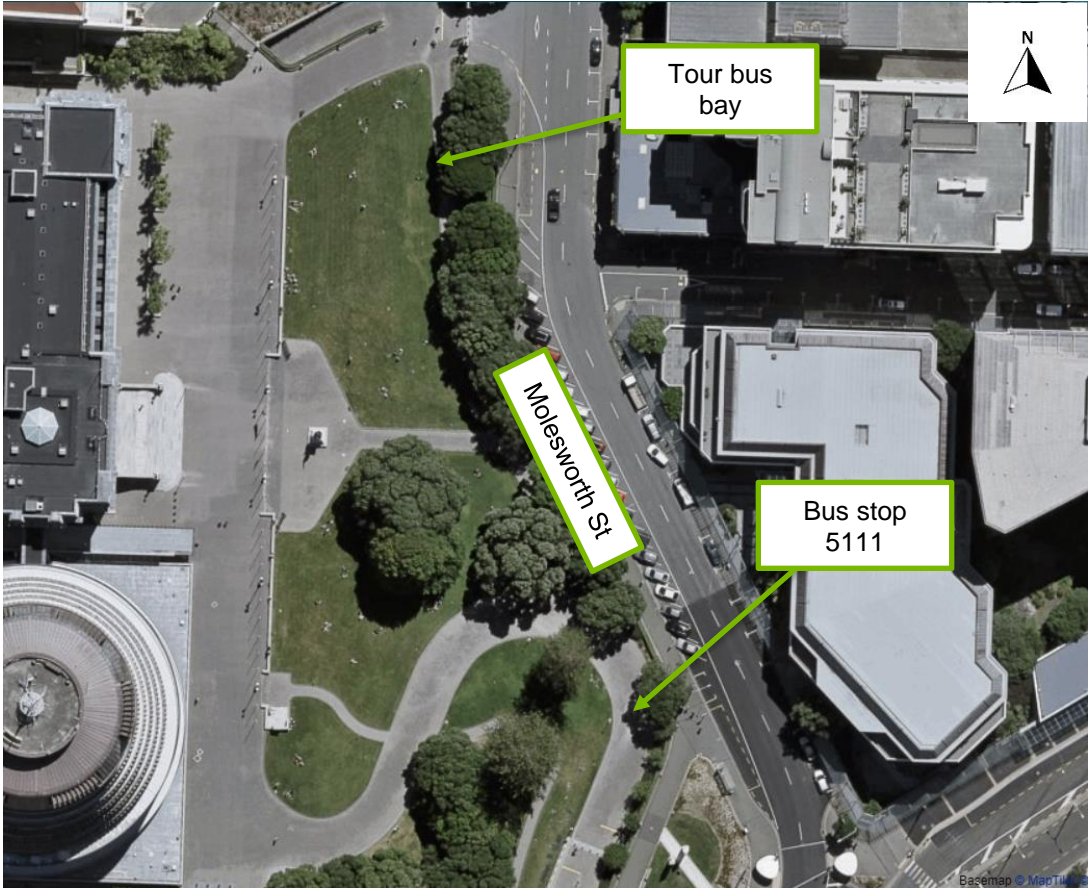

Figure 10: Molesworth Street



### 2.3.4 Ballantrae Place

Ballantrae Place is unclassified in the WDP and is classified as a Secondary Collector Road in the ONRC. Ballantrae Place provides vehicle access to the Parliamentary Precinct, the Ministry for Primary Industries and Defence House. The carriageway of Ballantrae Place is approximately 9m wide and is divided into one traffic lane in either direction. Paid parking is provided along both sides of Ballantrae Place. Footpaths are not provided along either side of the street. The road has a legal speed limit of 50 km/hr.



Figure 11: Ballantrae Place

### 2.3.5 Museum Street (Private Access Road)

Museum Street is unclassified in the WDP and classified as an 'unknown road' in the ONRC. Museum Street is a private access road and provides internal access to the Parliamentary Precinct. The carriageway of Museum Street is approximately 7m wide. Footpaths are provided along both sides of the road. Museum Street has a speed limit of 50 km/hr.



Figure 12: Museum Street



## 2.4 Key Intersections

### 2.4.1 Museum Street/Bowen Street/The Terrace

The Museum Street/Bowen Street/The Terrace intersection is a signalised intersection. Signalised aspects controlling movements into and from Museum Street are not provided.

Access to Museum Street into the project site is available via left turn movements from Bowen Street (eastbound) and right turn movements from Bowen Street (westbound). Through movements to/from Museum Street from/to The Terrace are not permitted. Signalised crossing movements for pedestrians across Bowen Street and The Terrace are provided.

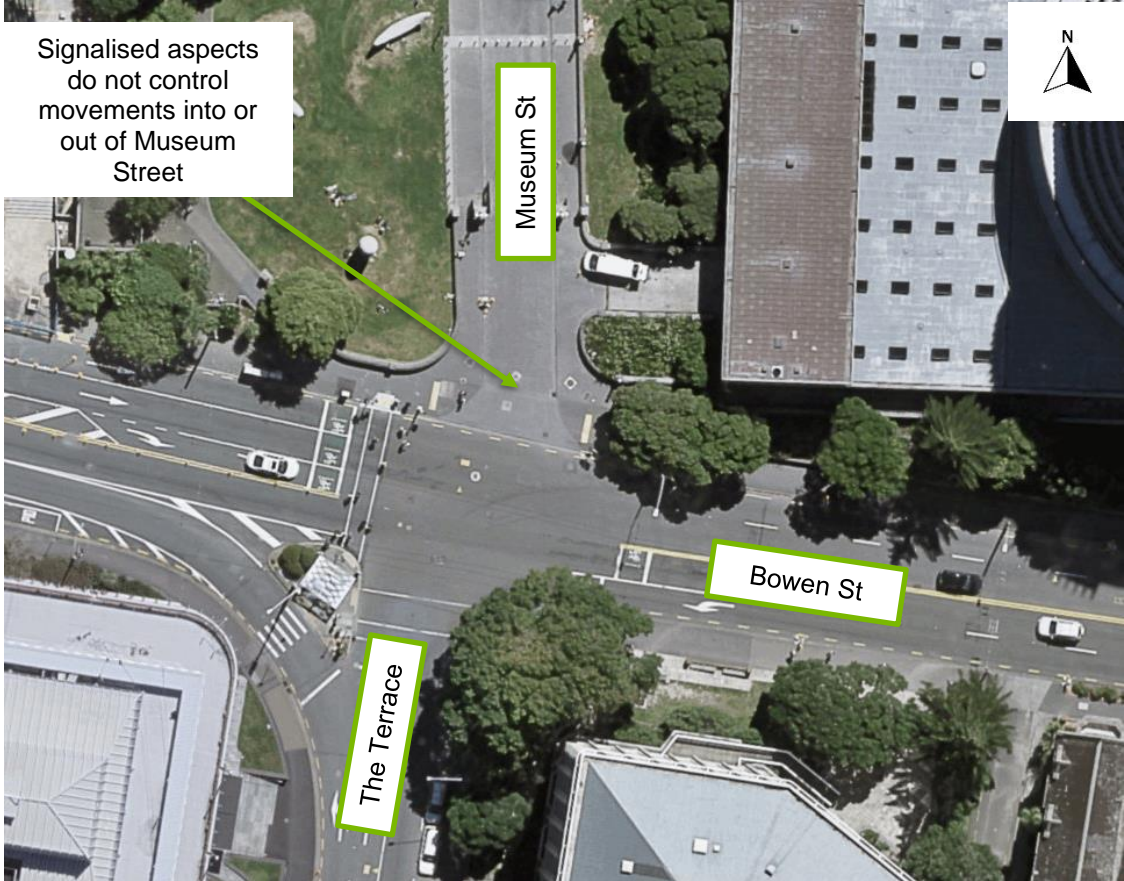

Figure 13: Museum Street/Bowen Street/The Terrace

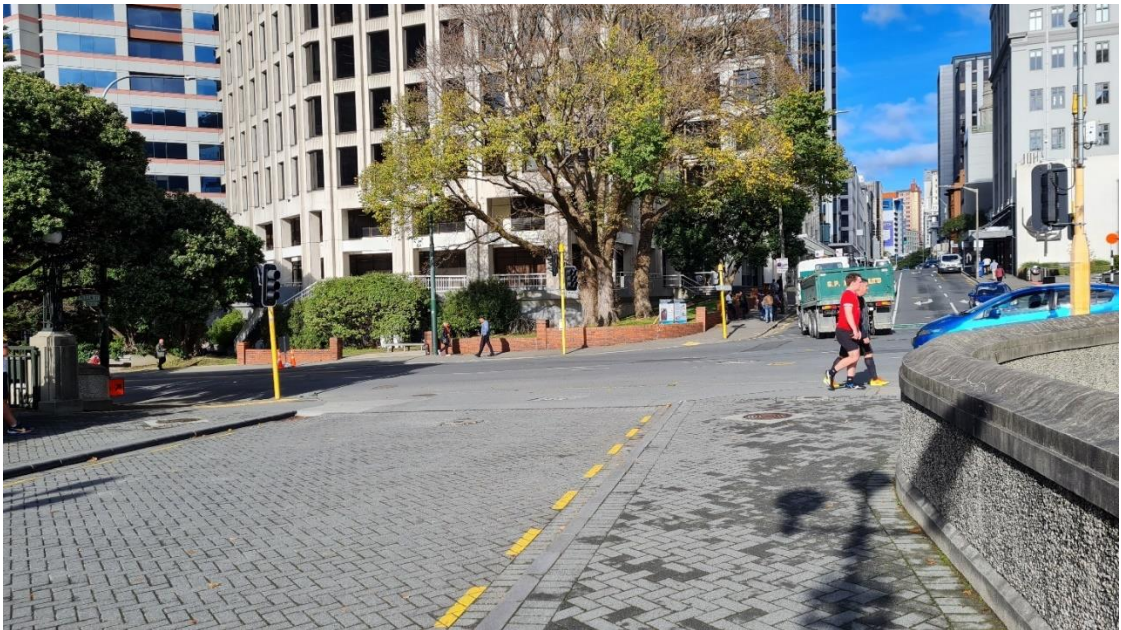

Figure 14: Museum Street/Bowen Street/The Terrace Intersection (perspective from Museum Street)



### 2.4.2 Ballantrae Place/Bowen Street

Ballantrae Place/Bowen Street is a T-intersection. Bowen Street curves where it meets Ballantrae Place. A right turn bay removes vehicles turning right onto Ballantrae Place from through traffic on Bowen Street. This is a non-signalised intersection where all movements are permitted.



Figure 15: Ballantrae Place/Bowen Street



Figure 16: Ballantrae Place/Bowen Street (perspective from Bowen Street)

## 2.5 Traffic Counts

Entry and egress traffic counts were undertaken at the Museum Street/Bowen Street/The Terrace intersection and Bowen Street/Ballantrae Place intersection on Wednesday 9th June 2021. Focus was placed on observing vehicle movements into/out of Museum Street and Ballantrae Place. Traffic volumes and other key observations from the site visit are provided in Appendix D for reference.

### 2.5.1 Museum Street

Traffic counts into/from Museum Street and observations of the Museum Street/Bowen Street/The Terrace intersection indicate that:

- Vehicles travelling into/from Museum Street from/to The Terrace regularly undertake unsignalised through movements across the intersection. This occurs amongst other conflicting signalised movements.
- Engineers undertaking the traffic counts observed that pedestrians appeared to be unaware of the frequent vehicle entry and egress movements to/from Museum Street. This resulted in some vehicles turning into Museum Street, having to stop in the middle of the intersection to wait for crossing pedestrians or vice versa.
- Right turn entry movements from Bowen Street to Museum Street increases queuing along the Bowen Street westbound through lane (refer to 8:30am 15-minute interval in Table 7 of Appendix D). This increases congestion and delays for westbound through movements along Bowen Street.
- Reducing vehicle entry and egress movements into/from the Parliamentary Precinct via Museum Street would reduce conflicting vehicle movements within the intersection and improve the safety of cyclists and pedestrians operating in vicinity of the site.

### 2.5.2 Ballantrae Place

- Waiting times of less than 30 seconds were observed for right turn movements from Bowen Street onto Ballantrae Place.
- Less than minor congestion along the westbound through lane along Bowen Street was observed.
- Roadworks were being undertaken along Bowen Street in vicinity of the Parliamentary Precinct at the time of the traffic counts. Due to ongoing roadworks, a temporary bus stop has been placed near the Ballantrae Place/Bowen Street intersection and road stoppages occurred during the traffic counts. This impacted traffic movements and observed queue lengths, particularly regarding left turn entry movements into Ballantrae Place. It is anticipated that once roadworks are completed, observed queue lengths will be reduced.
- Traffic counters observed U-turn movements being undertaken in vicinity of the Bowen Street/Ballantrae Place intersection. The majority of U-turn movements were undertaken at Location 1 along Bowen Street as shown in Figure 17 below. It is unclear if the frequency of these U-turn movements can be attributed to the ongoing roadworks. U-turn movements at Location 1 and Location 3 (refer to Figure 17) poses a risk to other vehicles/cyclists operating in vicinity of the intersection, due to the curvature and grade of Bowen Street.
- It does not appear that these U-turn movements are necessary to accommodate access to buildings or services in vicinity of the intersection. U-turn movements may therefore be occurring due to the ongoing roadworks, or drivers rerouting to access a vacant parking space along Bowen Street. It is recommended that monitoring of this intersection is undertaken post-roadworks by Wellington City Council to determine if U-turn restrictions along Bowen Street are required to improve the safety and functionality of the intersection.



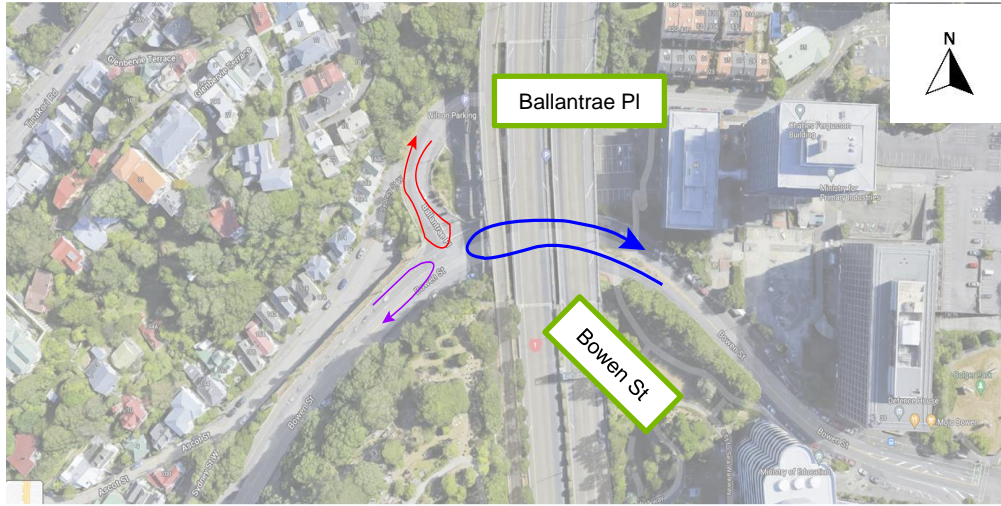

Figure 17: U-turn movements observed

## 2.6 Surrounding Cycle Path Provision

Existing and proposed cycle infrastructure in the area surrounding the Parliamentary Precinct is shown in Figure 18 below. The extent of cycleways and shared paths in the surrounding area provides good accessibility to the site from the south and east via bicycle. Cycle paths are provided to the north of the site, but gaps in the network reduce accessibility.

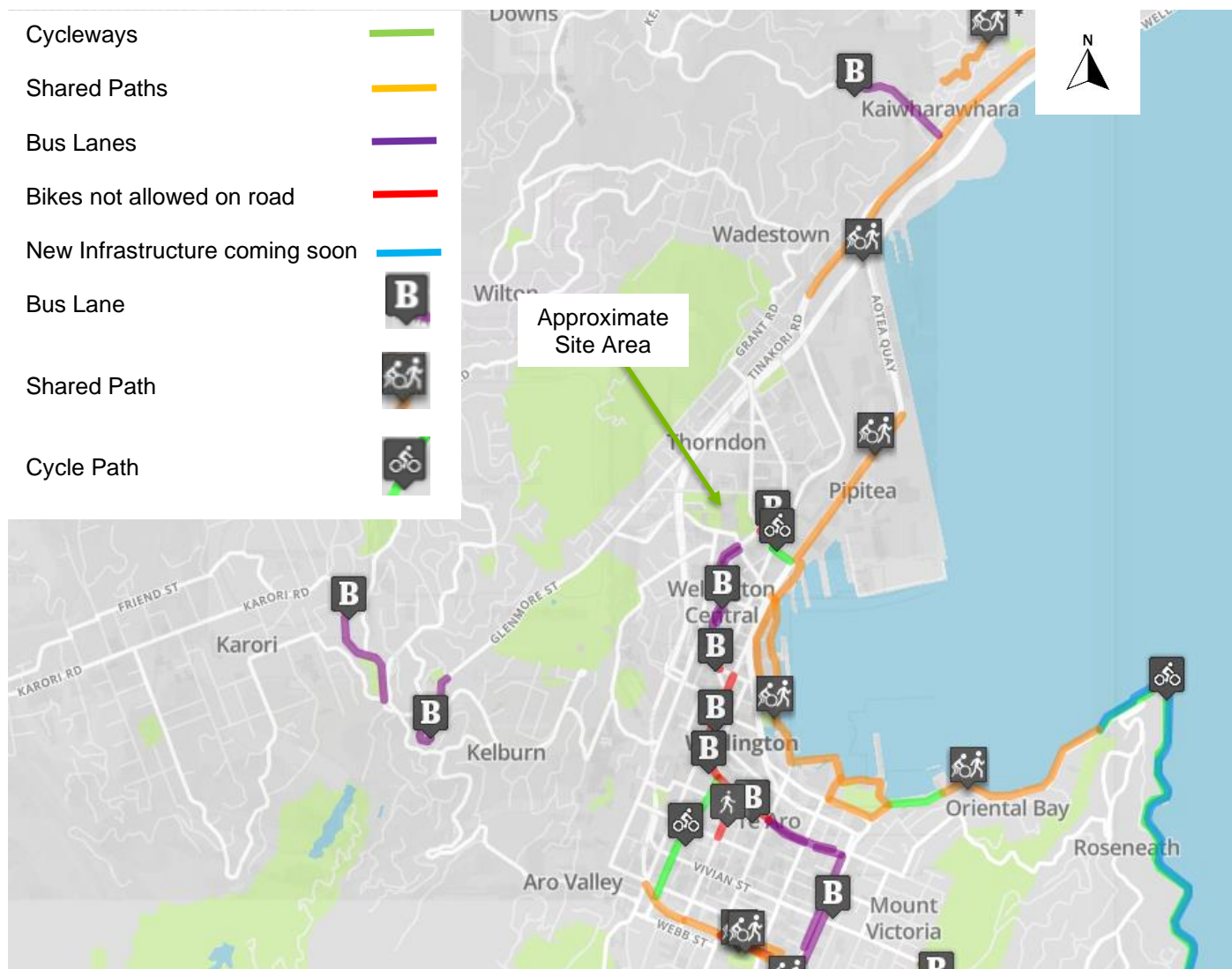

Figure 18: Surrounding Cycle Infrastructure

## 2.7 Public Transport Provision

The Parliamentary Precinct is highly accessible via public transport. Bus stops are provided along Hill Street, Bowen Street, The Terrace, Molesworth Street and Lambton Quay as shown in Figure 19 below.

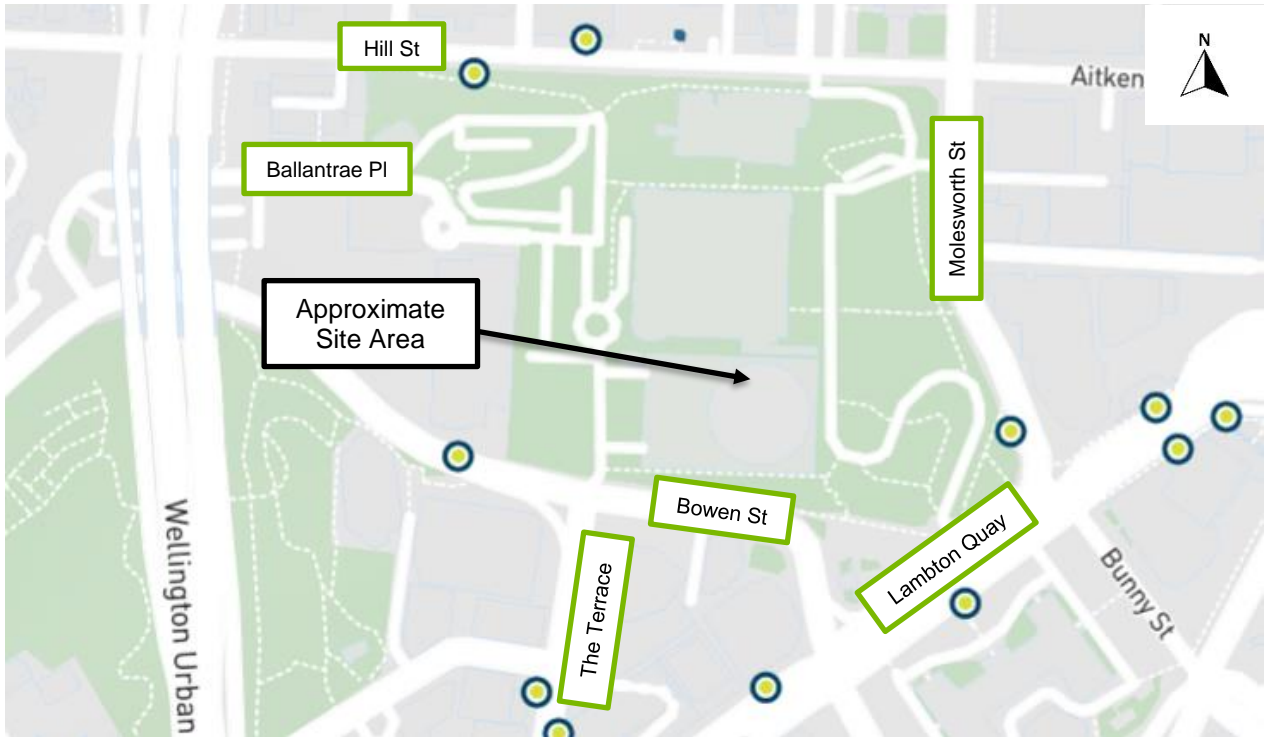

Figure 19: Bus Stops in Vicinity of the Site

Stops in vicinity of the site are serviced by several high frequency bus routes (10 to 15-minute intervals) including but not limited to; Route 2, Route 21, Route 22, Route 1 and Route 3. Route 14 and Route 18 operate on 30 to 60-minute intervals as shown in Figure 20 below. The site is also highly accessible via train (Johnsonville Line, Kapiti Line, Hutt Valley Line and Wairarapa Line) due to its proximity to the Wellington Station (550m). The Lambton Quay Ferry Terminal is also located approximately 750m east of the site.

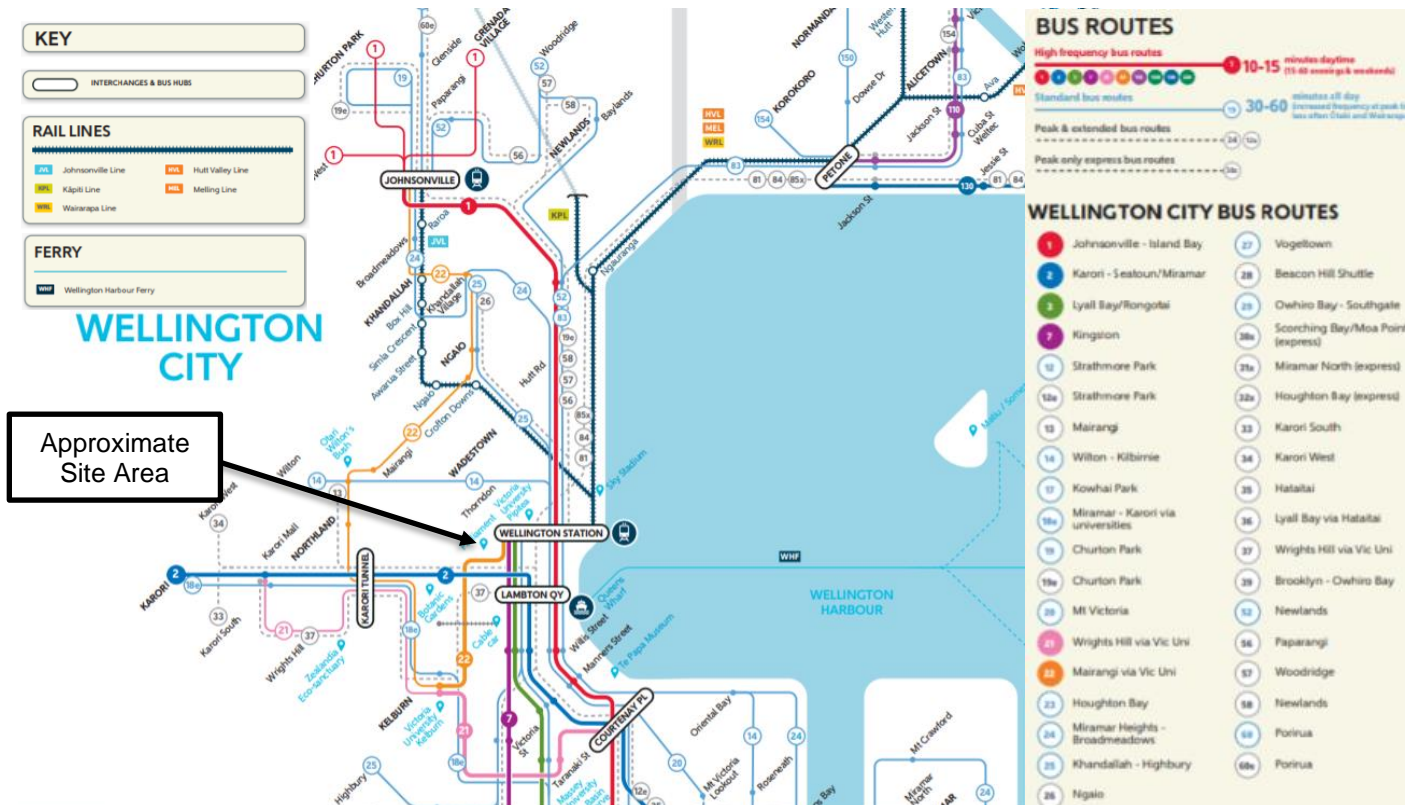

Figure 20: Public Transport Services (Wellington City)



## 2.8 Pedestrian Accessibility

Footpaths are consistently provided in the area surrounding the Parliamentary Precinct. Footpath width varies between 1.5m – 4m. Protected pedestrian crossing movements are provided at signalised intersections surrounding the site, with shelters/covered areas provided along some sections of the footpaths and crossing points.



Figure 21: Footpaths and Crossing Points

## 2.9 Crash Analysis

The Crash Analysis System (CAS) database records reported crash details nationwide dating back to 1980. CAS data was obtained for the immediate vicinity of the site for the previous 10 years. It is important to note that the recorded crashes only include those reported to the New Zealand Police, therefore other minor events may be excluded from the database.

The data shows a total of 98 reported crashes on roads in the immediate vicinity of the project site in the 10-year period between 2011 and 2020. A description report, detailing these crashes is attached in Appendix A. The area shown in Figure 22 includes the extent of the studied area.

*\*Note that crashes along the State Highway 1 overbridge have been excluded.*

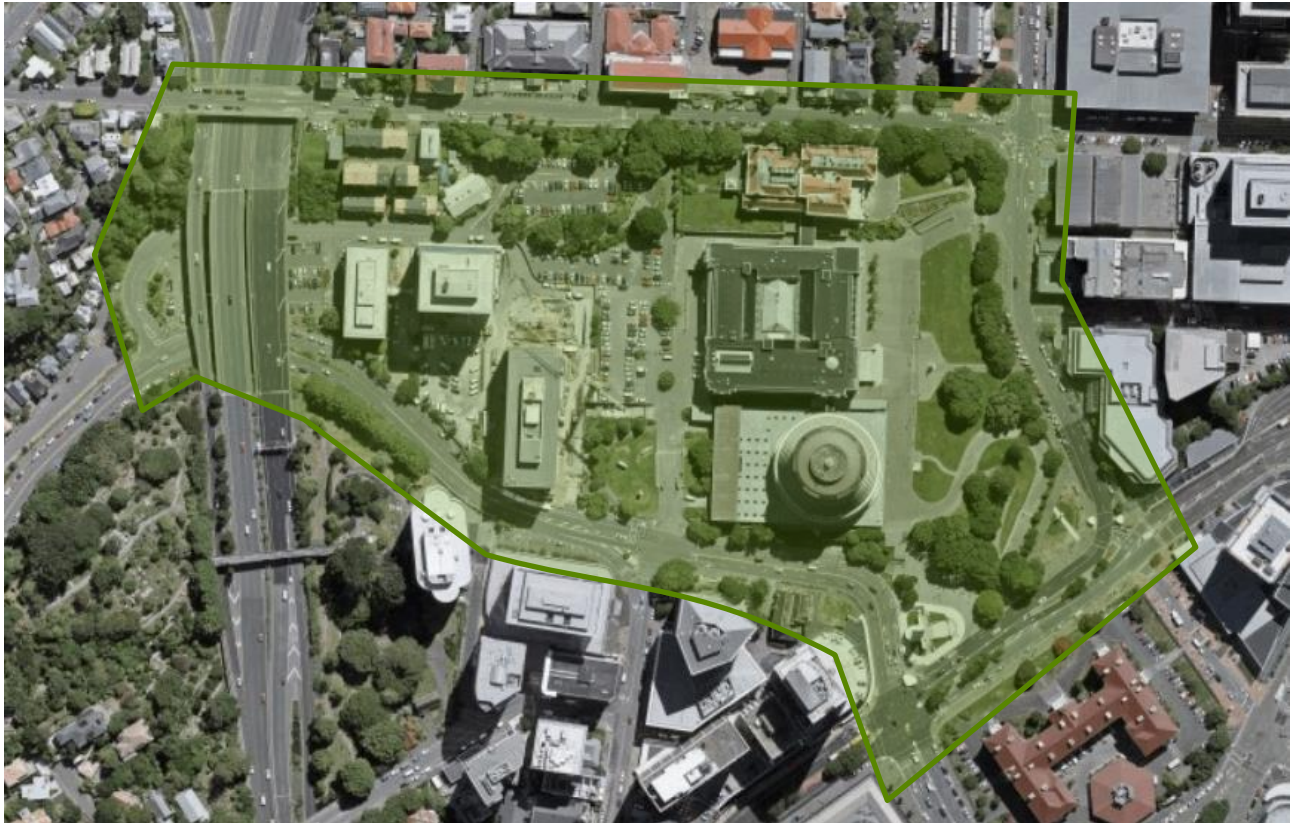

**Figure 22: CAS Study Area**

Figure 23 below provides a summary of the reported crashes in the period under consideration.

### Reported Crashes (2011 - 2020)

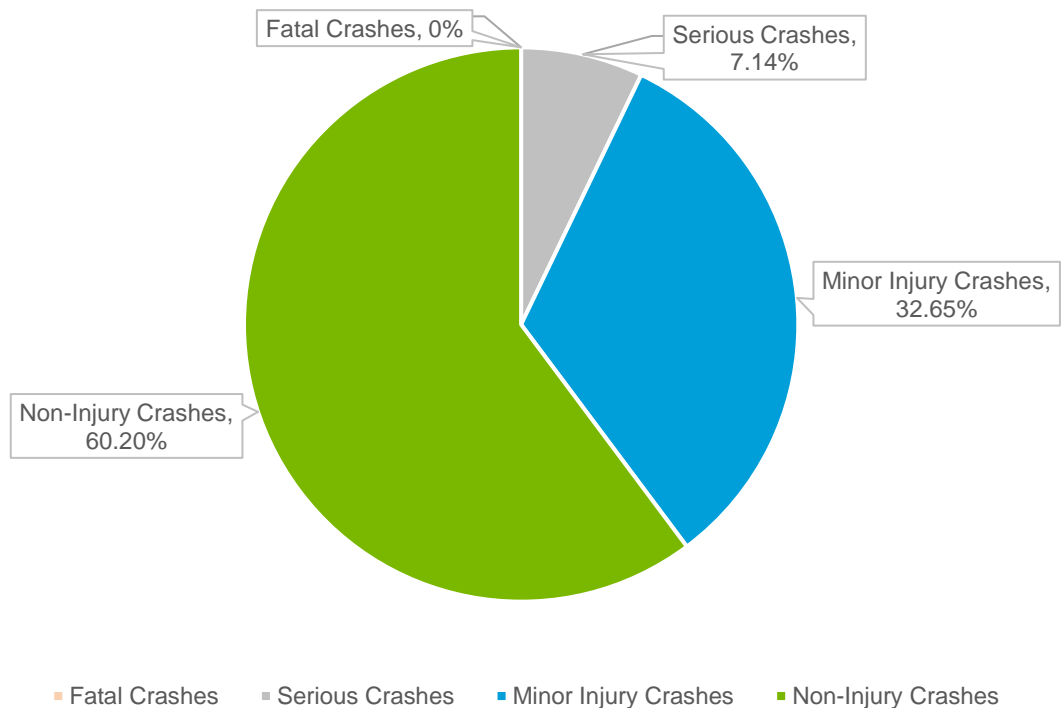

**Figure 23: Crash Type (2011 - 2020)**

A summary of the total reported crashes per year is provided in Table 1 and Table 2 below:

**Table 1: Crash Summary 2011 - 2015**

Year	Crash Severity				Subtotal
	Fatal	Serious	Minor	Non-injury	
2011	0	0	2	3	5
2012	0	2	4	4	10
2013	0	1	6	7	14
2014	0	0	3	8	11
2015	0	1	5	9	15
<b>Subtotal</b>	<b>0</b>	<b>4</b>	<b>20</b>	<b>31</b>	<b>55</b>

**Table 2: Crash Summary 2016-2020**

Year	Crash Severity				Subtotal
	Fatal	Serious	Minor	Non-injury	
2016	0	1	1	8	10
2017	0	1	2	5	8
2018	0	1	4	1	6
2019	0	0	4	9	13
2020	0	0	1	5	6
<b>Subtotal</b>	<b>0</b>	<b>3</b>	<b>12</b>	<b>28</b>	<b>43</b>

It is noted that the total number of crashes have decreased in the last 5-year period (2016 – 2020) when compared to the previous 5-year period (2011 – 2015). There has also been a decrease across serious crashes, minor crashes and non-injury crashes in the most recent 5-year period.

The type of crashes which occurred over the last ten-year period is shown in Figure 24 below.

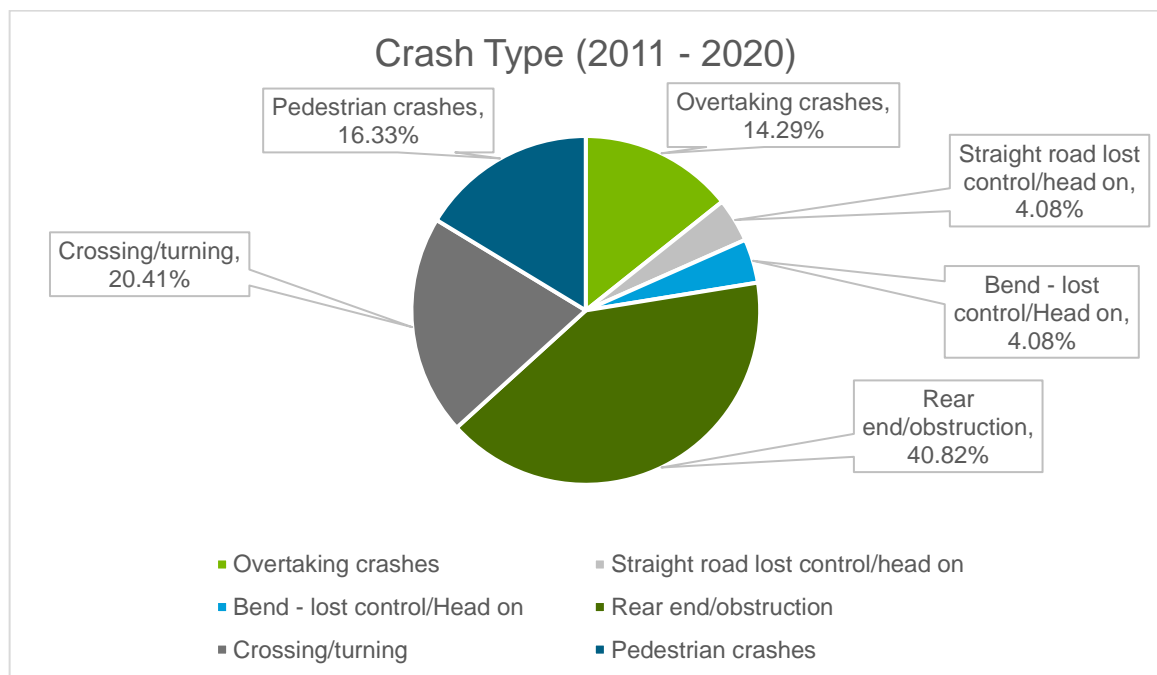

**Figure 24: Crash Type (2011 - 2020)**



The most reported attributing crash factors were poor observation, incorrect lanes/positions and failure to give way or stop. The majority of crashes occurred at intersections (89.80%) with the remainder (10.20%) being midblock collisions.

With consideration to vulnerable users, 14 crashes (14.28%) involved cyclists and 16 crashes (16.33%) involved pedestrians. Of the crashes noted, three crashes involved a cyclist which resulted in serious injury, and one involved a pedestrian resulting in serious injury. The details of these incidents are provided below:

- On the 19<sup>th</sup> of June 2017 at 8:46am, a 57-year-old eastbound cyclist undertaking a turning movement on Bowen Street was hit by an eastbound car also turning along Bowen Street. The driver failed to check/notice the cyclist turning in the opposite direction, resulting in a serious crash.
- On the 9<sup>th</sup> of July 2013 at 7:55am a 44-year-old cyclist travelling along Bowen Street was hit by an opening truck door. The vehicle was incorrectly parked, and the driver failed to check/notice the cyclist before opening the door, resulting in a serious crash.
- On the 23<sup>rd</sup> of April 2012 at 4:45pm a 45-year-old southbound cyclist travelling along Lambton Quay was hit by a vehicle turning at a right angle to the cyclist. The vehicle failed to stop at the red light, resulting in a serious crash.
- On the 16<sup>th</sup> of October 2015 at 3:30pm a 15-year-old pedestrian crossing the road from the right was hit by a northbound moped travelling along Lambton Quay. The moped failed to check/notice the pedestrian potentially due to the curve along the road.

### **2.9.1 Museum Street / Bowen Street / The Terrace Intersection**

Over the previous 10-year period, 24 of the reported crashes (in the area under consideration) occurred in vicinity of the Museum Street/Bowen Street/The Terrace intersection (<100m). Two collisions which occurred at this intersection involved heavy vehicles (trucks) and vulnerable users (pedestrians or cyclists) as detailed below:

- On the 9<sup>th</sup> of July 2013 at 7:55am a 44-year-old cyclist travelling along Bowen Street was hit by an opening truck door. The vehicle was incorrectly parked, and the driver failed to check/notice the cyclist before opening the door, resulting in a serious crash.
- On the 27<sup>th</sup> of November 2014 at 8:16am a 31-year-old eastbound cyclist travelling along Bowen Street was hit by a truck turning right. The truck failed to give way to the through moving cyclist, resulting in a minor injury crash.

Users of the site have reported a high frequency of near misses between vehicles turning into Museum Street and pedestrians/cyclists crossing Museum Street. During the undertaken site visit, a near miss between a cyclist crossing Museum Street and an entering service vehicle (turning right into Museum Street from Bowen Street) was witnessed.

### **2.9.2 Ballantrae Place / Bowen Street Intersection**

Over the previous 10-year period, 4 crashes occurred in vicinity of the Bowen Street/Ballantrae Place intersection (<100m).

Two collisions involved vehicles turning right from Bowen Street onto Ballantrae Place:

- On the 20<sup>th</sup> of June 2012 at 6:45am a truck turning right from Bowen Street onto Ballantrae Place hit a northbound cyclist travelling on Bowen Street. The truck failed to give way to the through moving cyclist, resulting in a minor injury crash.
- On the 14<sup>th</sup> of May 2012 at 9:10am a vehicle turning right from Bowen Street onto Ballantrae Place hit a northbound vehicle travelling on Bowen Street. The truck failed to give way to the through moving vehicle, resulting in a non-injury crash.

Two collisions occurred due to vehicles undertaking U-turn movements along Bowen Street in vicinity of the intersection:

- On the 20<sup>th</sup> of September 2016 at 4:08pm a southbound vehicle travelling on Bowen Street hit a U-turning SUV travelling in the same direction on Bowen Street. The SUV failed to check/notice the other vehicle, resulting in a non-injury crash.
- On the 17<sup>th</sup> of March 2016 at 2:40pm a westbound vehicle travelling on Bowen Street hit a U-turning motorcycle travelling in the same direction on Bowen Street. The motorcycle failed to check/notice the other vehicle, resulting in a minor injury crash.

Overall, the level of reported crashes at the Bowen Street/Ballantrae Place intersection does not indicate systematic safety or functionality issues. However, it is recommended that monitoring of U-turn movements along Bowen Street post-roadworks are undertaken by Wellington City Council to determine if restrictions on U-turn movements would improve the safety of this intersection.

For anticipated safety and functionality impacts of the proposed works on the intersections of Bowen Street/Museum Street/The Terrace and Bowen Street/Ballantrae Place, refer to Section 6.1 of this report.

## 3 New and Future Network Changes

### 3.1 Let's Get Wellington Moving

The Let's Get Wellington Moving project is a joint initiative with Wellington City Council, Greater Wellington Regional Council and Waka Kotahi, aimed at improving the Wellington transport system. Proposed works relevant to the project site are detailed in the following sections.

#### 3.1.1 Thorndon Quay

Proposed works along Thorndon Quay include part-time bus lanes in both directions and an extension of the two-way cycle path from Hutt Road to the bus interchange at Mulgrave Street. Bus priority will be provided at Mulgrave Street. Walking and cycling facilities along Thorndon Quay will be improved to accommodate future growth in the numbers of people using public transport and active modes. Safety will be improved through the removal of angle parking, the provision of a dedicated cycle path and improved pedestrian crossings. Proposed works will occur over two stages, with initial works starting in late 2021.



Figure 25: Thorndon Quay

#### 3.1.2 Hutt Road

Proposed works along Hutt Road includes the provision of part-time bus lanes in both directions and bus priority at the Ngauranga/Jarden Mile intersection. Providing bus lanes in both directions is expected to improve bus travel times and reliability during peak hours, making buses a more attractive travel option.

The shared path between the Ngauranga/Jarden Mile intersection and Caltex will also be upgraded to a two-way cycle path and dedicated footpath. The new paths will connect with the existing paths on Hutt Road and the bike path will connect with the proposed new cycle path on Thorndon Quay. There will also be a future connection to Te Ara Tupua.

To reduce risks to pedestrians and cyclists due to vehicles turning right across traffic on Hutt Road, between Aotea Quay and Ngauranga, a raised central median to prevent right turns along this section of Hutt Road is also proposed. A proposed new roundabout on Aotea Quay is expected to reduce the amount of traffic on Hutt Road by providing alternative access to the Kaiwharawhara ferry terminal from State Highway 1.



Figure 26: Hutt Road

### 3.1.3 Golden Mile

The Golden Mile, running along Lambton Quay, Willis Street, Manners Street and Courtenay Place is a highly pedestrianised area and Wellington’s main bus corridor. Three concept design options are currently under consideration to support expected future growth and to increase the reliability and attractiveness of public transport along Golden Mile:

1. “Streamline” takes some general traffic off the Golden Mile to help make buses more reliable and creates new space for pedestrians.
2. “Prioritise” goes further by removing all general traffic and allocating extra space for bus lanes and pedestrians.
3. “Transform” changes the road layout to increase pedestrian space (75% more), new bus lanes and, in some places, dedicated areas for people on bikes and scooters.

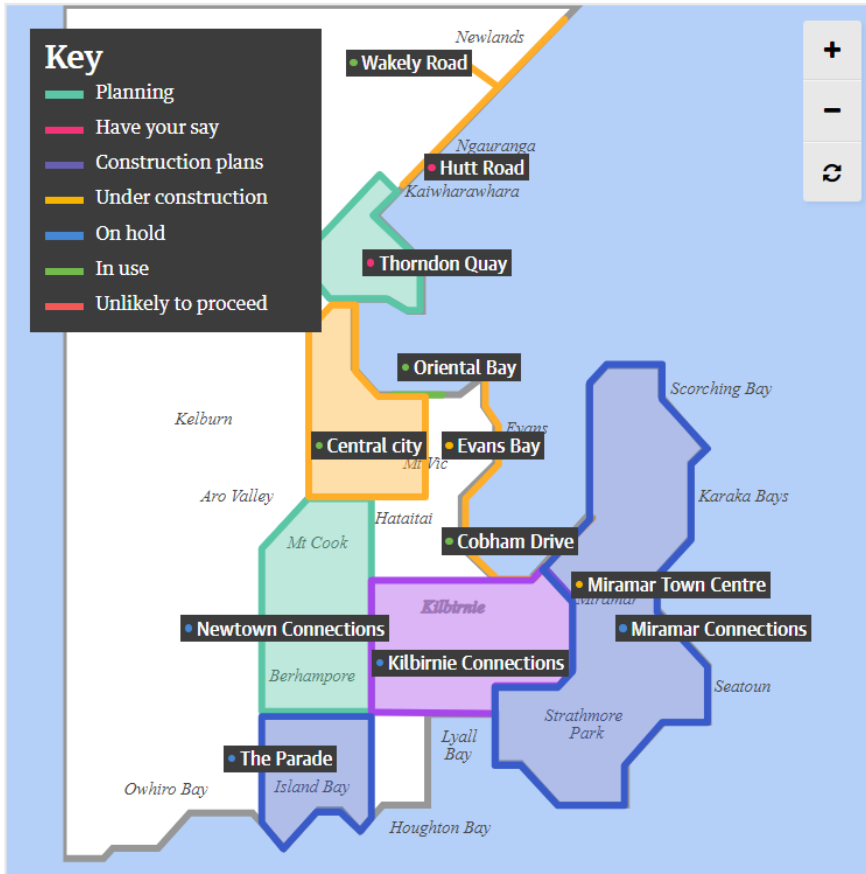

Figure 27: Golden Mile

Selection of the preferred option for this project was still in progress at the time of writing this report.



### 3.2 Central City



Other works currently under construction or recently completed in the Central City are detailed below

**Bunny Street:** Part of Bunny Street, adjacent to Victoria University of Wellington's business and law schools, was recently converted to a shared zone. Cyclists can now ride both ways between Lambton Quay and Featherston Street.

**Featherston Street:** The existing city-bound bike lane on Featherston Street has been extended to create a continuous lane from Bunny Street to Ballance Street.

**Grey Street:** A 1m-wide bike lane on part of Grey Street has recently been completed. Cyclists can now ride both ways between Featherston Street and Customhouse

Quay. A covered bike parking area along Grey Street has also been provided, with space for 59 bikes in a Dutch two-tier rack.

Figure 28: Central City Works

**Kent and Cambridge Terrace:** Walking and biking connections near the southern end of Kent Terrace and Cambridge Terrace have been made safer and easier as shown in Figure 29 below.

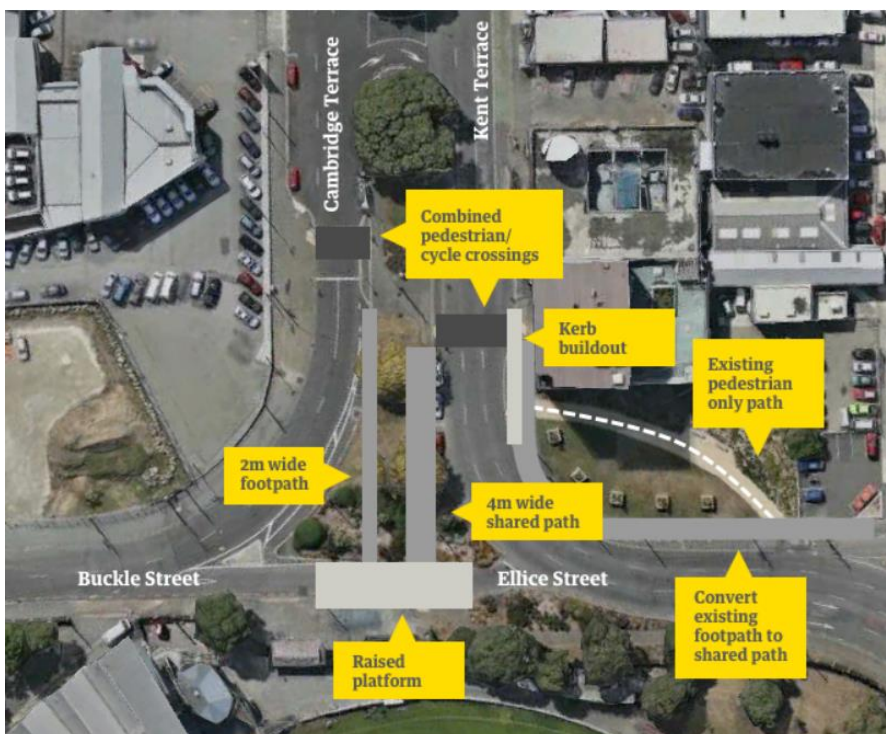

Figure 29: Kent and Cambridge Terrace Improvements

**Lower Cuba Street:** Cyclists can now cycle both ways in the shared zone on lower Cuba Street, between Wakefield Street and Manners Street. Vehicle traffic has been restricted to one-way travel from Manners Street down to Wakefield Street.

**Post Office Square:** The crossing at Jervois Quay between Post Office Square and Queens Wharf has been improved for pedestrian and cyclist movements. A direct biking connection to the waterfront has also been provided.

**Rugby Street:** An uphill bike lane has been installed on Rugby Street at the Basin Reserve roundabout. This protected lane provides a safer connection for people riding from Adelaide Road up to Tasman Street.

## 4 Existing Site Transport Provisions

The boundary of the project site is shown in Figure 30 below.

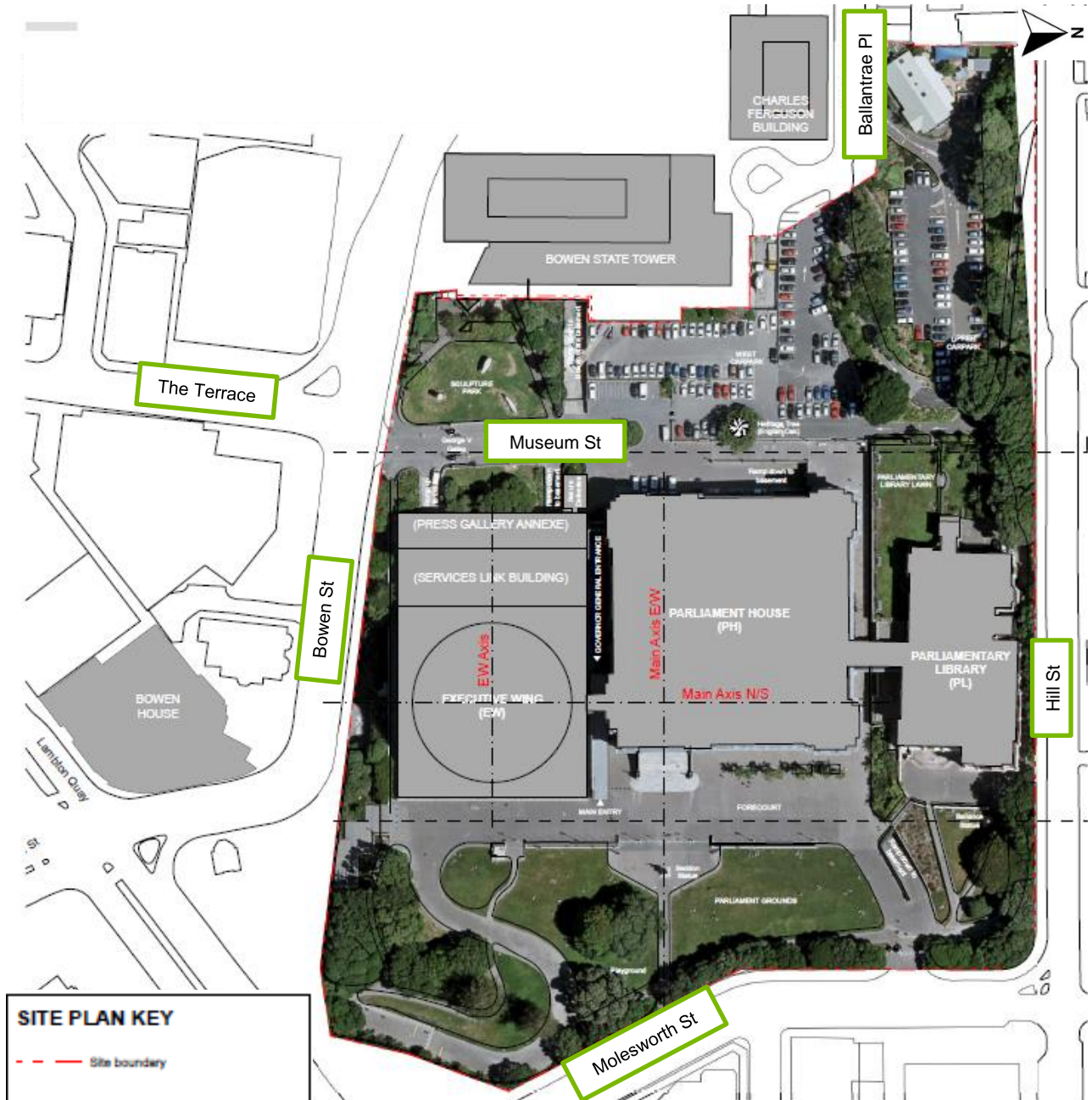

Figure 30: Existing Site Plan

### 4.1 Existing Site Access & Parking

#### 4.1.1 Existing Vehicle Access

Currently, visitor vehicles, taxis and some VIP vehicles access the site via Lambton Quay, and exit via Molesworth Street (Refer to green line in Figure 31). Staff predominantly enter the site via Ballantrae Place and Museum Street and exit the site via Ballantrae Place, Molesworth Street and Museum Street.

Access and egress movements to/from the site via Ballantrae Place, Museum Street, Molesworth Street and Lambton Quay are gate and bollard controlled. Basement vehicle routes connect the Executive Wing,





Parliamentary House/Parliamentary Library (PH/PL) and the Forecourt area. These movements are shown in Figure 31 below (refer to pink lines).

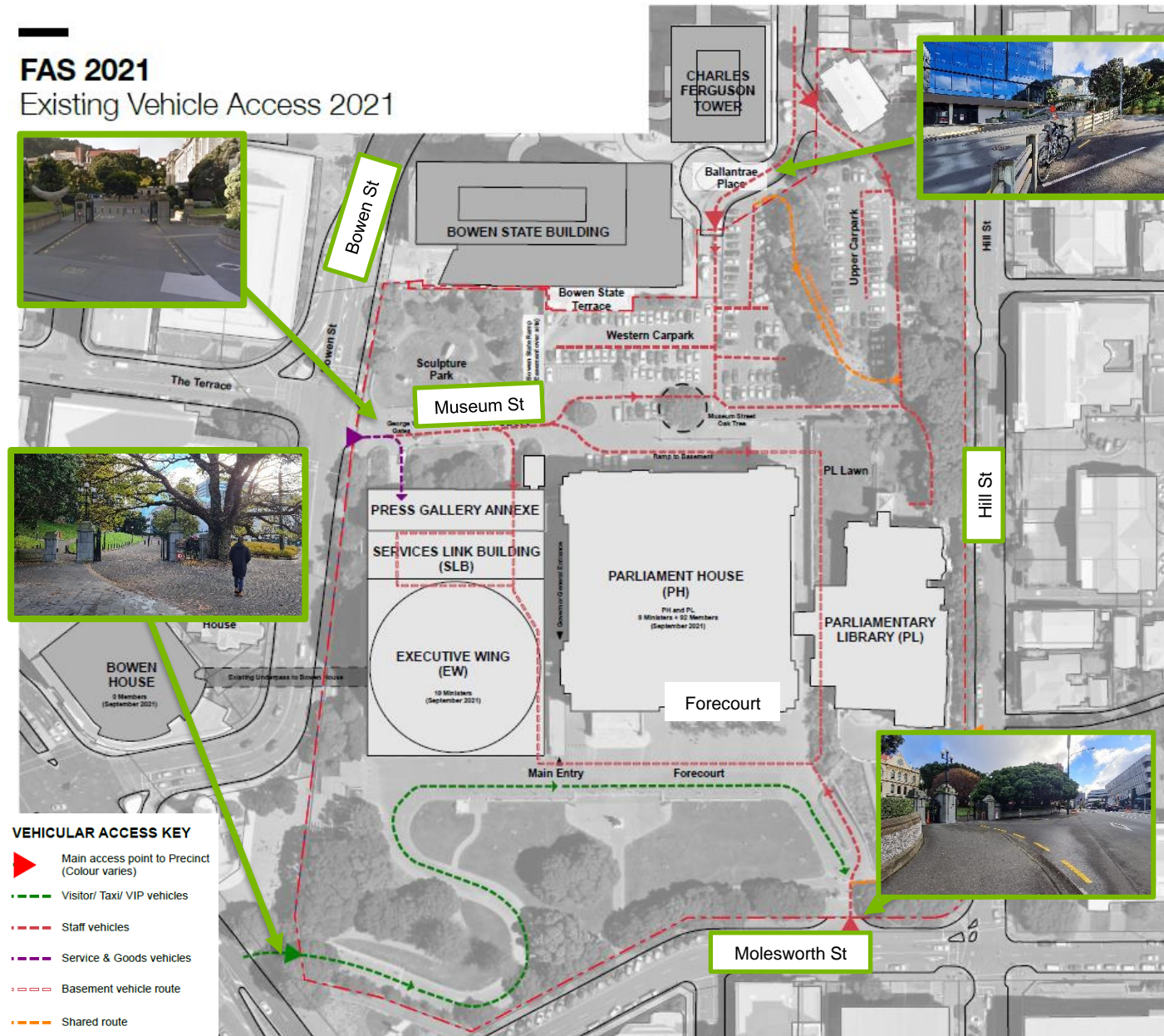

**Figure 31: Existing Vehicle Access and Egress Movements**

Service vehicles primarily access and egress the site via Museum Street. The primary service area is located along Museum Street. Some service vehicles also access the PH/PL basement as shown in Figure 32 below.



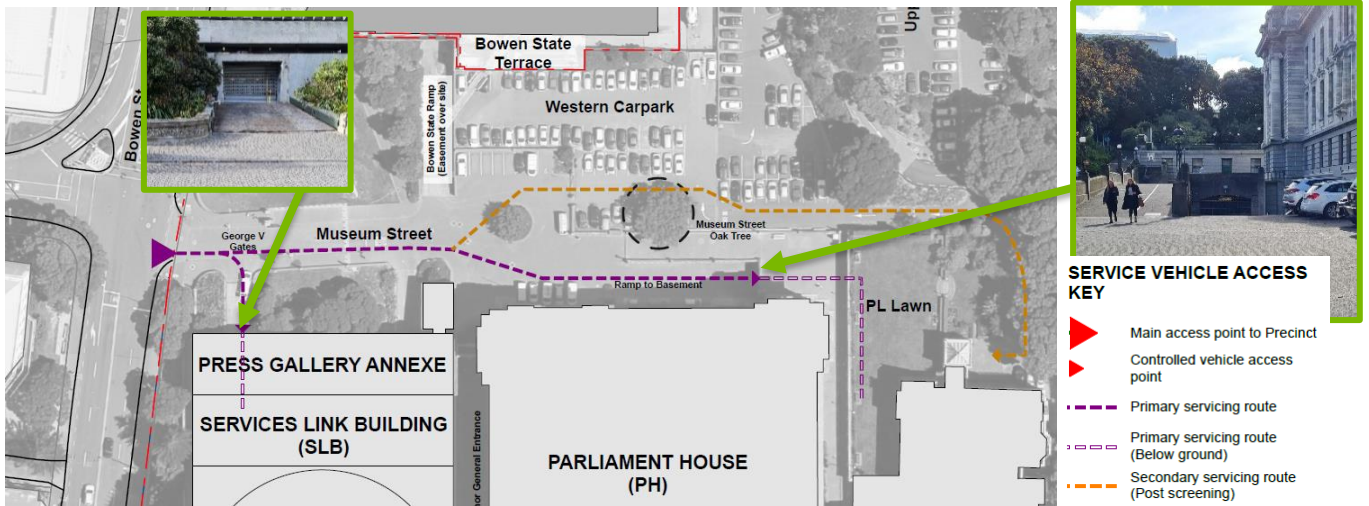

Figure 32: Service Vehicle Movements

### 4.1.2 Existing Pedestrian and Cycle Access

Pedestrians and cyclists' access the site via multiple points of entry located along; Bowen Street, Lambton Quay, Molesworth Street and Hills Road. Cyclists may also access the site via Ballantrae Place. Within the site, pedestrians and cyclists share the carriageway with slow moving vehicles (speed restrictions to 10km/hr).

#### FAS 2021

#### Existing Pedestrian Access 2021

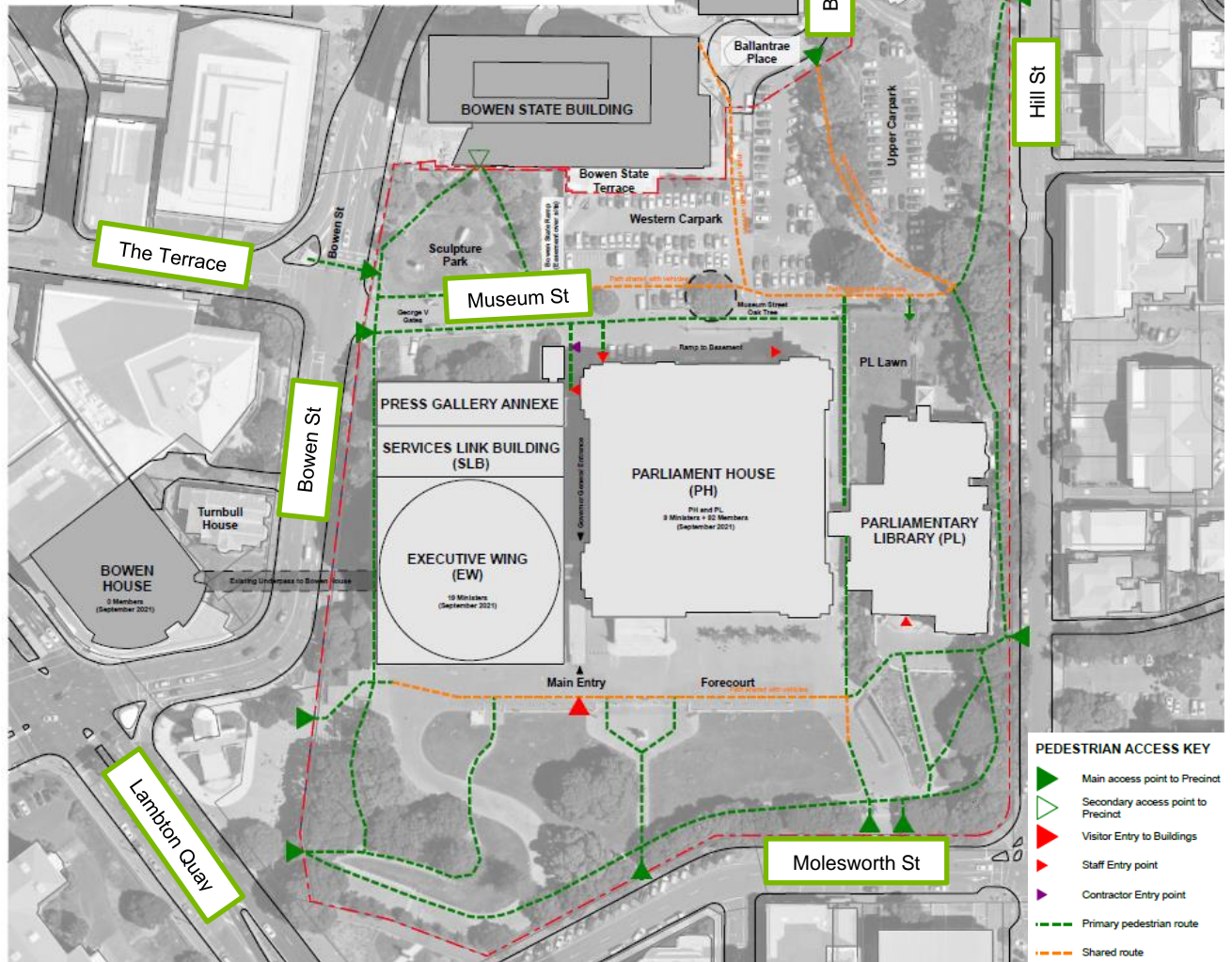



Figure 33: Existing Pedestrian and Cyclist Access Routes

### 4.1.3 Existing Cycle Parking Provision

Approximately 53 cycle parks are currently provided on site. These cycle stands are secure and accessible by staff only. Cycle parking is available in the basement of the Executive Wing and Forecourt area. As shown in Figure 34 and Figure 35 below, existing cycle parks were observed to be well used.



Figure 34: Existing Cycle Parking

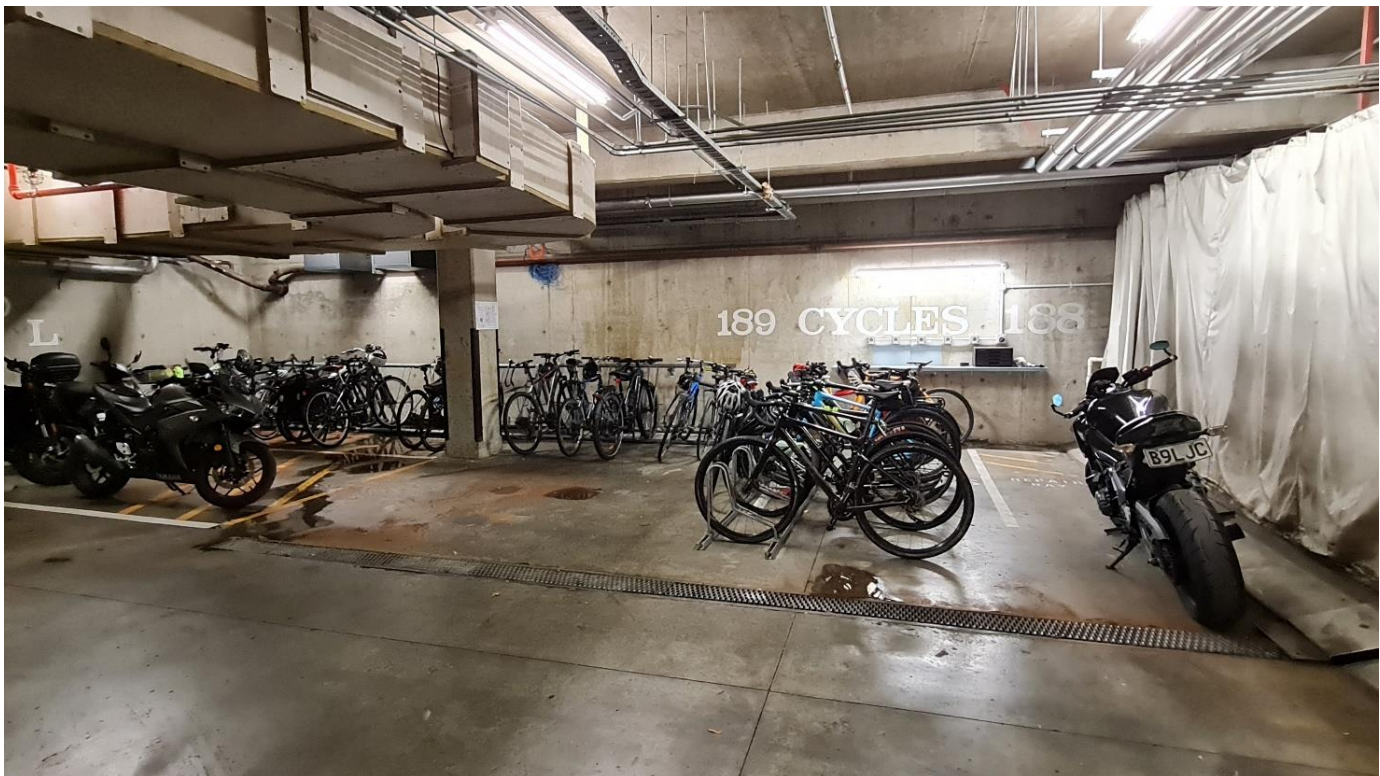

Figure 35: Existing Cycle Parking



## 4.1.4 Existing Vehicle Parking

Existing on-site parking spaces are available for staff use only. Individual staff members are provided access to park on site. Visitor parking spaces are not provided on site. Parking spaces in Bowen House are rented by the Parliamentary Precinct for use by staff.

### FAS 2021

#### Existing Carparking Plan 2021

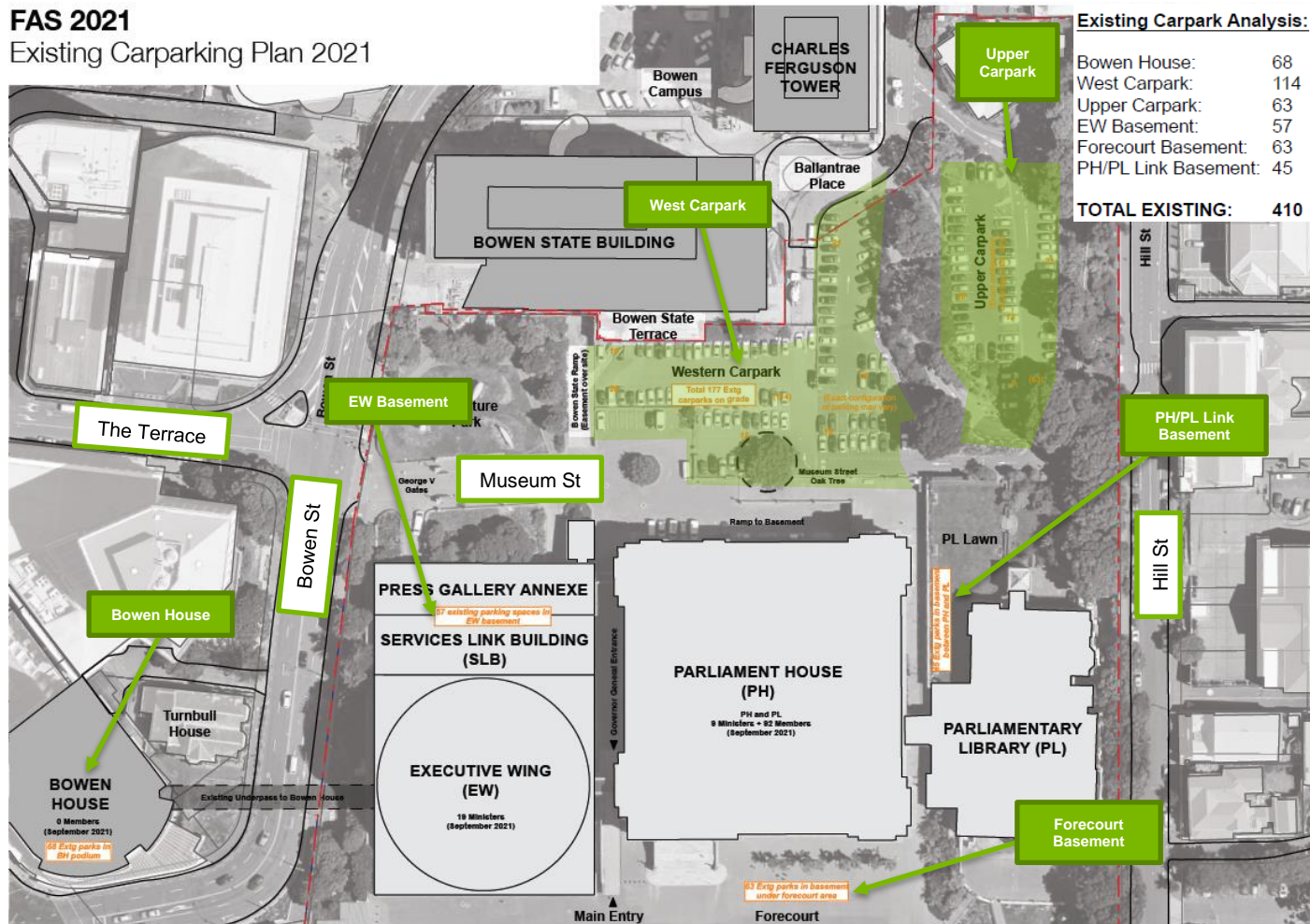

Figure 36: Existing Parking Provision

Approximately 4 mobility parking bays are currently provided on site. Table 3 below provides a summary of existing car parks.

Table 3: Existing Carpark Summary

Car Park	Total
Bowen House	68
West Carpark	114
Upper Carpark	63
EW Basement	57
Forecourt Basement	63
PH/PL Link Basement	45
<b>Total</b>	<b>410</b>

## 5 Proposed Development

This ITA considers the proposal to redevelop the Parliamentary Precinct. Figure 37 demonstrates the proposed masterplan for the Parliamentary Precinct which includes the three new-build locations currently at design stages.

*Note The outlines of each building are indicative only.*

### Future Accommodation Strategy

#### Masterplan Summary - Parliamentary Precinct west

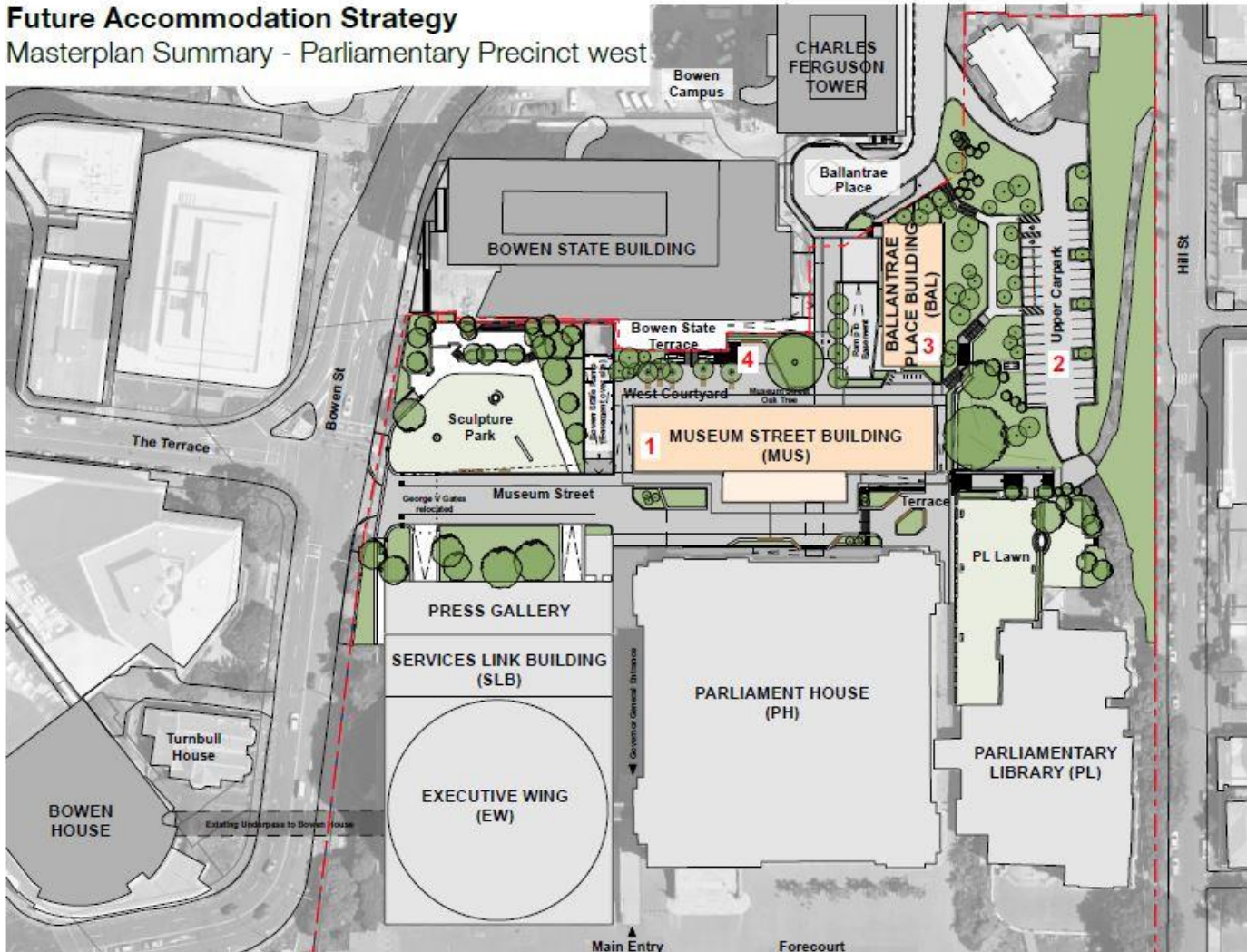

Figure 37: Proposed Site Plan

A summary of the proposed changes is provided below.

#### Future Museum Street (MUS) Building (Refer to 1 in Figure 37 above) details include:

- The proposed Museum Street Building (MUS) will be a six storey (basement and ground floor plus five storeys), building situated within the existing West Carpark. It is designed to accommodate members from multiple political parties, but also to provide general office accommodation.
- The basement level of the MUS Building will accommodate:
  - Vehicle access (ramp access from ground level) but no carparking with the exception of a single mobility bay. Basement vehicular linkages to the basement car parking in the PH/PL basement and the Executive Wing basement will be provided.
  - Miscellaneous plant items and storage
  - Lift lobby
  - Bicycle parking for 81 bicycles. Cyclists can then take the lift or stairs up to the showers on the ground floor

**Parking Reduction (Refer to 2 in Figure 37 above) details include:**

- Current precinct carparking capacity is approximately 410 parks.
- Precinct parking provision will be reduced by approximately 42% due to loss of surface parking and reduced access to Bowen House carparking,
- Approximately 171 parks (inclusive of 8 mobility parks) will be provided.

**Future Ballantrae Place (BAL) Building (Refer to 3 in Figure 37 above) details include:**

- The proposed Ballantrae Place Building (BAL) (basement, ground plus partial first floor screened roof level exterior plant) is located on the area of the Parliamentary Precinct accessed via Ballantrae Place.
- The building is designed:
  - as the single point of entry for incoming goods to the precinct.
  - as a point of entry for ‘non-business’ visitors and pre-screened contractors to the precinct.
  - to accommodate outgoing goods, large items and rubbish and recycling. The dock way is designed to accommodate a medium rigid vehicle with skip pick up and throw-over height.
  - to house precinct wide plant.
- The basement level of the building will accommodate:
  - Building Core
  - Indoor services plants area
  - Circulation zone to basement (small vehicular)
- The ground level of the building will accommodate:
  - Security screening for goods and people, sorting and storage area
  - Rubbish/recycling sorting room
  - Skip Storage Area
  - Loading Dock (large enough for 8m MRV with overhead skip loading)
  - Visitor lobby and waiting space
  - Building Core
  - Goods lift to all areas with golf-cart parking or similar in the basement
- Level 1 of the building will accommodate:
  - Double height void space over truck dock
  - Internal plant
  - Meeting and break out space

## 5.1 Site Access

No changes to the design or construction of the existing vehicle accesses to/from the site from Museum Street, Lambton Quay, Molesworth Street or Ballantrae Place are proposed. Instead, the way existing vehicle accesses to the site are used will be altered. Existing and proposed vehicle access to the site is shown in Figure 38 and Figure 39 respectively.

The following changes are proposed in terms of vehicular access to the site:

- Regular service vehicles will be restricted from accessing the site via Museum Street. Service vehicles will instead access and egress the site via Ballantrae Place. Vehicle tracking demonstrating the forward-facing entry and egress movements of a Large Rigid Vehicle and Medium Rigid Vehicle to the BAL building internal loading dock and external layby area are provided in Appendix C.



- Parliamentary staff and visitor vehicular access to the site via Museum Street will be restricted. Access to the site via Museum Street will be restricted to private vehicles accessing the Bowen State parking area, the Governor-General, authorised building / site maintenance vehicles and some infrequent VIP visitors to the Parliamentary Precinct. Museum Street may also be used for site access during special events held within the Parliamentary Precinct. A turning space accommodating turning movements of a 99-percentile vehicle will be provided at the end of Museum Street, to restrict vehicle movements further into the site. Vehicle tracking demonstrating the turning movement of a 99-percentile vehicle is provided in Appendix C.
- Day to day parliamentary staff will primarily access the site via Ballantrae Place.
- Visitors and taxis will continue to access the site via Lambton Quay (egressing via Molesworth Street) and Ballantrae Place. The feasibility of a future taxi stand area along Bowen Street (near the existing Sculpture Garden) to service visitors to the Parliamentary Precinct is currently being reviewed by Parliamentary Service. The provision of this taxi stand area is yet to be determined and has therefore not been assessed as part of this report.

## FAS 2021

### Existing Vehicle Access 2021

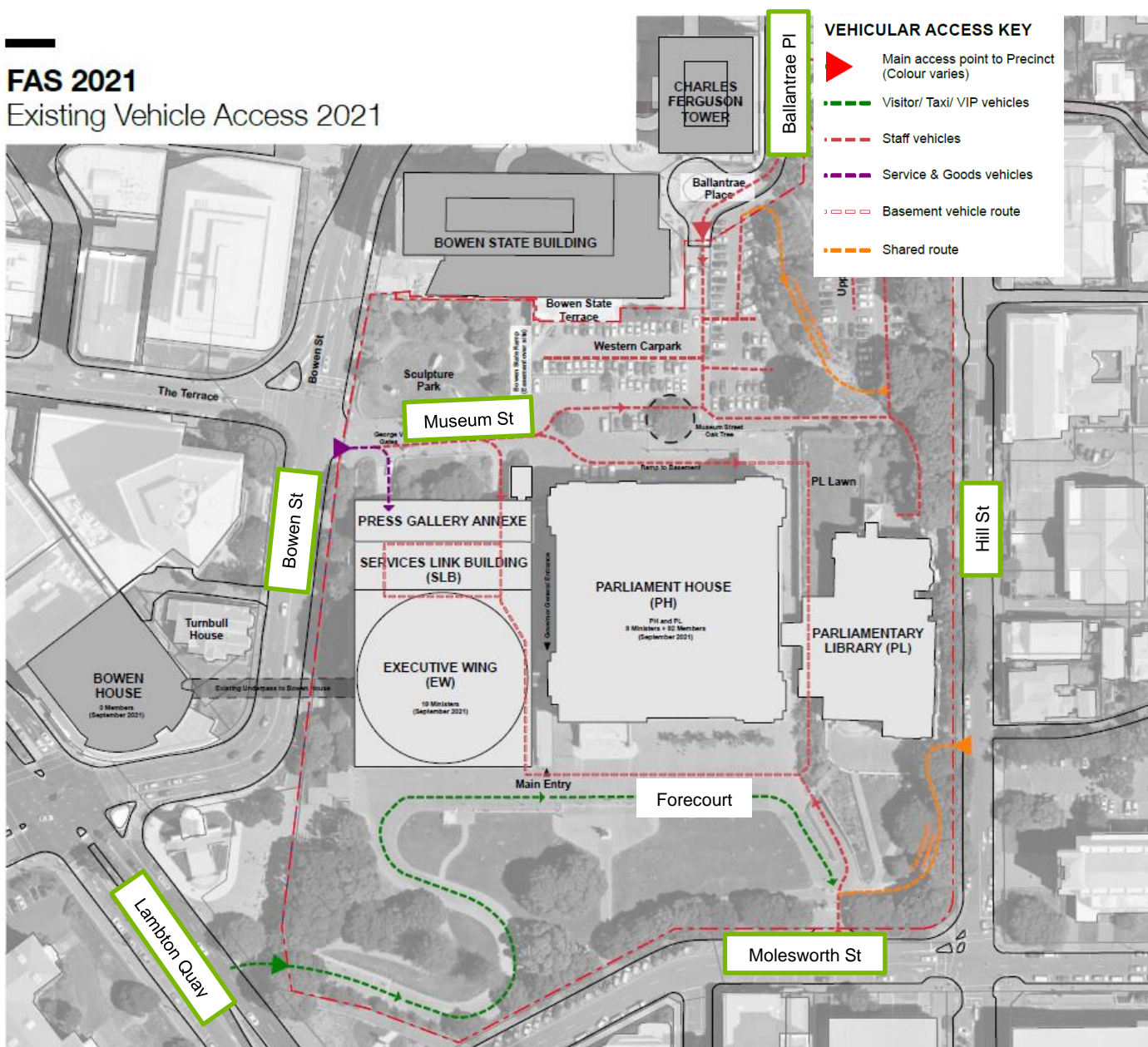

Figure 38: Existing Vehicle Access and Internal Movements

## Future Accommodation Strategy Future Vehicle Access

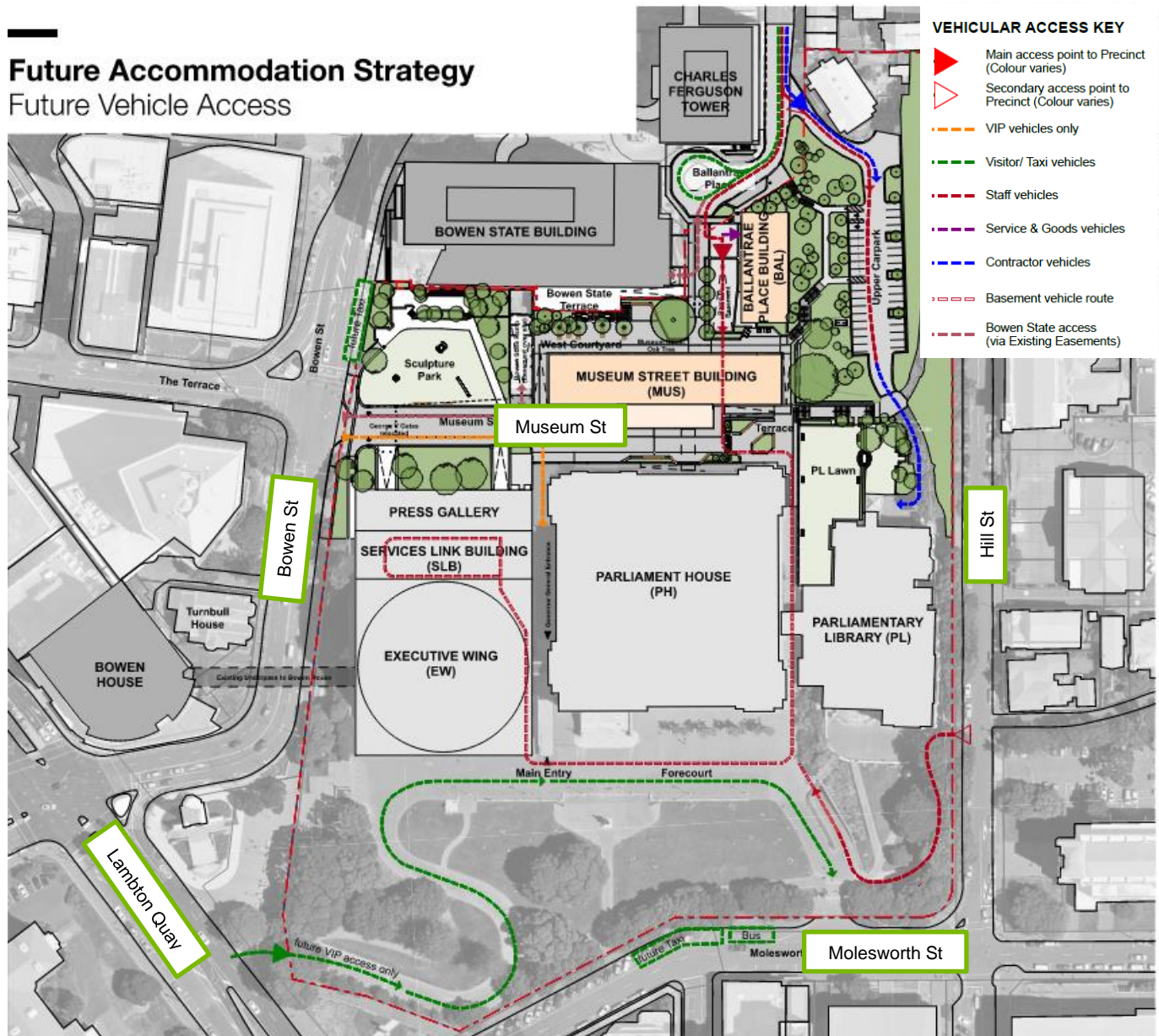

Figure 39: Proposed Vehicle Access and Internal Movements

Removing day to day service, staff and visitor vehicle entry and egress movements from the Museum Street site access is expected to significantly improve the functionality and safety of vehicles, pedestrians and cyclists operating in vicinity of the Bowen Street/Museum Street/The Terrace intersection.

## 5.2 Parking Provision

A total of 171 parking spaces will be provided on-site representing a total parking reduction of 42%.

- No new parking spaces are proposed on site, with the exception of 1 new mobility parking bay in the MUS basement.
- Some existing staff parking spaces in the EW wing basement will be converted; 5 to new mobility parks (for a total of 7 mobility parks in the EW basement) and 2 to VIP drop off bays.
- A total of 8 mobility parking spaces will be provided on site.
- All other retained onsite parking spaces will remain unchanged. Parking provided in the Forecourt Basement and PH/PL Link Basement will be retained as existing.



- Parking spaces rented from the Bowen House building will be reduced from 68 to 0.
- At this stage, it is envisaged that the area adjacent to the proposed BAL building can be allocated for courier (P5) or taxi use.
- Parking within the West Carpark will be reduced from 114 to 0 to accommodate the proposed MUS Building.
- Parking spaces in the upper carpark will be reduced from 63 to 34.
- Contractors servicing the site will park in the Upper Carpark when required.
- No visitor parks are proposed on-site as per the existing situation.
- Only specific staff will be allowed to use on-site staff parking spaces. Staff not provided with parking access will not be able to park on site.

### Future Accommodation Strategy Future Carparking Plan

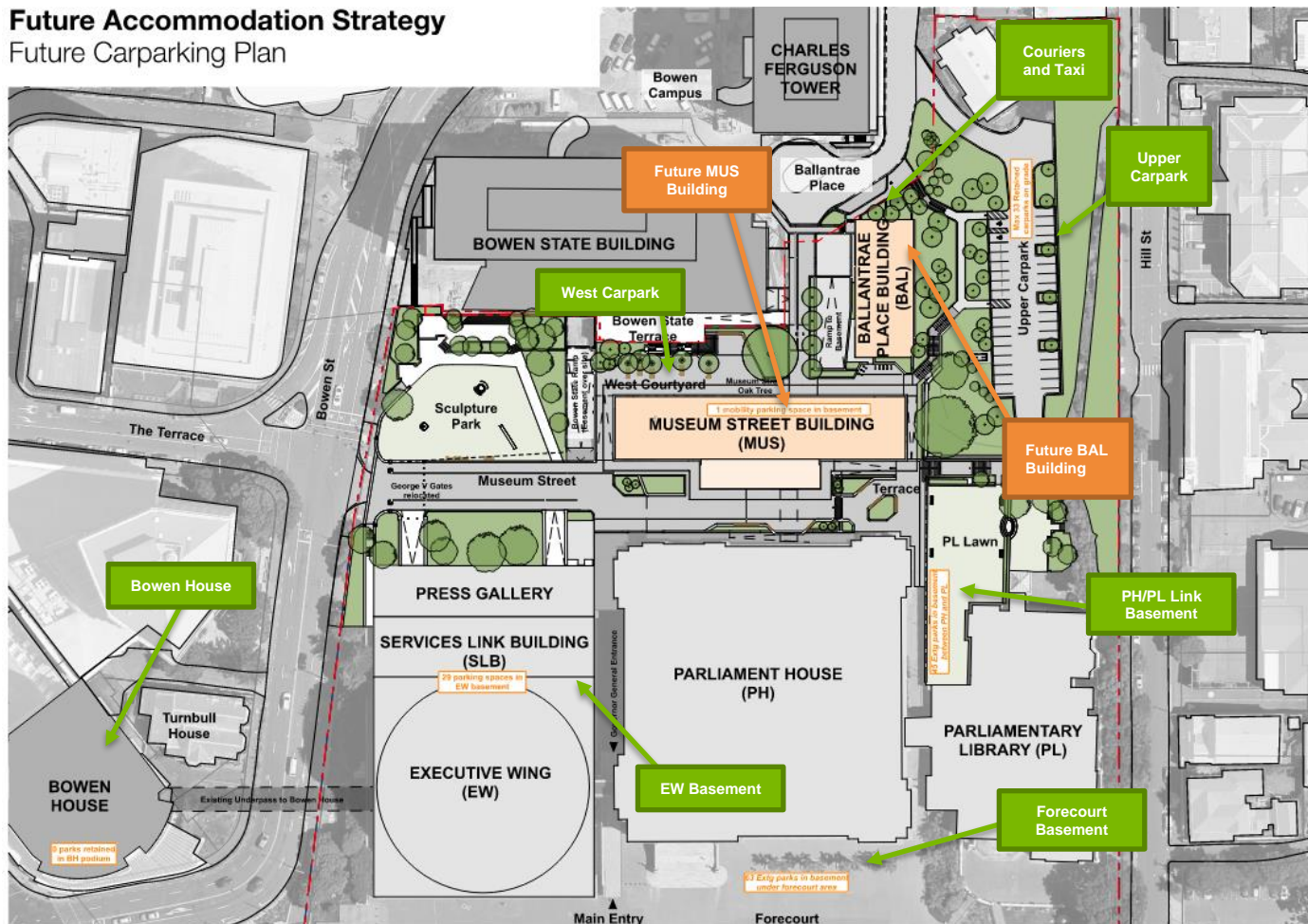

Figure 40: Future Parking Provision

A summary of the proposed on-site parking provision is provided in Table 4 below.

Table 4: Proposed Parking Provision

Car Park	Staff	Staff EV	VIP Drop Off	Mobility	Proposed Total	Existing Total
Bowen House					0	68
West Carpark					0	114
Upper Carpark	34				34	63
EW Basement	40	8	2	7	57	57
Forecourt Basement	63				63	63
PH/PL Link Basement	45				45	45



Forecourt Basement	63				63	63
PH/PL Link Basement	45				45	45
Museum Street Building (MUS)				1	1	0
<b>Total</b>	<b>153</b>	<b>8</b>	<b>2</b>	<b>8</b>	<b>171</b>	<b>410</b>

Reducing the onsite parking provision is expected to significantly reduce staff reliance on private vehicle use. Due to the accessibility of the site via public transport and cycle paths, staff and visitors are expected to shift to more sustainable modes of travel.

### 5.3 Servicing

The site is currently, and will continue to be, serviced by a variety of vehicles (cars, courier vans, medium sized trucks). Servicing of the site will occur on the ground floor of the proposed BAL Building. Access to and from the site for day to day service vehicles will occur via Ballantrae Place.

The proposed internal loading dock has been designed to accommodate an 8m Medium Rigid Vehicle (MRV) with overhead skip loading. The external loading bay has been designed to accommodate entry and egress movements of an MRV. Deliveries to and from the site are not expected to increase due to the proposed works.

Vehicle tracking demonstrating the forward entry and egress movements of a Large Rigid Vehicle to and from Ballantrae Place, and a MRV entering and egressing the loading dock and loading bay are provided in Appendix C.

To ensure the safety of pedestrians and cyclists' operating near the BAL Building, all service vehicles will reverse into the internal loading dock, to egress the BAL building forward facing. The only exception will be the removal of rubbish from the site, as overhead skip loaders load from the front as shown in Figure 41 below. When rubbish pick up occurs on site, security and/or staff will monitor the reversing movement of the vehicle out of the loading dock. Furthermore, warning flash beacon lights will be installed to provide additional warning to pedestrians/cyclists when the loading dock door is opened.

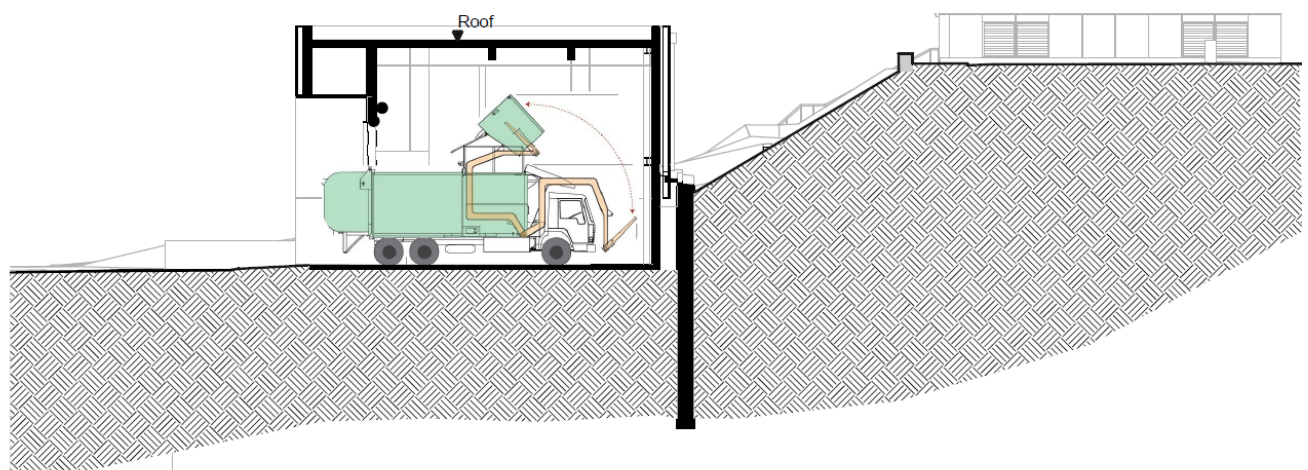

**Figure 41: Overhead skip loader**

Vehicle tracking demonstrating the movements of a large rigid FENZ appliance is provided in Appendix C. As demonstrated, the turning circle of a FENZ type 4,5,6 appliance (RTS 18 large rigid vehicle - refer to Sheet 3) can be accommodated within the legal road boundary and future redevelopment of this area will be undertaken to allow for this turning movement.

## 5.4 Cycle Parking

Additional staff cycle parking will be provided on site as part of the proposed works.

- A new bicycle storage area provided in the basement level of the MUS Building will accommodate 81 bicycles.
- 8 new visitor cycle stands will be provided in the Parliamentary Precinct.

All other existing cycle parks (53 existing stands) will be retained as is. This results in a total of 134 staff cycle stands and 8 visitor cycle stands provided on site.

## 5.5 Internal Vehicle Movements

- Access to the Executive Wing basement carpark and PH/PL basement carpark will occur via the proposed MUS Building underground basement linkage which has been designed (clearance height, width and gradients) to accommodate 99-percentile vehicle movements. The existing vehicle access ramp to the Executive Wing basement from Museum Street will be removed.
- A turning head able to accommodate a 99-percentile vehicle will be provided along Museum Street, reducing vehicle movements near Parliamentary House.
- Due to the removal of surface parking in the West Carpark, and the provision of a turning head on Museum Street, vehicle movements within the site will be simplified, and will primarily occur via existing and proposed basement linkages.

## 5.6 Walking and Cycling Access Arrangements

No changes are proposed to the existing pedestrian/cycle accesses to the project site. The reduction in surface parking provision and the simplification of surface vehicle movements is expected to significantly increase pedestrian and cycle safety by reducing the interaction between cyclist/pedestrians and vehicles. Reducing vehicle access to the site via Museum Street is also expected to increase the safety of pedestrians/cyclists operating at or near the Museum Street / Bowen Street / The Terrace intersection.

## 6 Proposed Trip Generation and Network Effects

Trip generation is typically estimated from trip generation data (e.g. Research Report 453), based on associated Ground Floor Area (GFA) and activity type. Trip generation rates for the site has been calculated but due to data limitations (Refer to Appendix E), it is not considered highly accurate nor applicable to this site or activity.

To understand the expected trip generation of the proposed works, the following has been considered:

- The project proposes a significant decrease in the provision of on-site all-day staff parking. Use of on-site parking spaces will be allocated to specific staff members. This is expected to result in a notable shift (42% of existing staff) towards sustainable modes of travel. This shift will be supported by the accessibility of the site via public transport and cycling.
- The GFA of the project site will increase as part of the proposed works, but an equivalent increase in staff numbers is not anticipated. Instead, some existing parliamentary staff (currently operating within the Parliamentary Precinct or in offices surrounding the Precinct) will be relocated to the new proposed buildings. This is not expected to increase commuter trips to the site due to the capped number of on-site parking spaces and the restricted use of parking within the Precinct.

Commuter vehicle trips to and from the site are therefore expected to decrease due to the proposed works. Furthermore, the reduction in on-site parking provision aligns strongly with the Wellington District Plan objectives of the Central Area which aims to reduce reliance's on private vehicle use.

### 6.1 Network Effects

The following network effects are anticipated due to the proposed works:

- The morning peak hour (7:30 to 8:30am) right turn movements from Bowen Street into Ballantrae Place is the most critical movement in terms of potential network impacts. Site observations indicate that currently, there is little congestion along Bowen Street, with ease of through movements, and minimal delays in undertaking left and right turn movements into Ballantrae Place (less than 30 seconds).
- The proposed works will shift the majority of service, visitor and staff vehicle movements from the Museum Street site access to the Ballantrae Place site access.
- Currently only all-day staff parking is being provided on site. Site observations indicate that the majority of staff enter and leave the site during standard peak periods (7:30am to 8:30am). The provision of parking on-site is proposed to be reduced by approximately 42%.
- Due to the 42% reduction of all-day staff parking on site, a corresponding 42% reduction in staff vehicle entry and egress movements into/from the site in the peak periods is assumed to occur (i.e. in AM peak, right turn entry movements to the site will decrease from 8 to 5)
- Due to the access restrictions proposed at Museum Street, we have assumed that these service, staff and visitor entry and egress movements will shift to the Ballantrae Place/Bowen Street intersection.<sup>1</sup>
- The anticipated impact of the proposed works on the morning peak right turn entry movement into Ballantrae Place from Bowen Street is demonstrated in Table 5.

---

<sup>1</sup> Entry and egress movements into/from Museum Street (left & right turn movements) are assumed to shift accordingly to the Ballantrae Place/Bowen Street intersection.

**Table 5: AM (7:30 to 8:30am) Peak Right Turn Entry Movement into Ballantrae Place**

		Right turn into Ballantrae Place	Max Queue length Observed (vehicles)	Left turn into Ballantrae Place
<b>Existing</b>		49	4 <sup>2</sup>	146
Change	Service Vehicles	1 (entry movements currently occurring at Museum St)		3 (entry movements currently occurring at Museum St)
	Staff Vehicles	5 (58% x 8 entry movements currently occurring at Museum St)		5 (58% x 9 entry movements currently occurring at Museum St)
<b>Total Increase</b>		<b>6 (5 staff + 1 service vehicles)</b>		<b>8 (5 staff + 3 service vehicles)</b>
Expected Total		<b>55 (49 +6) (12% increase)</b>		<b>154 (146+8) (5% increase)</b>

- The proposed works are anticipated to increase right turn movements into Ballantrae Place from Bowen Street by 12% in the morning peak hour.
- To assess the impact of increased right turn movements into Ballantrae Place (from Bowen Street) in the AM Peak Period:
  - An increase of 6 vehicles over the peak hour (7:30 – 8:30am) is equivalent to approximately one additional right turn movement every 10 minutes.
  - On site observations indicated a maximum queue length of 4 vehicles for right turn movements into Ballantrae Place.
  - An additional right turning vehicle every 10 minutes may (worst case assumption) increase the maximum queue length to 5 vehicles.
- The turning bay, including the transition length is approximately 40m long. Assuming a length of 6.5m to accommodate a vehicle and a gap between waiting vehicles, this results in the turning bay and transition length being able to accommodate approximately 6 vehicles waiting to turn right before right turning vehicles encroach on the Bowen Street westbound through lane<sup>3</sup>.
- If the queue length to turn right onto Ballantrae Place increases to 5 vehicles due to the proposed works, the existing turning bay and transition length is expected to accommodate this without impacting significantly on vehicle movements occurring along the adjacent through lane. Changes to the intersection or linemarkings at Ballantrae Place / Bowen Street are therefore not considered necessary to accommodate the proposed works.
- Parliamentary Service have indicated that they will advise regular services occurring via Medium or Large Rigid Vehicles to access the site via left turn movements only at the Bowen Street/Ballantrae Place intersection.
- Reducing right turn entry movements into Museum Street from Bowen Street is anticipated to reduce queueing along the westbound Bowen Street through lane (a right turning queue length of 10 vehicles

<sup>2</sup> Occurred between 8:15am and 8:30am

<sup>3</sup> Waka Kotahi states: ***“It’s alright to drive on a flush median for a short distance if you’re turning into or out of a side road or driveway. You can use them to slow down before making a right-hand turn, or to merge left into a gap in the traffic flow. If you’re using the flush median to make a right-hand turn you should indicate, then steer gently onto the median rather than at an abrupt angle. Use the median as an area to slow down and brake. This way the following traffic doesn’t have to slow down rapidly to avoid you”*** [emphasis added].

was observed between 8:30 and 8:45am during undertaken traffic counts). It can be inferred that queues to turn right increase delays and congestion for westbound through movements along Bowen Street.

### 6.1.1 Ballantrae Place ADT

- Ballantrae Place is classified as a secondary collector road in the ONRC. Secondary roads are considered to be roads which provide links between local areas of population and economic sites<sup>4</sup>. They may be the only route available to some places within a local area.
- Ballantrae Place is a cul de sac road which primarily provides vehicle access to a few activities (the Parliamentary Precinct, the Ministry for Primary Industries, Defence House, a childcare service 'Playhouse Inc' and a Wilson Parking area).
- The ONRC specifies an appropriate ADT of 1000 – 3000 for secondary collector roads.
- The Mobile Roads<sup>5</sup> website estimates an existing ADT of 1670 along Ballantrae Place. Assuming all entry and egress movements to the Parliamentary Precinct currently occurring via Museum Street are shifted to Ballantrae Place, and allowing for a 42% reduction in vehicle movements, this will result in an approximate ADT of 1872<sup>6</sup> along Ballantrae Place.
- This represents an increase in average daily vehicle movements of approximately 12%.
- As a secondary collector road, Ballantrae Place is considered to be able and appropriate to accommodate this increase in daily vehicle movements.

---

<sup>4</sup> <https://www.nzta.govt.nz/assets/Road-Efficiency-Group/docs/onrc-right-road-right-value-right-time-combined-poster.pdf>

<sup>5</sup> <https://www.mobileroad.org/desktop.html>

<sup>6</sup> 349 entry and egress movements were recorded into and out of Museum Street throughout the day. Applying a reduction factor of 42% results in an increase of 202 average daily vehicle movements along Ballantrae Place.



# 7 District Plan Assessment

An assessment of the proposed development against the applicable/relevant rules in Section 13.6.1.3 of the Wellington District Pan has been undertaken and the results of this are summarised in Table 6 below. The rules are summarised in the first column, an assessment of the proposal is described in the second and the resulting status is listed in the third column. Any new potential non-compliances identified are assessed in the following section.

**Table 6: District Plan Assessment**

Rule	Assessment	Status
<b>Vehicle Parking</b>		
<p>13.6.1.3.1 Activities in the Central Area are not required to provide on-site vehicle parking, but where parking is provided, it must not exceed a maximum of:</p> <ul style="list-style-type: none"> <li>■ one space per 100m<sup>2</sup> gross floor area</li> </ul>	<p>The onsite GFA is proposed as detailed below:</p> <ul style="list-style-type: none"> <li>■ Executive Wing: approximately 25,300m<sup>2</sup></li> <li>■ Parliament House: approximately 22,650m<sup>2</sup></li> <li>■ Parliamentary Library: approximately 7,750m<sup>2</sup></li> <li>■ Future Museum Street Building: approximately 9,150m<sup>2</sup></li> <li>■ Future Ballantrae Place Building: approximately 1,000m<sup>2</sup></li> </ul> <p>Precinct total GFA ~ approximately 65,850m<sup>2</sup></p> <p><i>The total maximum permitted number of parking spaces on site is therefore 692.</i></p> <p><i>A total of 171 parking spaces (inclusive of 8 mobility parks) are proposed on site. This represents a reduction in parking provision of 42% from the current parking provision of 410.</i></p>	Compliant

<p>13.3.1 Any activity involving the provision of more than 70 vehicle parking spaces per site, (except for sites within the Operational Port Area or Port Redevelopment Precinct where such parking is a Permitted Activity), is a Discretionary Activity (Restricted) in respect of:</p> <ul style="list-style-type: none"> <li>■ 13.3.1.1 the movement of vehicular traffic to and from the site.</li> <li>■ 13.3.1.2 the movement of vehicular traffic within the surrounding street network.</li> </ul>	<p><i>The proposal provides greater than 70 on-site car parks.</i></p> <p><i>However, the proposal will provide a total of 171 parking spaces which represents a reduction in parking provision of 42%, from the existing 410 parking spaces.</i></p> <p><i>Anticipated effects of the proposed parking changes are provided in Section 6 of this report.</i></p>	<p>Noted.</p>
<p>13.6.1.3.2 All parking shall be provided and maintained in accordance with sections 1, 2 and 5 of the AS/NZS 2890.1 2004, Parking Facilities, Part 1: Off-Street Car Parking.</p>	<p><b>Section 1.4 Classification of Off-Street Parking Facilities</b></p> <ul style="list-style-type: none"> <li>■ Section 1.4 stipulates that off-street parking facilities shall be classified according to the user classes listed in the first column of Table 1.1 (refer to Figure 42 in Appendix B). Dimensional requirements for parking spaces in each user class are specified in Clause 2.4.1. User Class 1A parking shall be restricted to Residential, Domestic and Employee Parking.</li> </ul> <p><i>The retained onsite parking provision will primarily accommodate staff parking and is therefore considered to be User Class 1A.</i></p>	<p>Noted.</p>



### Section 2.3.1 Design Coordination

The layout design of an off-street car park shall consider the entire facility, including parking modules, circulation roadways, access driveways and, if necessary, frontage road access, as an integrated and co-ordinated design. Provision for traffic within a parking facility shall take into account the following:

- The need for traffic to move to and from the frontage road with minimum disruption to through traffic and maximum pedestrian safety.
- Provision of adequate capacity in circulation roadways and parking aisles to handle peak period movements.
- Arrangement of internal roadways to avoid, as far as practicable, conflicts between intersection streams of circulating traffic.
- Provision of minimum length travel paths between entry/exit points and parking spaces.
- Safe treatment of points of conflict with pedestrians and other road users.
- Provision of parking spaces and accessible pedestrian paths for people with disabilities (See AS/NZS 2890.6\*)

*All retained parking spaces on site will remain as existing with the exception of 8 new mobility parking spaces located within the MUS building basement.*

*The functionality and safety of vehicle movements to/from the site are improved through the removal of service vehicle movements at the intersection of Museum Street/Bowen Street/The Terrace.*

*Circulation and internal vehicle movements on site will be simplified through the reduction of surface level vehicle movements through the provision of:*

- *A turning head along Museum Street restricting vehicle movements in vicinity of Parliament House.*
- *Restricting service vehicles movements in vicinity of the BAL Building.*
- *Vehicular access to the Executive Wing basement through a new underground linkage to the MUS Building.*

*These changes will reduce the potential for both vehicle-vehicle and vehicle-pedestrian conflict within the site.*

*A total of 8 mobility bays will be provided on site – these parking spaces have been designed in accordance with the requirements of AS/NZS 2890.6.*

*Minimum length travel paths will be provided to onsite parking and the proposed mobility parking space located within the MUS basement will provided on site in accordance with AS/NZS 2890.6 requirements.*

AS/NZS 2890.6 Section 2.2 Parking Space Dimensions states that an angle parking space shall comprise a combination of areas, as follows:

Compliant

- A dedicated (non-shared space) as follows: In New Zealand – 2400mm wide by 5000mm long.
- A shared area on one side of the dedicated space as follows: In New Zealand – 1100mm wide by 5000mm long. This area may be entirely on the left of entirely on the right side of the dedicated space.

*The proposed mobility bays will be 3.5m wide and 5.0m long and is therefore compliant with the above dimensional requirements.*

AS/NZS 2890.6 Section 2.4 Headroom states that:

- the path of vehicular travel from the car park entrance to all parking spaces for people with disabilities and from those spaces to the car park exit shall have a minimum headroom of 2300mm. The headroom above each dedicated space and adjacent shared area, measured from the level of the dedicated space shall be a minimum of 2500mm.

*The path of vehicular travel to and from the proposed mobility bays will have a clearance height of 2300mm. The headroom above the proposed mobility bay will be 2500mm.*

AS/NZS 2890.6 Appendix B states that:

- For 1-20 parking spaces, not less than 1 mobility space should be provided
- For 21-50 parking spaces, not less than 2 mobility spaces should be provided
- For every additional 50 car spaces, not less than 1 mobility space should be provided

*A total of 171 carparks will be provided on site. This results in a requirement for 4 mobility bays. A total of 8 mobility parks will be provided on site.*



	<p><b>Section 2.3.2 Parking Angle</b></p> <p>Parking angles used in off-street car park shall be as follows:</p> <ul style="list-style-type: none"> <li>■ 90-degree angle parking: Parking aisles for 90-degree parking shall be designed for two-way movement even though one-way movement may need to be imposed in some instances.</li> <li>■ 30-, 45- or 60-degree angle parking: Where space is limited or does not lend itself to 90-degree parking, 30-, 45- or 60-degree parking may be used instead. Aisles serving such spaces shall be one-way (except where parallel parking is allowed on one side, see Clause 2.4.4) with forward entry into spaces only.</li> <li>■ Parallel parking: Parallel parking shall be provided as set out in Clause 2.4.4</li> </ul> <p><i>All retained parking spaces on site will remain as existing. The proposed 90-degree mobility parking spaces are located within the MUS basement.</i></p>	Compliant.
	<p><b>Section 2.3.3 Parking Aisle Length</b></p> <ul style="list-style-type: none"> <li>■ If parking aisle exceeds 100m in length, (i.e. more than 40 x 90-degree parking spaces on either side) traffic control devices such as speed humps (see Clause 4.9) shall be placed along the parking aisle to control vehicle speeds. Where vehicle negotiable of such devices may lead to structural damage, compliance with this requirement may be waived.</li> </ul> <p><i>All parking aisles will be retained as existing. No existing parking aisles exceeds 100m in length.</i></p>	Compliant.
	<p><b>Section 2.4.1 Angle Parking Spaces</b></p> <ul style="list-style-type: none"> <li>■ Section 2.4 states that dimensions of all angle parking shall be provided in accordance with AS/NZS 2890.1 2004 Figure 2.2, subject to the following exception: <ul style="list-style-type: none"> <li>■ In New Zealand: The space may be marked to a shorter length (nominally 5.0 m) as specified in Clause 4.4.1. There shall be no consequential reduction in the combined length of space and width of parking aisle from that given in Figure 2.2.</li> </ul> </li> </ul> <p><i>All proposed parking spaces are compliant with this requirement.</i></p>	Compliant.
		Compliant

	<p><b>Section 2.5.2 Layout Design of Circulation Roadways and Ramps</b></p> <p>Cross sections of circulation roadways and ramps shall be as illustrated in Figure 2.8 (refer to Figure 43). Design requirements and dimensions shall be as follows for straight roadways and ramps:</p> <ul style="list-style-type: none"> <li>■ One-way roadways or ramps – 3.0m minimum between kerbs</li> <li>■ Two-way roadways or ramps – 5.0m minimum between kerbs</li> <li>■ Double roadways or ramps – where there are to be two parallel roadways or ramps, separated by a raised median or separator, each roadways or ramp shall be designed as a one-way roadway or ramp, and the median or separator shall be 600mm minimum in width and between 125mm and 150mm in height, the preferred height being 125mm.</li> </ul> <p><i>The access ramp into the Museum Street basement is greater than 5m in width.</i></p>	Compliant.
	<p><b>Section 2.5.3 Circulation Roadway and Ramp Grades</b></p> <p>For straight ramps for private or residential car parks (other than domestic driveways, see clause 2.6) as follows:</p> <ul style="list-style-type: none"> <li>■ Longer than 20m – 1 in 5 (20%) maximum</li> <li>■ Up to 20m long – 1 in 4 (25%) maximum. The allowable 20m maximum length shall include any parts of grade change transitions at each end that exceed 1 in 5 (20%)</li> <li>■ A stepped ramp comprising a series of lengths each exceeding 1 in 5 (20%) grade shall have each two lengths separated by a grade of not more than 1 in 8 (12.5%) and at least 10m long.</li> <li>■ Grade transitions – transitions of 2.0m in length will usually be sufficient to correct bottoming or scraping at grade changes up to 18%. They may be in the form of a simple chord with grade calculated as half the algebraic sum of the two adjacent grades, as illustrated, but for vehicle occupant comfort may be constructed as short vertical curves.</li> </ul> <p><i>The access ramp into the MUS building basement has a length less than 20m and a maximum grade of 1:6 with transitions of: 3m length at 1:10 and 2.8m length at 1:8.</i></p>	Compliant.



	<p><b>Section 5.2 Column Location and Spacing</b></p> <p>The dimensions for locating columns in short span structure shall be as given in Figure 5.1 of AS/NZS 2890.1:2004. The design envelope around a parked vehicle which is to be kept clear of columns, walls or other obstructions, is shown in Figure 5.2 (refer to Figure 44 in Appendix B). If this requirement is met, the dimensions in Figure 5.1 will also be achieved.</p> <p><i>All retained onsite parking will remain as existing. The proposed mobility bays within the MUS basements will be compliant with the above spacing requirements.</i></p>	Compliant.
	<p><b>Section 5.3.1 Headroom General Requirements</b></p> <p>To permit access for both car and light vans, the height between the floor and an overhead obstruction shall be a minimum of 2200mm. AS/NZS 2890.6* requires than any vehicle path of travel to or from a parking space for people with disabilities has a clearance of 2300mm.</p> <p><i>All parking spaces and vehicle access routes have a minimum headroom of 2200mm, and the vehicle path to mobility parking spaces have a clearance headroom of 2300m.</i></p>	Compliant.
<ul style="list-style-type: none"> <li>■ 13.6.1.3.3 Open vehicle parking areas must not be situated at ground level at the front of sites to which standard 13.6.3.7.1 (display windows) applies.</li> </ul>	<p><i>All retained onsite parking will remain as existing. The proposed mobility bays are located within the MUS basement and is therefore compliant with this requirement.</i></p>	Compliant.
<b>Servicing</b>		
<p>13.6.1.3.4 On each site in the Central Area at least one loading area must be provided.</p>	<p><i>A dedicated loading dock and loading bay is provided within and alongside the Ballantrae Place building respectively.</i></p>	Compliant.
<p>13.6.1.3.5 Turning paths shall be based on the standard for a medium rigid truck as illustrated in Figure 45 of Appendix B..</p>	<p><i>Entry and egress movements of a Large Rigid Vehicle and Medium Rigid Vehicle into the proposed internal loading dock within the Ballantrae Place Building is provided in Appendix C.</i></p>	Compliant

13.6.1.3.6 For loading areas located outdoors, the minimum width shall be 3 metres and the minimum length 9 metres.	<i>The proposed external loading bay in the Ballantrae Place has a width of 3.0m and a length of 10.5m.</i>	Compliant.
13.6.1.3.7 For loading areas located within a building, the minimum width shall be 4 metres and the minimum length 9 metres.	<i>The internal loading dock will have a width of 4.5m and a length of 10.5m.</i>	Compliant.
13.6.1.3.8 Where loading areas are located within a building, a minimum height clearance of 4.6 metres is required.	<i>A clearance height of greater than 4.6m will be provided for the internal loading dock within the BAL building.</i>	Compliant
13.6.1.3.9 For buildings serviced by lifts, all levels shall have access to a loading area by way of a lift	<i>All levels of the Ballantrae Place building have access to the loading area via lift</i>	Compliant
13.6.1.3.10 The loading area shall be located no further than 15 metres from a lift and there shall be level access between them.	<i>The loading area is located such that the requirements of this rule are met.</i>	Compliant
<b>Site Access for Vehicles</b>		
13.6.1.3.11 Site access shall be provided and maintained in accordance with Section 3 of the joint Australian and New Zealand Standard 2890.1 – 2004, Parking Facilities, Part I: Off-Street Car Parking.	<p><b>Section 3.2.1 Access Driveway Widths</b></p> <p>Except as specified in Clause 3.2.2, where traffic flow data on an access driveway is either known or can be determined by separate means more accurately than by use of the categories in Table 3.1 of AS/NZS 2890.1 – 2004, such data may be used to determine driveway widths by accepted design procedures. In the absence of such data the widths given in Table 3.2 shall be used.</p> <p>Where separate entry and exit roadways are provided, they shall be at least 1m apart.</p> <p><i>All access driveways to and from the project site will be retained as existing with the total number of parking spaces accessed via vehicle accesses reduced.</i></p>	Compliant.

	<p><b>Section 3.3 Gradients of Access Driveways</b></p> <p>At entry and exit points, the access driveway should be graded to minimize problems associated with crossing the footpath and entering the traffic in the frontage road.</p> <p>Maximum gradients on and near access driveways, other than at domestic properties, shall be as follows:</p> <ul style="list-style-type: none"> <li>■ Property line/building alignment/pedestrian path: maximum 1 in 20 (5%) between edge of frontage road and the property line, building alignment or pedestrians path, and for at least the 6m into the car park (except as provided below): <ul style="list-style-type: none"> <li>■ The user class is Class 1, 1A or 2 only</li> <li>■ The maximum car park size 25 car spaces for entry from an arterial road, or 100 car spaces for entry onto a local road</li> </ul> </li> <li>■ Vehicle control points: maximum 1 in 20 (5%) for at least 6m prior to the control point</li> <li>■ Queuing area: maximum 1 in 10 (10%) for not less than 0.8m of the queue length determined in AS/NZS 2890.1 2004 Table 3.3.</li> <li>■ Across footpaths: where the driveway crosses a footpath, the driveway grade shall be 1 in 40 (2.5%) or less across the footpath over a lateral distance of at least 1.0m.</li> </ul> <p><i>All access driveways to and from the project site will be retained as existing with the total number of parking spaces accessed via vehicle accesses reduced.</i></p>	Compliant.
	<p><b>Section 3.4 Queuing Areas</b></p> <p>At an entry point, the queuing area to be provided between the vehicular control point and the property boundary shall be sufficient to allow a free influx of traffic which will not adversely affect traffic or pedestrians flows in the frontage road. No parking space manoeuvres shall be allowed to take place within the queuing area. In the absence of more specific guidance, the size of the queuing area shall be calculated from Table 3.3, for a car park with boom gates and ticket issuing devices at entry points, and based on the proposed size of the parking station and anticipated peak hourly inflow of traffic.</p> <p><i>All access driveways to and from the project site will be retained as existing with the total number of parking spaces accessed via vehicle accesses reduced.</i></p>	Compliant.



	<p><b>Section 3.2.4 Sight Distance at Access Driveway Exits</b></p> <p>Access driveways need to be located and constructed so that there is adequate entering sight distance to traffic on the frontage road and sight distance to pedestrians on the frontage road footpath for traffic entering the frontage road, as follows:</p> <ul style="list-style-type: none"> <li>■ Entering sight distance: Unsignalised access driveways shall be located so that the intersection sight distance along the frontage road available to drivers leaving the car park or domestic driveway is at least that shown in AS/NZS 2890.1 Figure 3.2.</li> <li>■ Sight distance to pedestrians: clear sight lines as shown in AS/NZS 2890.1 2004 Figure 3.3 shall be provided at the property line to ensure adequate visibility between vehicles leaving the car park or domestic driveway and pedestrians on the frontage road footpath.</li> </ul> <p><i>All access driveways to and from the project site will be retained as existing.</i></p>	Compliant.
<p>13.6.1.3.12 No vehicle access is permitted to a site across any restricted road frontage identified on District Plan Map 34 provided that this shall not prevent the continuation or the undertaking of any Permitted Activity on a site involving the use of any lawfully established vehicle access.</p>	<p><i>All access driveways to and from the project site will be retained as existing.</i></p>	Compliant.
<p>13.6.1.3.13 There shall be a maximum of one vehicle access to any site except that sites with more than one frontage may have one access across each frontage.</p>	<p><i>The site is fronted by five roads (Hill Street, Bowen Street, Molesworth Street, Lambton Quay and Ballantrae Place) and has four existing vehicle access which will be retained as is.</i></p>	Compliant
<p>13.6.1.3.14 Both the entry and exit of vehicles onto the carriageway of the most adjacent street shall be in a forward direction.</p>	<p><i>All vehicle movements into and from the site will occur forward facing.</i></p>	Compliant

<p>13.6.1.3.15 The width of any vehicle crossing to a site shall not exceed 6 metres.</p>	<p><i>No changes proposed to existing site accesses.</i></p>	<p>Compliant</p>
<p>13.6.1.3.16 Where vehicular access can be provided from a service lane, a right-of-way registered in favour of the site or other private road, or private right-of-way, no vehicle access shall be from a street.</p>	<p><i>Not applicable.</i></p>	<p>Not Applicable.</p>
<p>13.6.1.3.17 Subject to standard 13.6.1.3.12 no vehicular access shall be situated closer to an intersection than the following:</p> <ul style="list-style-type: none"> <li>■ Arterial, principal and collector streets: 20m</li> <li>■ Other streets: 15m</li> </ul>	<p><i>Access to the site via Museum Street is located less than 20m to the intersection of Bowen Street/The Terrace.</i></p> <p><i>This is an existing non-compliance. Movements at this intersection will be improved by the removal of service vehicle entry/exit movements into or out of the site via Museum Street.</i></p>	<p>Existing Non-Compliance.</p>
<p>13.6.1.3.18 No access shall be provided to a primary street on a site that also has frontage to a secondary street.</p>	<p><i>Not applicable.</i></p>	

## 8 Recommendations and Conclusions

This report assesses the various transport and access elements of the Parliamentary Future Accommodation Strategy (FAS) project to support the Outline Plan of Works.

The proposal includes a reduction of on-site staff parking by 42%, significantly reduces vehicle access to the Parliamentary Precinct via Museum Street, relocates servicing of the site to the proposed BAL building (accessed via Ballantrae Place) and increases on-site cycle and mobility parking. Internal vehicle movements within the site are simplified and primarily restricted to basement linkages to increase the safety of pedestrians and cyclists within the site.

The surrounding area is able to accommodate the anticipated impacts, which is expected to include a reduction in private vehicle use to/from the site.

The proposed works aligns with the WDP's objectives to reduce parking provision in the Central Area and is expected to induce an uptake in cycling and public transport use. An assessment against the Wellington District Plan has also been conducted to demonstrate alignment with the District Plan requirements, and the site and proposed works are well aligned with all matters.

Overall, the proposal is considered acceptable from a traffic and transport perspective and is expected to increase the safety and functionality of the Parliamentary Precinct.



# Appendix A – CAS Reports

## Untitled query

### Saved sites

FAS - Site 2

### Crash year

2011 — 2020

## Site details report

Fatal crashes: 0 | Injury crashes: 39 | Non-injury crashes: 59 | Total crashes: 98

### Overall crash statistics

#### Crash severity

Crash severity	Number	%	Social cost \$(m)
Fatal	0	0	0
Serious	7	7.14	4.93
Minor-injury	32	32.65	2.94
Non-injury	59	60.20	1.36
TOTAL	98	100	9.23

### Overall casualty statistics

#### Injury severity

Injury severity	Number	% all casualties
Fatal	0	0.00
Serious Injured	7	17.07
Minor Injured	34	82.93
TOTAL	41	100.00

## Crash numbers

Year	Fatal	Serious	Minor	Non-injury
2011	0	0	2	3
2012	0	2	4	4
2013	0	1	6	7
2014	0	0	3	8
2015	0	1	5	9
2016	0	1	1	8
2017	0	1	2	5
2018	0	1	4	1
2019	0	0	4	9
2020	0	0	1	5
TOTAL	0	7	32	59
Percent	0	7.14	32.64	60.18

## Casualty numbers

Year	Fatal	Serious Injured	Minor Injured
2011	0	0	2
2012	0	2	5
2013	0	1	6
2014	0	0	3
2015	0	1	5
2016	0	1	1
2017	0	1	2
2018	0	1	4
2019	0	0	4
2020	0	0	2
TOTAL	0	7	34
Percent	0.00	17.07	82.93

Note: Last 5 years of crashes shown (unless query includes specific date range).

## Crash type and cause statistics



## Crash type

Crash type	Crash numbers	% All crashes
Overtaking crashes	14	14.29
Straight road lost control/head on	4	4.08
Bend - lost control/Head on	4	4.08
Rear end/obstruction	40	40.82
Crossing/turning	20	20.41
Pedestrian crashes	16	16.33
Miscellaneous crashes	0	0
TOTAL	98	100

## Casualty types

Casualty types	Fatalities	Serious injuries	Minor injuries
Cyclists	0	3	11
Drivers	0	0	3
Motorcycle pillions	0	0	0
Motorcycle riders	0	3	6
Passengers	0	0	2
Pedestrians	0	1	12
Other	0	0	0
TOTAL	0	7	34

Note: Motorcycle stats include Mopeds.



## Driver and vehicle statistics

## Crash factors

Crash factors	Crash numbers	% All crashes
#N/A	7	7.14
Alcohol	5	5.10
Disabled, old age or illness	0	0.00
Failed to give way or stop	23	23.47
Fatigue	0	0.00
Incorrect lanes or position	26	26.53
Miscellaneous factors	2	2.04
Overtaking	5	5.10
Pedestrian factors	7	7.14
Poor handling	8	8.16
Poor judgement	17	17.35
Poor observation	44	44.90
Position on Road	4	4.08
Road factors	4	4.08
Travel Speed	4	4.08
Unknown	0	0.00
Vehicle factors	1	1.02
Weather	0	0.00
TOTAL	157	160.20

## Drivers at fault or part fault in injury crashes - by age

Age	Male	Female	Unknown	Total	Percentage (%)
0-4	0	0	0	0	0.00
5-9	0	0	0	0	0.00
10-14	0	0	0	0	0.00
15-19	2	0	0	2	4.76
20-24	3	1	0	4	9.52
25-29	3	2	0	5	11.90
30-34	1	1	0	2	4.76
35-39	4	1	0	5	11.90
40-44	1	3	0	4	9.52
45-49	3	1	0	4	9.52
50-54	2	1	0	3	7.14
55-59	4	0	0	4	9.52
60-64	2	1	0	3	7.14
65-69	2	0	0	2	4.76
70-74	0	0	0	0	0.00
75-79	0	0	0	0	0.00
80-84	0	0	0	0	0.00
85-89	0	0	0	0	0.00
90-94	1	0	0	1	2.38

## Crashes with:

Factor groups	Crash numbers	% All crashes
All road user factors	24	24.49
Driver only factors	87	88.78
Pedestrian factors	7	7.14
Vehicle factors	1	1.02
Road factors	4	4.08
Environment factors	0	0.00
No identifiable factors	0	0.00
Retired codes - no future use	0	0.00
TOTAL	123	125.51

Notes: Factors are counted once against a crash - i.e. two fatigued drivers count as one fatigue crash factor.

Driver/vehicle factors are not available for non-injury crashes for Northland, Auckland, Waikato and Bay of Plenty before 2007. This will influence numbers and percentages.

% represents the % of crashes in which the cause factor appears.

## Number of parties in crash

Party type	All crashes	% All crashes
Single party	3	3.06
Multiple party, including pedestrian	16	16.33
Multiple party, excluding pedestrian	79	80.61
TOTAL	98	100

Age	Male	Female	Unknown	Total	Percentage (%)
95-99	0	0	0	0	0.00
100+	0	0	0	0	0.00
Unknown	0	0	3	3	7.14
TOTAL	28	11	3	42	-
Percent	66.67	26.19	7.14	100.00	-

Note: Driver information is not calculated for non-injury crashes.

## Drivers at fault or part fault in injury crashes - by licence

Licence	Male	Female	Unknown	Total	Percentage (%)
Full	19	7	0	26	61.90
Learner	0	0	0	0	0.00
Restricted	3	0	0	3	7.14
Overseas	0	2	0	2	4.76
Wrong class	0	0	0	0	0.00
Never Licensed	0	0	0	0	0.00
Unknown	6	2	3	11	26.19
Forbidden	0	0	0	0	0.00
TOTAL	28	11	3	42	-
Percent	66.67	26.19	7.14	100.00	-

Note: Driver information is not calculated for non-injury crashes.



## Vulnerable road users

Crash types	Number	Percentage (%)
Cyclist crashes	14	14.29
Pedestrian crashes	16	16.33
Motorcycle crashes	13	13.27
All other crashes	56	57.14

Note: Some crashes involve more than one vulnerable road user type.

Note: Motorcycle stats include Mopeds.

## Vehicles involved in injury crashes (vehicle count)

Vehicle type	No. of vehicles	% of vehicles in injury crashes
Unknown	0	0.00
Car/Wagon	28	41.18
SUV	2	2.94
Van	3	4.41
Ute	0	0.00
Truck	3	4.41
Truck HPMV	0	0.00
Bus	8	11.76
Motorcycle	6	8.82
Moped	4	5.88
Train	0	0.00
Cycle	14	20.59
Other	0	0.00
Unknown	0	0.00
50 Max	0	0.00
Left scene	0	0.00
Uncoupled towed vehicle	0	0.00
TOTAL	68	100.00

## Road environment statistics

### Road type

Road type	State highway	Local road	Unknown	N/A	Total	Percentage (%)
Urban	0	98	0	0	98	100.00
Open	0	0	0	0	0	0.00
Unknown	0	0	0	0	0	0.00
TOTAL	0	98	0	0	98	-
Percent	0.00	100.00	0.00	0.00	100.00	-

## Natural light conditions

Conditions	Injury	Non-injury	Total	%
Light/overcast	32	37	69	70.41
Dark/twilight	7	13	20	20.41
Unknown	0	9	9	9.18
TOTAL	39	59	98	100

## Conditions

Conditions	Injury	Non-injury	Total	%
Dry	32	41	73	74.49
Ice or Snow	0	0	0	0.00
Wet	7	12	19	19.39
Null	0	6	6	6.12
TOTAL	39	59	98	100

## Intersection/midblock

Intersection/mid-block	Total	%
Intersection	88	89.80
Midblock	10	10.20
TOTAL	98	100

## Vehicles involved in injury crashes (crash count)

Vehicle type	Injury crashes	% of injury crashes
Unknown	0	0.00
Car/Wagon	24	61.54
SUV	2	5.13
Van	3	7.69
Ute	0	0.00
Truck	3	7.69
Truck HPMV	0	0.00
Bus	7	17.95
Motorcycle	6	15.38
Moped	4	10.26
Train	0	0.00
Cycle	14	35.90
Other	0	0.00
Unknown	0	0.00
50 Max	0	0.00
Left scene	0	0.00
Uncoupled towed vehicle	0	0.00
TOTAL	63	161.54

## Objects struck

Objects struck	Injury crashes	%	Non-injury crashes	%
Crashes w/obj struck	5	5.10	21	21.43

Object struck	Injury crashes	%	Non-injury crashes	%
Animals	0	0.00	0	0.00
Bridges/Tunnels	0	0.00	0	0.00
Cliffs	0	0.00	0	0.00
Debris	0	0.00	0	0.00
Embankments	0	0.00	0	0.00
Fences	0	0.00	0	0.00
Guide/Guard rails	0	0.00	0	0.00
Houses	0	0.00	1	1.02
Traffic Islands	0	0.00	1	1.02
Street Furniture	0	0.00	0	0.00
Kerbing	0	0.00	2	2.04
Landslips	0	0.00	0	0.00
Parked vehicle	2	2.04	15	15.31
Trains	0	0.00	0	0.00
Sight Rails	0	0.00	0	0.00
Poles	0	0.00	1	1.02
Stationary Vehicle	3	3.06	2	2.04

## Vehicle usage in injury crashes

Vehicle usage	Fatal Crash	Serious Crash	Minor Crash	Total	Percentage (%)
Private	0	0	8	8	11.76
Attenuator Truck	0	0	0	0	0.00
Agricultural	0	0	0	0	0.00
Ambulance	0	0	0	0	0.00
Campervan	0	0	0	0	0.00
Concrete mixer	0	0	0	0	0.00
Fire	0	0	0	0	0.00
Logging truck	0	0	0	0	0.00
Mobile crane	0	0	0	0	0.00
Police	0	0	0	0	0.00
Rental	0	0	0	0	0.00
Road Working	0	0	0	0	0.00
Scheduled service Bus	0	0	1	1	1.47
School bus	0	0	0	0	0.00
Tanker	0	0	0	0	0.00
Taxi	0	0	3	3	4.41
Tour Bus	0	0	0	0	0.00
Trade person	0	0	0	0	0.00



Object struck	Injury crashes	%	Non-injury crashes	%
Roadwork	0	0.00	0	0.00
Traffic Sign	0	0.00	1	1.02
Trees	0	0.00	1	1.02
Drainage Structures	0	0.00	0	0.00
Ditches	0	0.00	0	0.00
Other	0	0.00	0	0.00
Thrown or dropped objects	0	0.00	0	0.00
Water	0	0.00	0	0.00
TOTAL	5	-	24	-

Note: % represents the % of crashes in which the object is struck.

Vehicle usage	Fatal Crash	Serious Crash	Minor Crash	Total	Percentage (%)
Work travel	0	0	0	0	0.00
Work vehicle	0	0	0	0	0.00
Other	0	0	0	0	0.00
Null	0	13	43	56	82.35
TOTAL	0	13	55	68	-
Percent	0.00	19.12	80.88	100.00	-

### Time period statistics

## Month by injury/ non-injury crashes

Month	Injury crashes	%	Non-injury crashes	%	Total	%
Jan	4	10.26	6	10.17	10	10.2
Feb	5	12.82	5	8.47	10	10.2
Mar	4	10.26	4	6.78	8	8.16
Apr	2	5.13	6	10.17	8	8.16
May	6	15.38	6	10.17	12	12.24
Jun	6	15.38	5	8.47	11	11.22
Jul	3	7.69	3	5	6	6.12
Aug	3	7.69	5	8.47	8	8.16
Sep	1	2.56	3	5	4	4
Oct	2	5.13	9	15.25	11	11.22
Nov	3	7.69	6	10.17	9	9.18
Dec	0	0	1	1.69	1	1
TOTAL	39	100	59	100	98	100

## Day/period

Day/Period	All crashes	% All crashes
Weekday	81	82.65
Weekend	17	17.35
TOTAL	98	100

### Day/period by hour

	00:00 -	03:00 -	06:00 -	09:00 -	12:00 -	15:00 -	18:00 -	21:00 -	
Day/Period	02:59	05:59	08:59	11:59	14:59	17:59	20:59	23:59	Total
Weekday	0	0	17	11	20	23	8	1	80
Weekend	2	1	0	1	3	2	3	5	17
TOTAL	2	1	17	12	23	25	11	6	97



### Day/period by hour DOW

	00:00 -	03:00 -	06:00 -	09:00 -	12:00 -	15:00 -	18:00 -	21:00 -	
Day/Period	02:59	05:59	08:59	11:59	14:59	17:59	20:59	23:59	Total
Mon	0	1	4	1	2	7	0	0	15
Tue	0	0	3	2	3	4	1	1	14
Wed	0	0	4	3	2	0	3	0	12
Thu	0	0	4	4	5	5	4	0	22
Fri	0	0	2	1	8	7	2	4	24
Sat	1	0	0	0	1	1	1	1	5
Sun	1	0	0	1	2	1	0	0	5
TOTAL	2	1	17	12	23	25	11	6	97



# Appendix B - AS/NZS 2890.6 References

**TABLE 1.1**  
**CLASSIFICATION OF OFF-STREET CAR PARKING FACILITIES**

User class	Required door opening	Required aisle width	Examples of uses (Note 1)
1	Front door, first stop	Minimum for single manoeuvre entry and exit	Employee and commuter parking (generally, all-day parking)
1A	Front door, first stop	Three-point turn entry and exit into 90° parking spaces only, otherwise as for User Class 1	Residential, domestic and employee parking
2	Full opening, all doors	Minimum for single manoeuvre entry and exit	Long-term city and town centre parking, sports facilities, entertainment centres, hotels, motels, airport visitors (generally medium-term parking)
3	Full opening, all doors	Minimum for single manoeuvre entry and exit	Short-term city and town centre parking, parking stations, hospital and medical centres
3A	Full opening, all doors	Additional allowance above minimum single manoeuvre width to facilitate entry and exit	Short term, high turnover parking at shopping centres
4	Size requirements are specified in AS/NZS 2890.6 (Note 2)		Parking for people with disabilities

Figure 42: Table 1.1 of AS/NZS 2890.1: 2004 Figure 2.2

AS/NZS 2890.1:2004

24

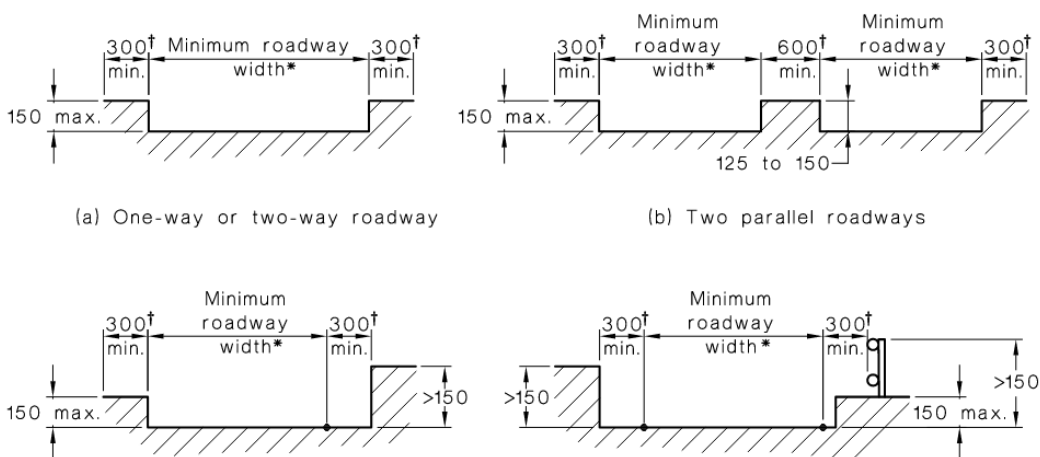

(a) One-way or two-way roadway (b) Two parallel roadways (c) High obstruction on one side of roadway (d) High obstruction on both sides of roadway

\* Minimum roadway width: One-way roadway—3000 mm  
Two-way roadway—5500 mm  
On curve—see Table 2.2

† Increase clearance to 500 mm if on the outside of a curve.

DIMENSIONS IN MILLIMETRES

FIGURE 2.8 CIRCULATION ROADWAY AND RAMP CROSS SECTIONS

Figure 43: AS/NZS 2890.1: 2004 Figure 2.8



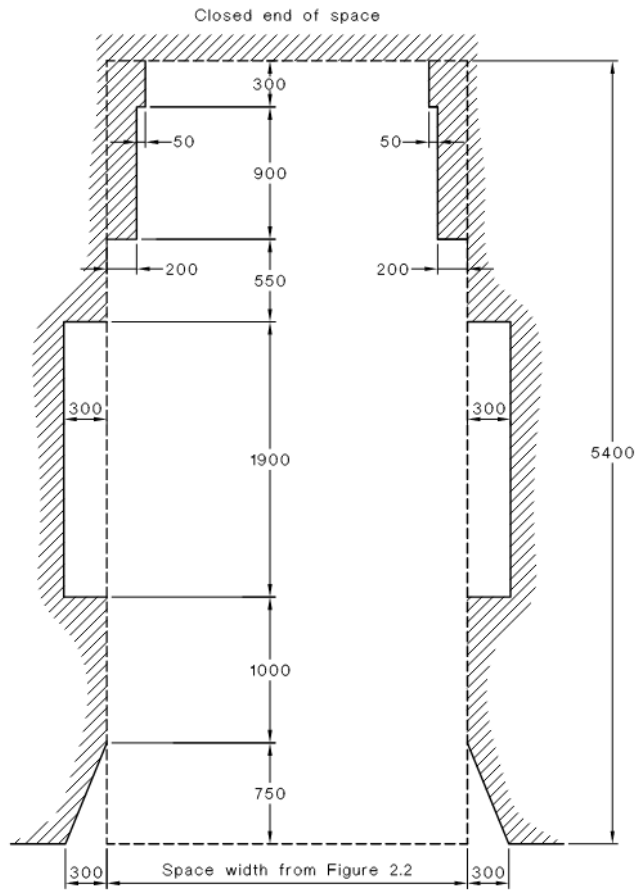

NOTE: The design envelope provides for structural elements to be clear of all four side doors.

Figure 44: AS/NZS 2890.1: 2004 Figure 5.2

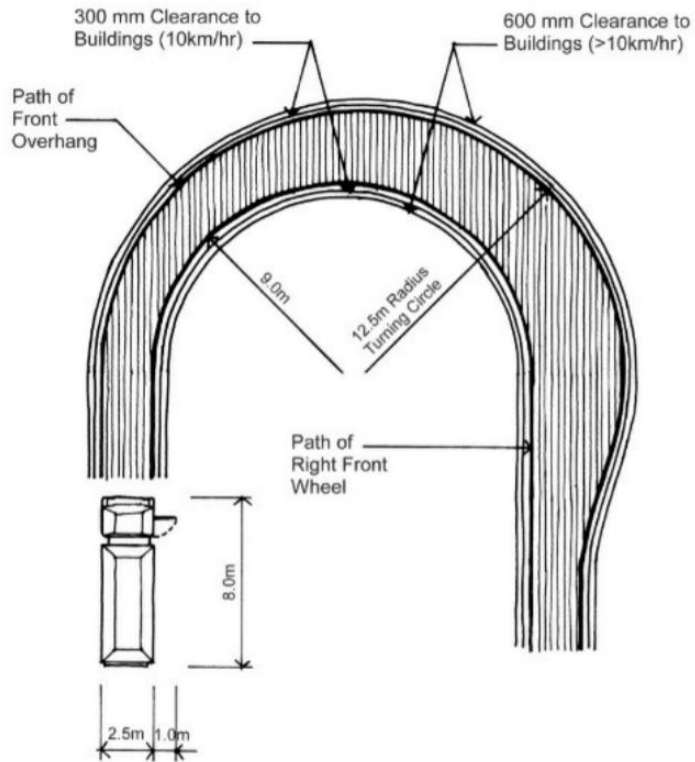
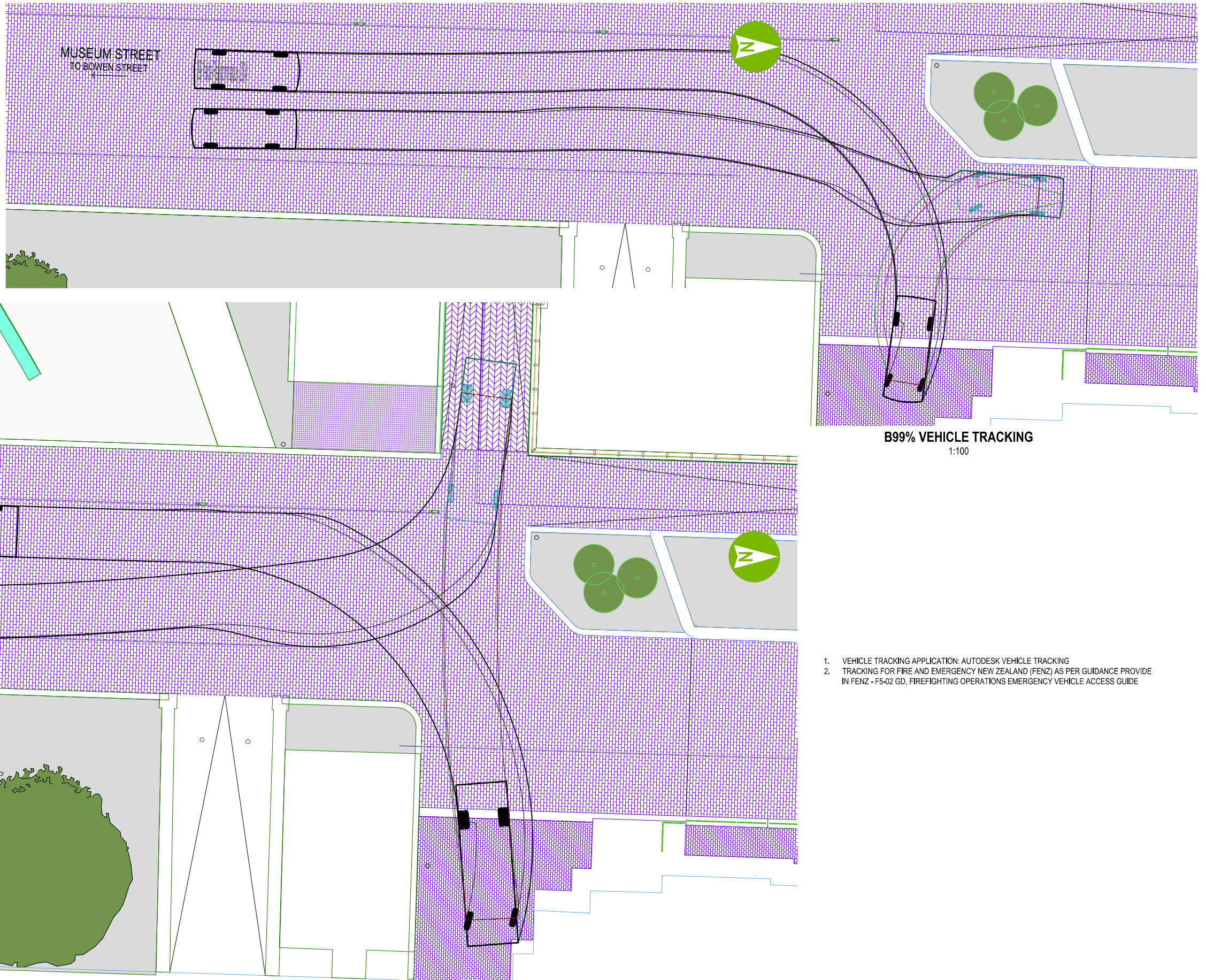

Figure 45: Turning Path of Medium Rigid Vehicle

# Appendix C – Tracking Analysis



**B99% VEHICLE TRACKING**  
1:100

**8m MEDIUM RIGID VEHICLE (FENZ VEHICLE TYPE 1,2,3)**  
1:100

1. VEHICLE TRACKING APPLICATION: AUTODESK VEHICLE TRACKING
2. TRACKING FOR FIRE AND EMERGENCY NEW ZEALAND (FENZ) AS PER GUIDANCE PROVIDED IN FENZ - F5-02 GD, FIREFIGHTING OPERATIONS EMERGENCY VEHICLE ACCESS GUIDE



File Date: 28/02/2023 11:17:42 AM    Client: Auckland    Filename: C:\USERS\STUART.HAMILTON\AURECON\PROJECTS\PARLIAMENT\_FAS\PROJECT FILES\AURECON\CIVIL\DRAWINGS\255585\0001\_SKT\_RR\001.DWG



REV	DATE	REVISION DETAILS	APPROVED
A		CONCEPT DESIGN	M. WELBY

SCALE	SIZE
1:100	A1
<b>DRAWN</b>	S.HAMILTON
<b>DESIGNED</b>	S.HAMILTON
<b>CHECKED</b>	-

INFORMATION	APPROVED
NOT FOR CONSTRUCTION	DATE

PROJECT	PARLIAMENT FUTURE ACCOMMODATION STRATEGY (FAS)
TITLE	VEHICLE TRACKING MUSEUM STREET
DRAWING No.	255585 - 0600 - SKT - RR - 0001 - B



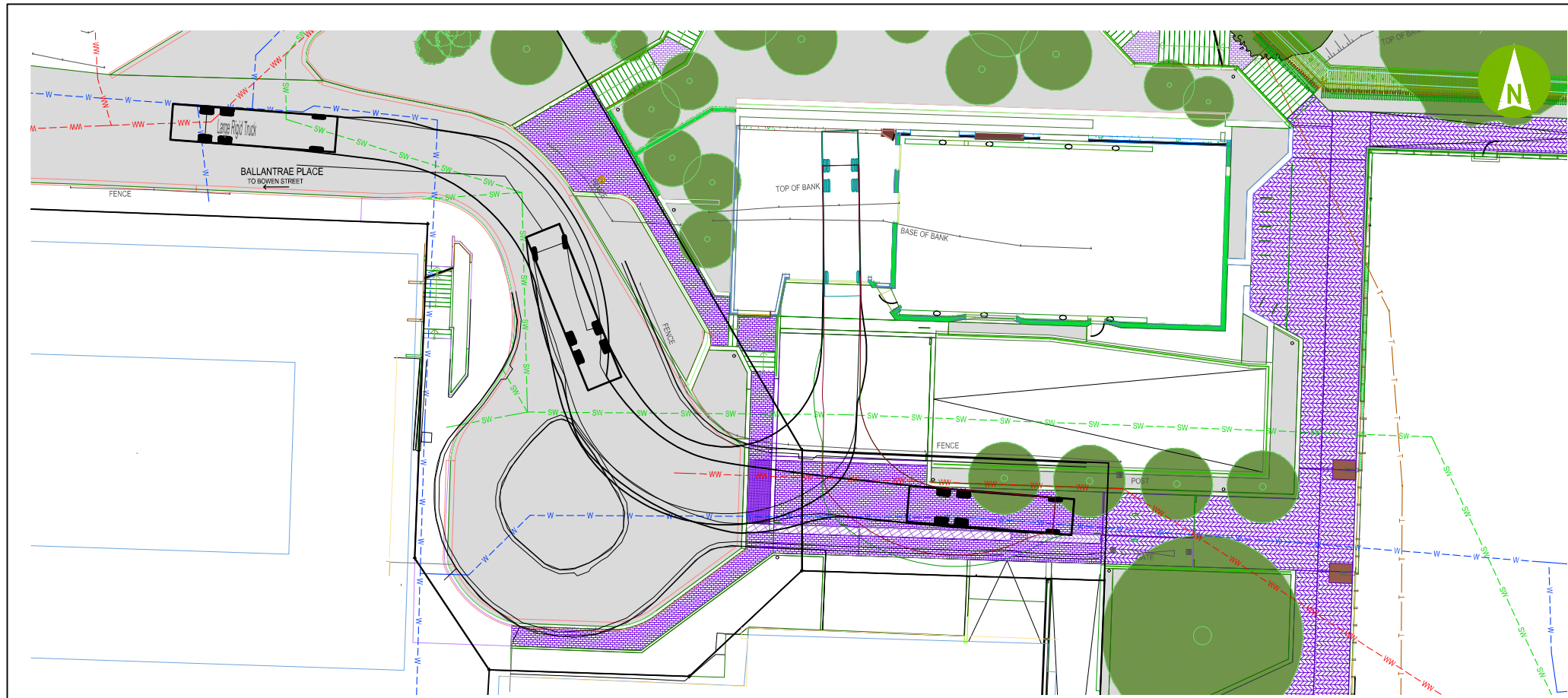

RTS 18 - LARGE RIGID VEHICLE (11.5m)

1:200

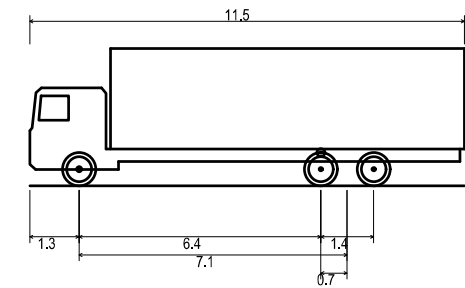

Large Rigid Truck  
 Overall Length 11.500m  
 Overall Width 2.500m  
 Overall Body Height 3.632m  
 Min Body Ground Clearance 0.427m  
 Track Width 2.500m  
 Lock-to-lock time 6.00s  
 Wall to Wall Turning Radius 12.000m

1. VEHICLE TRACKING APPLICATION: AUTODESK VEHICLE TRACKING.
2. VEHICLE DIMENSIONS BASED ON WAKA KOTAHU NZ TRANSPORT AGENCY VEHICLE DIMENSIONS AND MASSES.
3. TRACKING FOR FIRE AND EMERGENCY NEW ZEALAND (FENZ) AS PER GUIDANCE PROVIDED IN FENZ - F5-02 GD, FIREFIGHTING OPERATIONS EMERGENCY VEHICLE ACCESS GUIDE

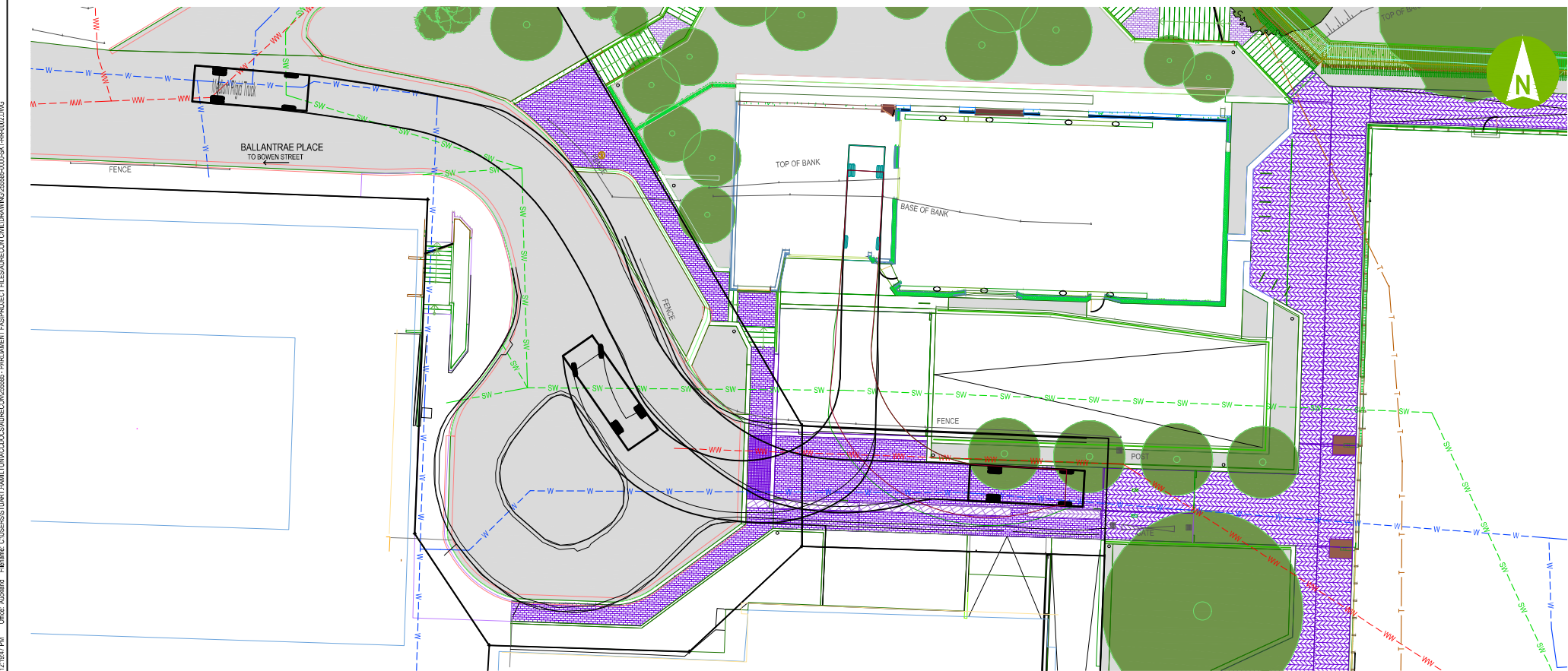

RTS 18 - MEDIUM RIGID VEHICLE (8.0m) - REVERSE ENTRY

1:200

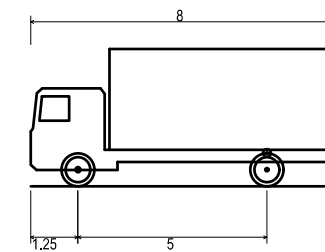

Medium Rigid Truck  
 Overall Length 8.000m  
 Overall Width 2.500m  
 Overall Body Height 3.632m  
 Min Body Ground Clearance 0.427m  
 Track Width 2.500m  
 Lock-to-lock time 6.00s  
 Wall to Wall Turning Radius 10.000m



File Path: C:\Users\stuart.hamilton\Documents\Aurecon\255585\_Parliament Future Project\255585\_Parliament Future Project\255585\_SKT\_RR\_0002.DWG  
 Date: 23/03/2021 12:38:47 PM  
 Office: Auckland



REV	DATE	REVISION DETAILS	APPROVED	SCALE	SIZE
A		CONCEPT DESIGN	M. WELBY	1:100	A1

DRAWN	S.HAMILTON
DESIGNED	S.HAMILTON
CHECKED	

INFORMATION	APPROVED
NOT FOR CONSTRUCTION	DATE

PROJECT	PARLIAMENT FUTURE ACCOMMODATION STRATEGY (FAS)
TITLE	VEHICLE TRACKING SERVICES BUILDING
DRAWING No.	255585 - 0600 - SKT - RR - 0002 - A



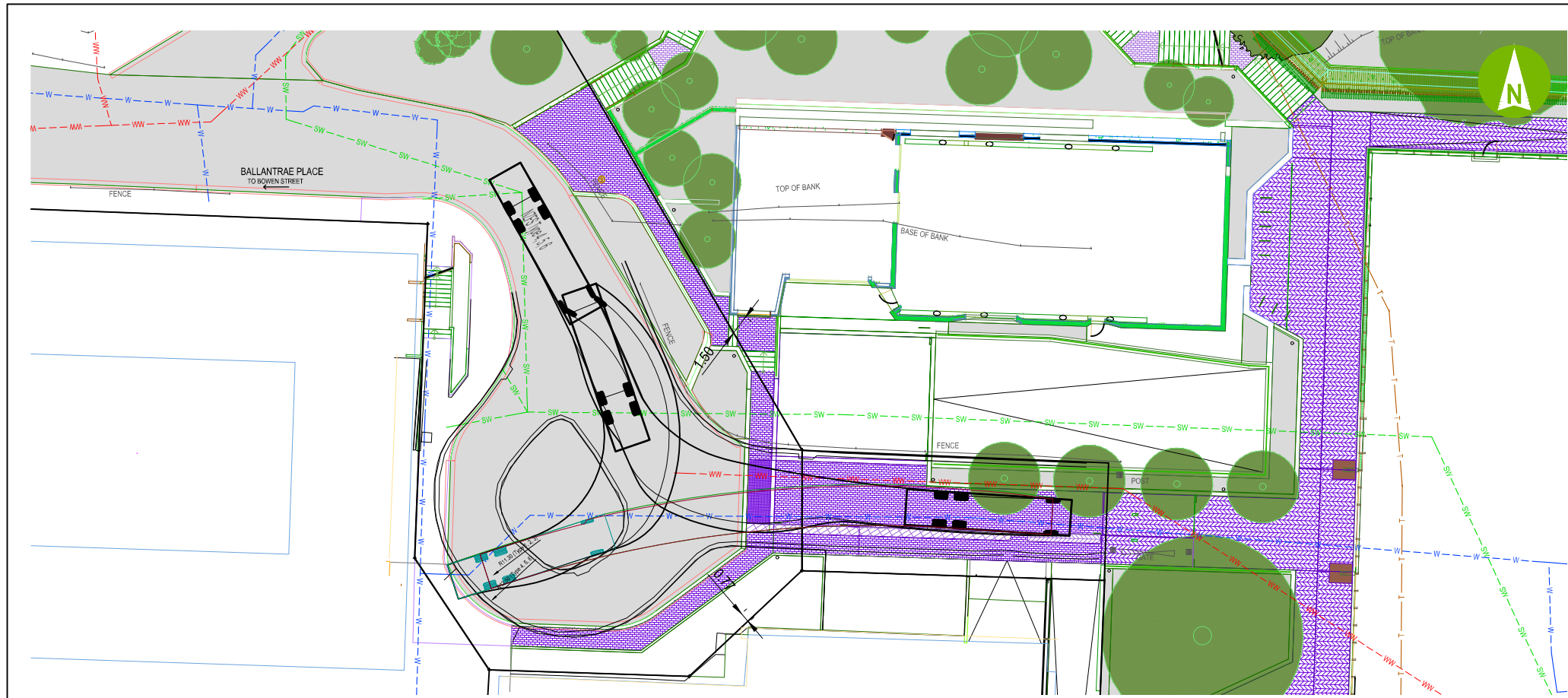

FENZ TYPE 4,5,6 APPLIANCE (RTS 18 LARGE RIGID VEHICLE)

1:200

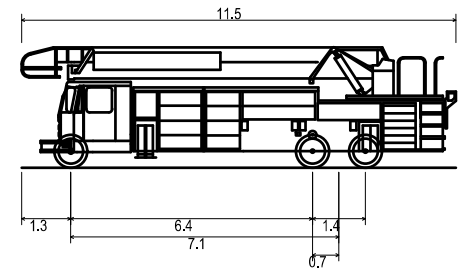

NZFS Type 4, 5, 6  
 Overall Length 11.500m  
 Overall Width 2.500m  
 Overall Body Height 3.190m  
 Min Body Ground Clearance 0.274m  
 Track Width 2.500m  
 Lock-to-lock time 6.00s  
 Wall to Wall Turning Radius 12.000m

1. VEHICLE TRACKING APPLICATION: AUTODESK VEHICLE TRACKING.
2. VEHICLE DIMENSIONS BASED ON WAKA KOTAHI NZ TRANSPORT AGENCY VEHICLE DIMENSIONS AND MASSES.
3. TRACKING FOR FIRE AND EMERGENCY NEW ZEALAND (FENZ) AS PER GUIDANCE PROVIDED IN FENZ - F5-02 GD, FIREFIGHTING OPERATIONS EMERGENCY VEHICLE ACCESS GUIDE



FENZ TYPE 4,5,6 APPLIANCE (RTS 18 LARGE RIGID VEHICLE)

1:200



File Date: 23/02/2021 12:28:28 PM    Office: Auckland    Filename: C:\Users\stuart.hamilton\Documents\Aurecon\255585\_Parliament Future Project\TLE\Aurecon\Civil\Drawings\255585\_0003\_SKT\_RR\_0003.DWG



REV	DATE	REVISION DETAILS	APPROVED	SCALE	SIZE
A		CONCEPT DESIGN	M. WELBY	1:100	A1

DRAWN	S.HAMILTON
DESIGNED	S.HAMILTON
CHECKED	

INFORMATION	
NOT FOR CONSTRUCTION	
APPROVED	DATE

PROJECT	PARLIAMENT FUTURE ACCOMMODATION STRATEGY (FAS)				
TITLE	VEHICLE TRACKING SERVICES BUILDING				
DRAWING No.	PROJECT No.	WBS	TYPE	DISC-NUMBER	REV
	255585	0600	SKT - RR	0003	A

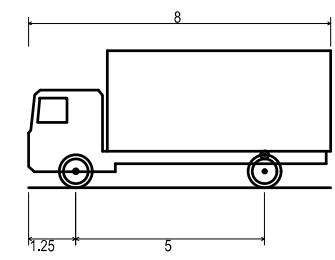
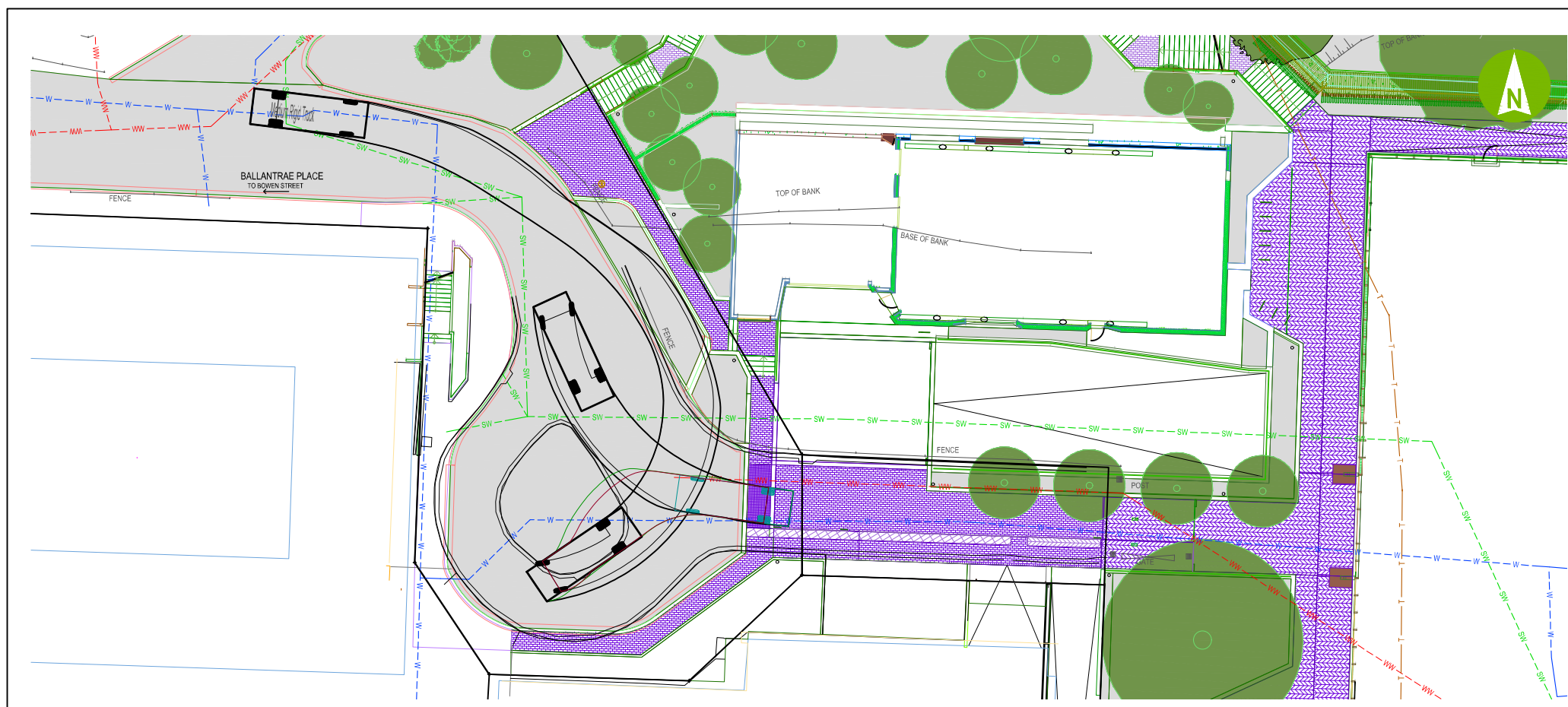

Medium Rigid Truck  
 Overall Length 8.000m  
 Overall Width 2.500m  
 Overall Body Height 3.632m  
 Min Body Ground Clearance 0.427m  
 Track Width 2.500m  
 Lock-to-lock time 6.00s  
 Wall to Wall Turning Radius 10.000m

1. VEHICLE TRACKING APPLICATION: AUTODESK VEHICLE TRACKING.
2. VEHICLE DIMENSIONS BASED ON WAKA KOTAHI NZ TRANSPORT AGENCY VEHICLE DIMENSIONS AND MASSES.
3. TRACKING FOR FIRE AND EMERGENCY NEW ZEALAND (FENZ) AS PER GUIDANCE PROVIDE IN FENZ - F5-02 GD, FIREFIGHTING OPERATIONS EMERGENCY VEHICLE ACCESS GUIDE

**RTS 18 - MEDIUM RIGID VEHICLE (8.0m)**  
 1:200



File Date: 23/02/2021 12:21:00 PM | Client: Auckland | File Name: C:\Users\stuart.hamilton\Documents\AURECON\CON\DRAWING\255585\0005\SKT-RR-0004.DWG



REV	DATE	REVISION DETAILS	APPROVED
A		CONCEPT DESIGN	M. WELBY

SCALE	SIZE
1:100	A1
<b>DRAWN</b>	
S.HAMILTON	
<b>DESIGNED</b>	
S.HAMILTON	
<b>CHECKED</b>	
-	

INFORMATION
NOT FOR CONSTRUCTION
<b>APPROVED</b>
DATE
-

PROJECT	PARLIAMENT FUTURE ACCOMMODATION STRATEGY (FAS)
TITLE	VEHICLE TRACKING SERVICES BUILDING
DRAWING No.	255585 - 0600 - SKT - RR - 0004 - A



# Appendix D – Traffic Counts

## Museum Street

The Museum Street, Bowen Street and The Terrace intersection was monitored from 7.30am to 5.30pm on Wednesday the 9th of June. Focus was placed on monitoring vehicle entry and egress movements from Museum Street from and into the intersection for staff, visitors and service vehicles. Service vehicles were considered to include courier vehicles, vans and trucks. Observed traffic counts are provided in Table 7 below.

*Note: The “longest queue length” for left turn entry movements, and exit movement from Museum Street is generally blank, as vehicles were observed to change lanes to pass vehicles attempting to turn mitigating the need for queueing.*

**Table 7: Traffic Counts Museum Street/Bowen Street/The Terrace Intersection**

Time Interval (15mins)	Right turn in from Bowen St		Longest Queue Length	Left turn in from Bowen St		Longest Queue Length	Straight through (from The Terrace)		Right turn out from Museum Street		Longest Queue Length	Left turn out from Museum Street		Longest Queue Length	Straight through (to The Terrace)	
	Standard Veh	Service Veh		Standard Veh	Service Veh		Standard Veh	Service Veh	Standard Veh	Service Veh		Standard Veh	Service Veh		Standard Veh	Service Veh
7:30am	2	1	3	2	2		1	1		1		1				1
7:45am				1			2	1								1
8:00am	6		4	4	1		2					3	1			
8:15am				2			1					2	1			1
8:30am	2	2	10	2			2					3				
8:45am	6		4	1			1		1			2				1
9:00am		2		1	1		2	1				3	2			
9:15am				1			1					2	2			
9:30am	3	1	3	2			1					3	1			
9:45am								1								
10:00am	2			1			1					4	1		1	1

10:15am	1											2				
10:30am		4	2		1								1			
10:45am	1				1			1								
11:00am	1	3	3	1	1							1	3			1
11:15am		1					1		1			1	2			
11:30am	1	2		1			1						4			
11:45am	2	2		1	2		2	2				2	1		1	
12:00pm	2	1						1		2		3	2			
12:15pm	1	1		1			2					2	1		1	
12:30pm				2	1		1	1		1			2			
12:45pm	1	2			2		1	1				2	3			
1:00pm	1			2	1		1					3	1		1	1
1:15pm	2	3	3	1				1				4	2			
1:30pm		4		2				1	1			2	1			
1:45pm	1							1				2	5			1
2:00pm	2	1		2				1	1	1		1	1			
2:15pm	1									1		2				
2:30pm	2	2	2	2						1		1				
2:45pm	1	1								1						
3:00pm				1						1		8			1	
3:15pm	2		5	1								5	2		1	
3:30pm	1	1		1				1	2			5				1
3:45pm	1							1				6				1
4:00pm		1		2				1				3	2			



4:15pm				1			1					1	2			
4:30pm	1			1				1	1			3	1			
4:45pm	1											1				
5:00pm		1			1				1	1		3	2			
5:15pm				1								4				
<b>Total</b>	<b>47</b>	<b>36</b>	<b>-</b>	<b>40</b>	<b>14</b>	<b>-</b>	<b>30</b>	<b>16</b>	<b>9</b>	<b>5</b>	<b>-</b>	<b>90</b>	<b>46</b>	<b>-</b>	<b>6</b>	<b>10</b>

## Observations of Significance

Observations related to the safety and functionality of the intersection are provided in Table 8 below.

**Table 8: Site Observations**

Time	Observation
<b>7:53am</b>	A service vehicle went straight out of Museum Street to The Terrace. The light was green for vehicles that were going down Bowen street (towards Lambton Quay), and the cars had to stop to allow the service vehicle through.
<b>7:47am</b>	A taxi drove straight into Museum Street from the Terrace and a pedestrian wasn't looking up. The taxi had to slow right down within the intersection, and the pedestrian had to stop to let the taxi through.
<b>8:14am</b>	A taxi turned right into Museum Street from Bowen Street. Due to crossing pedestrians the vehicle had to stop in the middle of the intersection, and an eastbound car travelling along Bowen Street had to stop suddenly.
<b>8:18am</b>	A cyclist was turning right out of The Terrace onto Bowen Street, and another cyclist was turning right from Bowen onto Museum Street. The cyclists were very close to colliding and both braked very suddenly.
<b>8:22am</b>	Pedestrians crossing from The Terrace to Museum Street cut straight across to Museum Street, crossing through a lane of traffic, which had to stop.
<b>8:46am</b>	A vehicle was turning right out of Museum Street and the pedestrian crossing went green. The turning car had to stop in the middle of the intersection.
<b>1:08pm</b>	Pedestrian crossed Bowen Street, on opposite side of the intersection to the actual crossing. A service van turned left out of Museum Street and had to stop in the intersection to allow the pedestrian to finish crossing.
<b>1:28pm</b>	A car turned right into Museum Street in front of a car heading the opposite direction down Bowen Street resulting in a near miss collision.
<b>4:53pm</b>	A car turned into Museum Street, and then completed a 3-point turn. This was done by reversing back out into the middle of the intersection.

## Ballantrae Place

The Ballantrae Place and Bowen Street intersection was monitored for 4 hours on Wednesday 9th June 2021. Only standard peak periods were monitored; between 7:30am – 9:15am and 4pm – 5:30pm. Focus was placed on vehicle movements into/from Ballantrae Place from/to Bowen Street.

Table 9: Traffic Counts Bowen Street/Ballantrae Place Intersection

	Right turn in from Bowen Ave	Longest Queue Length	Left turn in from Bowen Ave	Longest Queue Length	Right turn out from Ballantrae	Longest Queue Length	Left turn out from Ballantrae	Longest Queue Length
	<b>Entry Movements</b>				<b>Exit Movements</b>			
7:30am	11	3	47	3	5	2	6	2
7:45am	11	3	30	2	3	2	9	2
8:00am	12	3	34	5	6	2	8	2
8:15am	15	4	35	10	2	2	15	2
8:30am	12	4	27	5	1	1	5	1
8:45am	12	2	26	4	3	1	12	3
9:00am	10	2	28	2	4	1	8	3
4:00pm	6		9		16	3	15	2
4:15pm	13	2	8		20	3	22	
4:30pm	7		3		14	2	19	5
4:45pm	5		5		25	3	12	
5:00pm	8		5		25	5	20	3
5:15pm	4		8		23	3	19	3
<b>Sub- total</b>	<b>126</b>		<b>265</b>		<b>147</b>		<b>170</b>	

## Observations of Significance

- Traffic counters observed free un-congested westbound vehicle through movements along Bowen Street.

- Roadworks were being undertaken along Bowen Street in vicinity of the Parliamentary Precinct at the time of undertaken traffic counts. Due to ongoing roadworks, a temporary bus stop has been placed near the Ballantrae Place/Bowen Street intersection. Road stoppages also occurred during the traffic counts.
- Traffic counters observed U-turn movements being undertaken in vicinity of the Bowen Street/Ballantrae Place intersection. The majority of U-turn movements was undertaken at Location 1 along Bowen Street as shown in Figure 46 below.

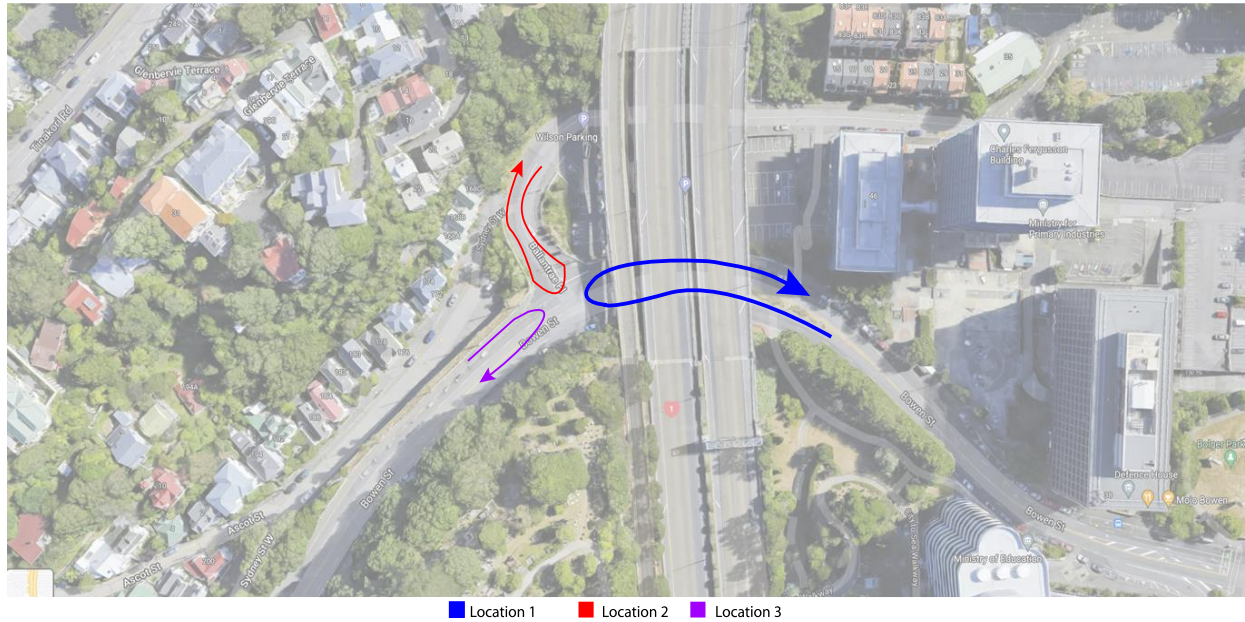

**Figure 46: U-turn movements observed**

## Appendix E – Trip Generation Assessment

The existing and proposed GFA of the project site is as detailed in Table 10 below.

**Table 10: Existing and Proposed Site GFA**

Existing GFA (m <sup>2</sup> )	Proposed GFA (m <sup>2</sup> )
<ul style="list-style-type: none"> <li>Executive Wing: approximately 25,300m<sup>2</sup></li> </ul>	<ul style="list-style-type: none"> <li>Executive Wing: approximately 25,300m<sup>2</sup></li> </ul>
<ul style="list-style-type: none"> <li>Parliament House: approximately 22,650m<sup>2</sup></li> </ul>	<ul style="list-style-type: none"> <li>Parliament House: approximately 22,650m<sup>2</sup></li> </ul>
<ul style="list-style-type: none"> <li>Parliamentary Library: approximately 7,750 m<sup>2</sup></li> </ul>	<ul style="list-style-type: none"> <li>Parliamentary Library: approximately 7,750m<sup>2</sup></li> </ul>
	<ul style="list-style-type: none"> <li>Future Museum Street Building: approximately 9,150m<sup>2</sup></li> </ul>
	<ul style="list-style-type: none"> <li>Future Ballantrae Place Building: approximately 1,000m<sup>2</sup></li> </ul>
<b>Total: 55,700m<sup>2</sup></b>	<b>Total: 65,850 m<sup>2</sup> (represents an increase of 10,150m<sup>2</sup>)</b>

Research Report 453<sup>7</sup> does not provide trip generation rates specific to Parliamentary style activities. Therefore, trip generation rates for an Office Activity have been used as this activity most closely resembles the travel characteristics of the project site.

**Research Report 453:** Table 7.4 indicates that for Office activities, the peak hour trip generation rate is 2.5 trips per 100m<sup>2</sup> GFA and the daily trip generation rate is 26.1 trips per 100m<sup>2</sup> GFA. Table 11 indicates the existing and proposed trips generated in accordance with the above trip generation rates.

**Table 11: Potential Trip Generation**

	Peak Hour Trip Generation	Daily Trip Generation
<b>Trip Generation Rate</b>	<i>2.5 trips per 100m<sup>2</sup> GFA</i>	<i>26.1 trips per 100m<sup>2</sup> GFA</i>
Existing GFA (m <sup>2</sup> ) of 55,700m <sup>2</sup>	1393 trips	14538 trips
Proposed GFA (m <sup>2</sup> ) of 65,850 m <sup>2</sup>	1646 trips	17187trips
<b>Potential Increase</b>	<b>25 trips</b>	<b>2649 trips</b>

The trip rates reflected in Table 11 above, are based on surveys undertaken at four commercial office activities located in New Zealand. The timing of these surveys (potentially outdated), the location of observed commercial activities (potentially areas with low accessibility via active/sustainable modes), and the scale of the project site compared to standard office activities, results in the above trip generation rates likely being highly inaccurate. The predicated trips generated by the existing site GFA are also inconsistent with observations / vehicle volumes noted during undertaken traffic counts.

<sup>7</sup> Research Report 453 provides a comprehensive national database of information on trips and parking related to land use in New Zealand and identifies historic trip trends since the 1970s.



# Appendix F – Resource Consent ITA RFI Response

# Memorandum

To	<b>Peter Coop</b>	From	<b>Sheyah Ballinger</b>
Copy	<b>Malcolm Tait, Marcus Welby, Michael Davis, Blair Brixton.</b>	Reference	<b>255585</b>
Date	<b>2022-06-13</b>	Pages (including this page)	<b>2</b>
Subject	<b>Resource Consent ITA RFI Response</b>		

SR514663

The Council has requested additional information to enable a full assessment of the potential traffic affects as part of the resource consent. Please find below the original queries and the design team responses:

<p>1. The Integrated Transport Assessment has provided tracking curves for the turning area for a large (99 percentile) vehicle at the north end of Museum Street. It is recommended that the location of this turning area is highlighted and clarified on the relevant architectural plans, e.g. the “Detail Plan – Southern Museum Street” (P A2-10) or “Detail Plan – Northern Museum Street” (P A2-11).</p>	<p>Refer to the updated attached drawing for the Museum Street vehicle tracking:</p> <ul style="list-style-type: none"> <li>• 255585-0600-SKT-RR-0001-2006 (VEHICLE TRACKING MUSEUM STREET - B99 PERCENTILE VEHICLE)</li> <li>• 255585-0600-SKT-RR-0001-2005 (VEHICLE TRACKING MUSEUM STREET – LARGE RIGID TRUCK)</li> </ul>
<p>2. The Integrated Transport Assessment indicates that the service vehicles will turn around using the end of Ballantrae Place as a turning area and has provided tracking curves for a large truck and a medium truck entering the servicing area in the BAL building. However, these show that the vehicle would need to track over the central island at the end of Ballantrae Place. Please clarify if any changes are needed to the layout of Ballantrae Place.</p>	<p>As part of this project the geometries of Ballantrae Place will be improved for vehicle turning. A pre-app meeting was held on Mon. 14. March 2022 with WCC to discuss these Ballantrae improvements. The current design is a low-profile island which is traversed by HGV vehicles.</p> <p>In the proposed design improvements, the island would be omitted, reduced or made flush to facilitate movements, also no 3D obstructions to tracking are included to allow for FENZ access over kerbs as required. Please refer to attached drawings:</p> <ul style="list-style-type: none"> <li>• 255585-0600-SKT-RR-0001-2010</li> <li>• 255585-0600-SKT-RR-0001-2009</li> <li>• 255585-0600-SKT-RR-0001-2011</li> <li>• 255585-0600-SKT-RR-0001-2003</li> <li>• 255585-0600-SKT-RR-0001-2004</li> </ul>
<p>3. The tracking curves for the BAL building also indicate that they may need to pass over what could</p>	<p>A barrier arm will be provided along the entrance/exit to the basement ramp. Trucks (both medium-rigid and large-rigid) are</p>

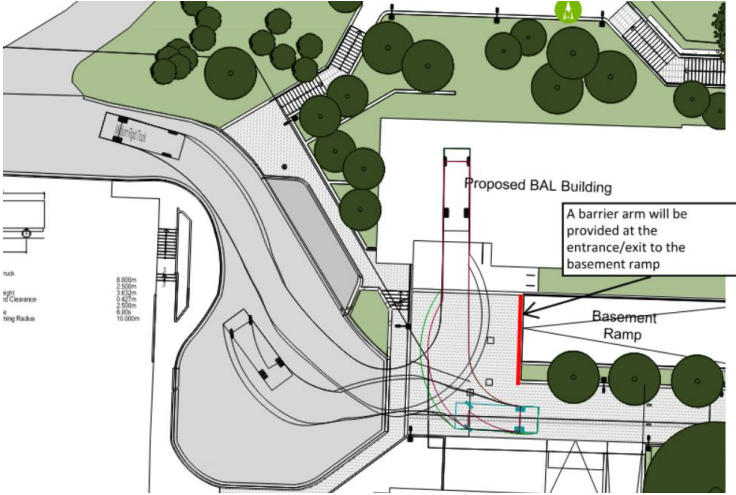
<p>be a “vehicle barrier arm” near the western end of the basement ramp. Similarly, the architectural plan “Illustrative View H – Ballantrae Place” (P A6-13) appears to indicate a barrier near the top of the vehicle ramp to the basement. Can this please be clarified.</p>	<p>able to enter and egress into the Bal Place loading area without infringing upon the barrier arm.</p> <p>Please refer to attached drawings:</p> <ul style="list-style-type: none"> <li>• 255585-0600-SKT-RR-0001-2010</li> <li>• 255585-0600-SKT-RR-0001-2009</li> </ul> 
<p>4. Please advise whether service vehicles need close access and parking for the Wastewater Heat Recovery building near the BAL building. If so, please advise how this will be provided.</p>	<p>Please note that there will no longer be a wastewater heat recovery unit as part of this project. This will no longer be an issue.</p>
<p>5. It is assumed that the heritage gates on Museum Street will generally remain open and that access will be controlled by the row of bollards, but this should be confirmed. There are currently driveways at the eastern end of the upper carpark that appear to provide vehicle access to near the western side of the Parliamentary Library. Please advise whether this access is intended to be retained.</p>	<p>5.1 The intention is that the heritage gates at the Museum Street entrance will primarily remain open unless required to be closed – in a security event. Note that while these gates are open access to the precinct will primarily be Ballantrae PI to minimize traffic conflict between Museum St and the Bowen St intersection.</p> <p>5.2 The vehicle access dock way on the western side of Parliamentary Library is intended to be retained for occasional use or delivery of large items.</p>

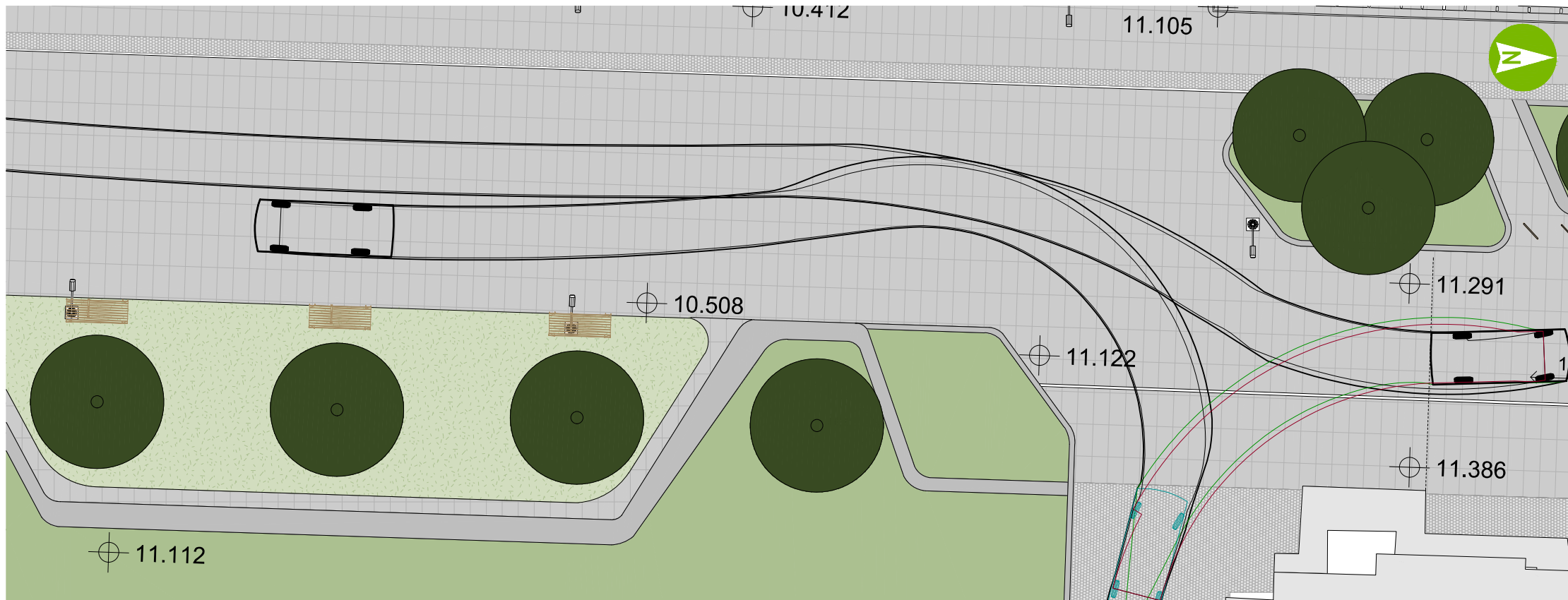

**B99% VEHICLE TRACKING**  
1:100

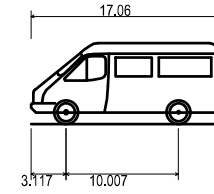

**B99 Vehicle (8m min radius) (2004)**  
 Overall Length  
 Overall Width  
 Overall Body Height  
 Min Body Ground Clearance  
 Track Width  
 Lock-to-lock time  
 Curb to Curb Turning Radius

17.060ft  
 6.365ft  
 7.218ft  
 1.024ft  
 6.037ft  
 4.00s  
 26.247ft

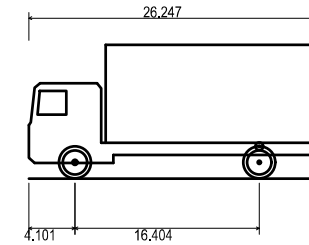

**Medium Rigid Truck**  
 Overall Length  
 Overall Width  
 Overall Body Height  
 Min Body Ground Clearance  
 Track Width  
 Lock-to-lock time  
 Wall to Wall Turning Radius

26.247ft  
 8.202ft  
 11.916ft  
 1.403ft  
 8.202ft  
 6.00s  
 32.808ft

1. VEHICLE TRACKING APPLICATION: AUTODESK VEHICLE TRACKING
2. TRACKING FOR FIRE AND EMERGENCY NEW ZEALAND (FENZ) AS PER GUIDANCE PROVIDED IN FENZ - F5-02 GD, FIREFIGHTING OPERATIONS EMERGENCY VEHICLE ACCESS GUIDE

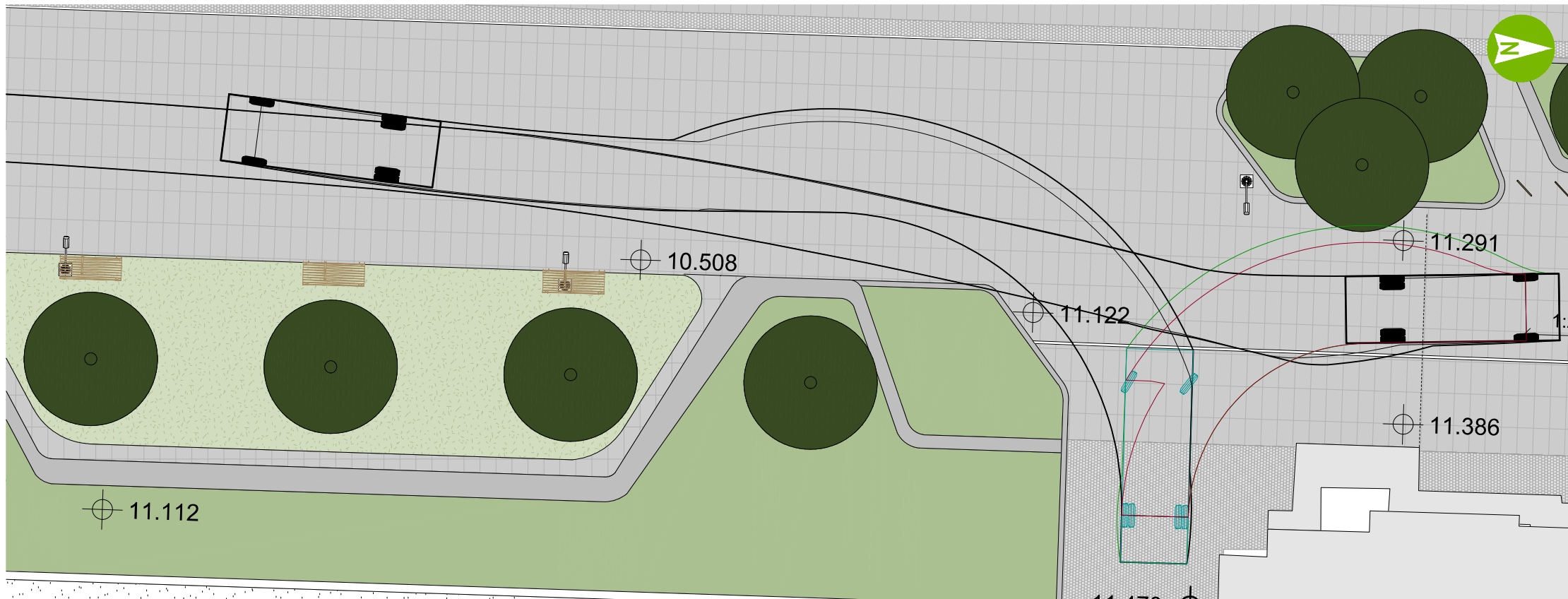

**8m MEDIUM RIGID VEHICLE (FENZ VEHICLE TYPE 1,2,3)**  
1:100

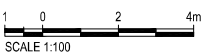

REV	DATE	REVISION DETAILS	APPROVED
A		CONCEPT DESIGN	M. WELBY

SCALE	SIZE
1:100	A1
<b>DRAWN</b>	
S.HUNSEMAKKI	
<b>DESIGNED</b>	
S.HUNSEMAKKI	
<b>CHECKED</b>	
S.HAMILTON	

INFORMATION
NOT FOR CONSTRUCTION
<b>APPROVED</b>
DATE

PROJECT	PARLIAMENT FUTURE ACCOMMODATION STRATEGY (FAS)
TITLE	VEHICLE TRACKING MUSEUM STREET
DRAWING No.	255585
PROJECT No.	0600
WBS	SKT
TYPE	RR
DISC-NUMBER	0005
REV	A



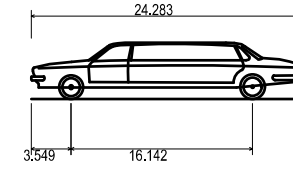
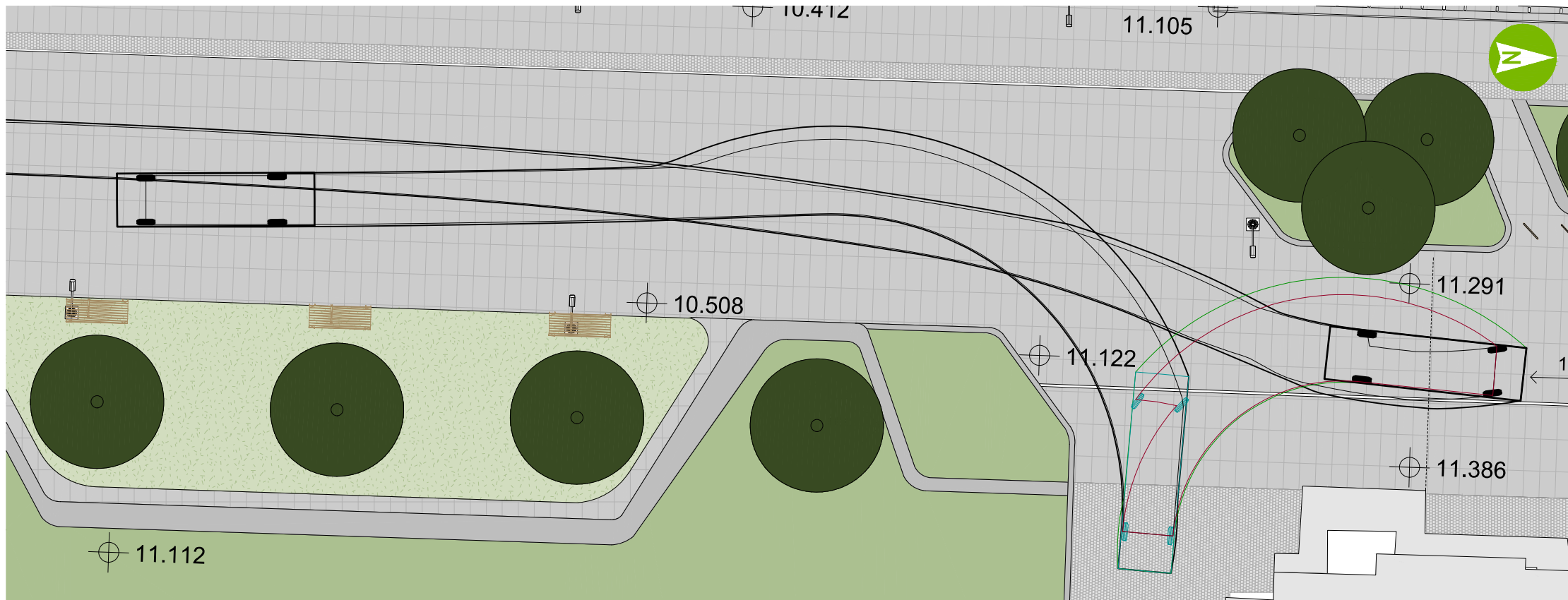

Stretched Limousine (70)	
Overall Length	24.283ft
Overall Width	6.542ft
Overall Body Height	5.025ft
Min Body Ground Clearance	1.039ft
Max Track Width	6.230ft
Lock-to-lock time	4.00s
Max Steering Angle (Virtual)	34.60°

1. VEHICLE TRACKING APPLICATION: AUTODESK VEHICLE TRACKING
2. TRACKING FOR FIRE AND EMERGENCY NEW ZEALAND (FENZ) AS PER GUIDANCE PROVIDED IN FENZ - F5-02 GD, FIREFIGHTING OPERATIONS EMERGENCY VEHICLE ACCESS GUIDE

**7.4m STRETCHED LIMOUSINE**  
1:100



File Date: 28/02/2021 11:28:25 AM    Client: Auckland    Filename: C:\USERS\STUART.HAMILTON\AURECON\PROJECT FILES\AURECON\CLIENTS\AURECON\255585 - PARLIAMENT FUTURE ACCOMMODATION STRATEGY\PARLIAMENT FUTURE ACCOMMODATION STRATEGY\SKT-RR-0007.DWG



REV	DATE	REVISION DETAILS	APPROVED
A		CONCEPT DESIGN	M. WELBY

SCALE	SIZE
1:100	A1
<b>DRAWN</b>	
S.HUNSEMAKKI	
<b>DESIGNED</b>	
S.HUNSEMAKKI	
<b>CHECKED</b>	
S.HAMILTON	

INFORMATION
NOT FOR CONSTRUCTION
<b>APPROVED</b>
DATE

PROJECT	PARLIAMENT FUTURE ACCOMMODATION STRATEGY (FAS)
TITLE	VEHICLE TRACKING MUSEUM STREET
DRAWING No.	255585 - 0600 - SKT - RR - 0007 - A

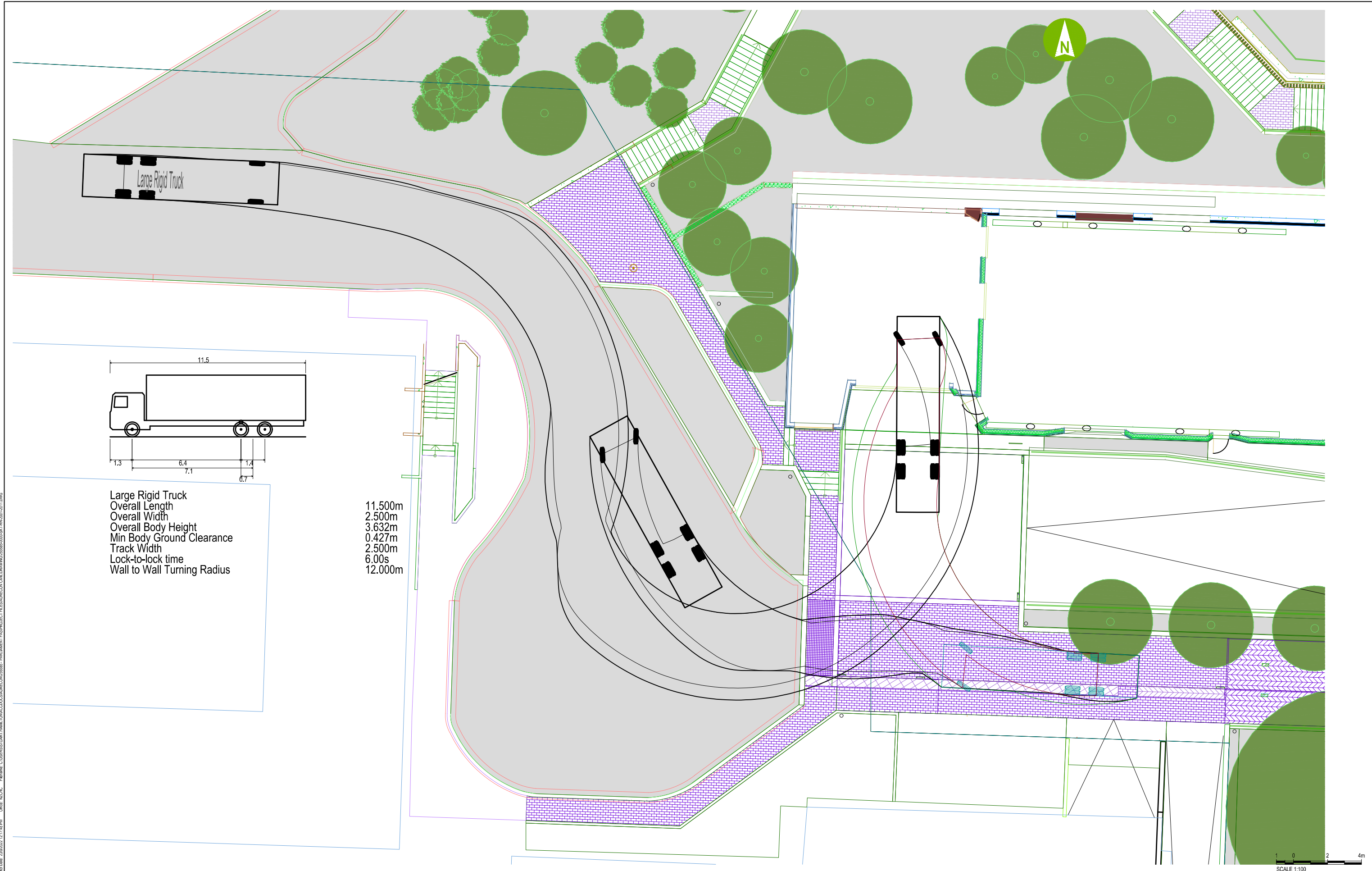

Large Rigid Truck  
 Overall Length 11.500m  
 Overall Width 2.500m  
 Overall Body Height 3.632m  
 Min Body Ground Clearance 0.427m  
 Track Width 2.500m  
 Lock-to-lock time 6.00s  
 Wall to Wall Turning Radius 12.000m

Plot Date: 23/02/2021 12:17:45 PM    Office: NDC/CC    File Name: C:\USERS\STUART.HAMILTON\WORKSPACE\AURECON\255585 - PARLIAMENT FAS\PROJECT FILES\AURECON\DRAWINGS\255585-SKT-RR-001-2011.DWG



REV	DATE	REVISION DETAILS	APPROVED
A		FOR INFORMATION	

SCALE	SIZE
1:100	A1

INFORMATION	APPROVED	DATE
NOT FOR CONSTRUCTION		

PROJECT	TITLE
PARLIAMENT FUTURE ACCOMMODATION STRATEGY (FAS)	VEHICLE TRACKING BAL PLACE - LARGE RIGID TRUCK

DRAWING No.	PROJECT No.	AREA	TYPE	DISC	NUMBER	REV
255585	0600	SKT	RR	0001	2009	



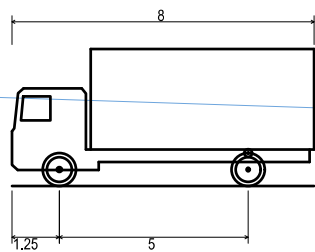
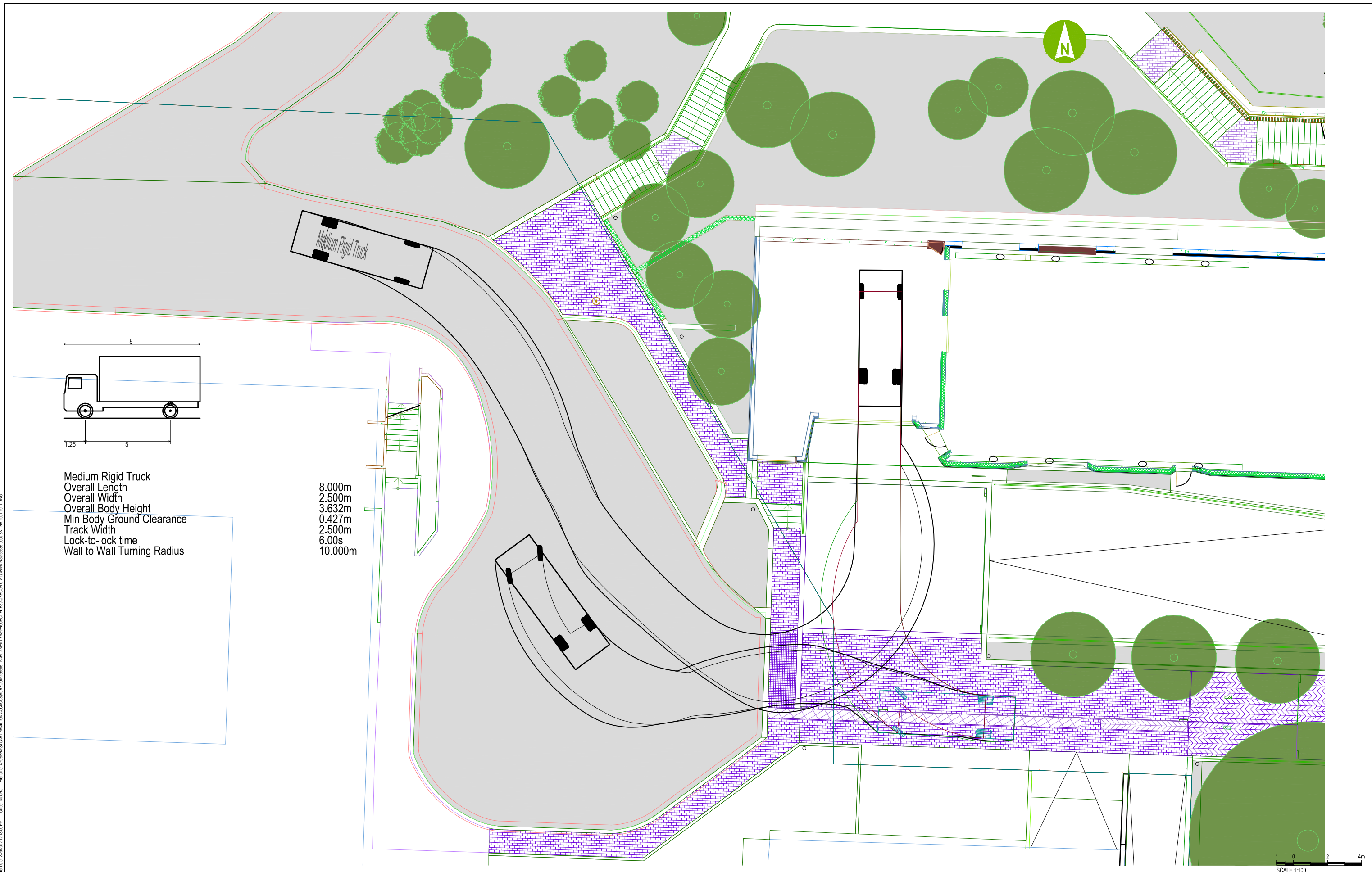

Medium Rigid Truck  
 Overall Length  
 Overall Width  
 Overall Body Height  
 Min Body Ground Clearance  
 Track Width  
 Lock-to-lock time  
 Wall to Wall Turning Radius

8.000m  
 2.500m  
 3.632m  
 0.427m  
 2.500m  
 6.00s  
 10.000m

File Path: C:\Users\stuart.hamilton\Documents\Aurecon\Projects\Parliament Future Project\Drawings\255585\SKT-RR-2010-2011.DWG  
 Date: 23/02/2021 12:18:07 PM  
 User: NDC



REV	DATE	REVISION DETAILS	APPROVED
A		FOR INFORMATION	

SCALE	SIZE
1:100	A1

INFORMATION	APPROVED	DATE
NOT FOR CONSTRUCTION		

PROJECT	TITLE
PARLIAMENT FUTURE ACCOMMODATION STRATEGY (FAS)	VEHICLE TRACKING BAL PLACE - MEDIUM RIGID TRUCK

DRAWING No.	PROJECT No.	AREA	TYPE	DISC	NUMBER	REV
255585	0600	SKT	RR	0001	-2010	

File Name: C:\USERS\STUART.HAMILTON\AURECON\PROJECT FILES\AURECON\CIVIL\DRAWING\255585-0000\SKT-RR-2011-011.DWG  
 Office: NZDC  
 Date: 23/02/2021 12:42:41 PM

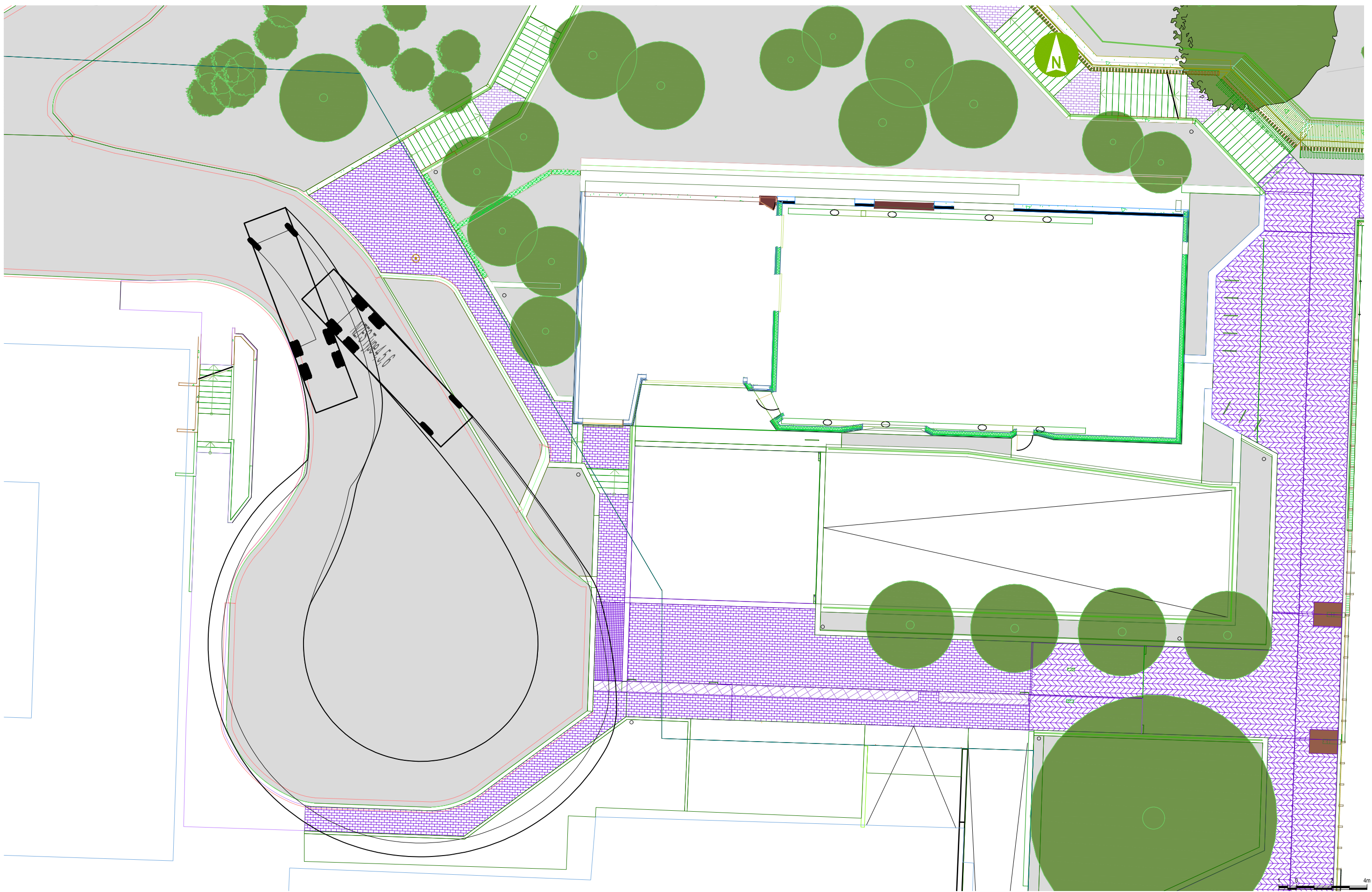

REV	DATE	REVISION DETAILS	APPROVED
A		FOR INFORMATION	

SCALE	SIZE
1:100	A1

INFORMATION	DATE
NOT FOR CONSTRUCTION	

PROJECT
PARLIAMENT FUTURE ACCOMMODATION STRATEGY (FAS)

TITLE
VEHICLE TRACKING BAL PLACE - NZFS TYPE 4, 5, 6

DRAWING No.	PROJECT No.	AREA	TYPE	DISC	NUMBER	REV
	255585	0600	SKT	RR	0001	-2011



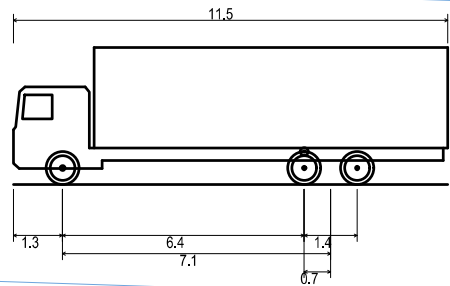

Large Rigid Truck  
 Overall Length 11.500m  
 Overall Width 2.500m  
 Overall Body Height 3.632m  
 Min Body Ground Clearance 0.427m  
 Track Width 2.500m  
 Lock-to-lock time 6.00s  
 Wall to Wall Turning Radius 12.000m

11.500m  
 2.500m  
 3.632m  
 0.427m  
 2.500m  
 6.00s  
 12.000m

Plot Date: 23/03/2021 12:38:43 PM    Office: NDC/CC    File Name: C:\USERS\STUART\_HAMILTON\WORKSPACE\AURECON\PROJECTS\PARLIAMENT\_FUTURE\PROJECT FILES\AURECON\CONTRIBUTING\DRAWINGS\255585\SKT-RR-2003-2111.DWG



REV	DATE	REVISION DETAILS	APPROVED
A		FOR INFORMATION	

SCALE	SIZE
1:100	A1

INFORMATION	APPROVED
NOT FOR CONSTRUCTION	DATE

PROJECT	TITLE
PARLIAMENT FUTURE ACCOMMODATION STRATEGY (FAS)	VEHICLE TRACKING BAL PLACE - LARGE RIGID TRUCK

DRAWING No.	PROJECT No.	AREA	TYPE	DISC	NUMBER	REV
255585	0600	SKT	RR	0001	2003	

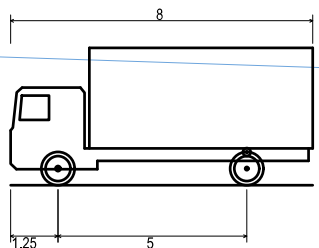
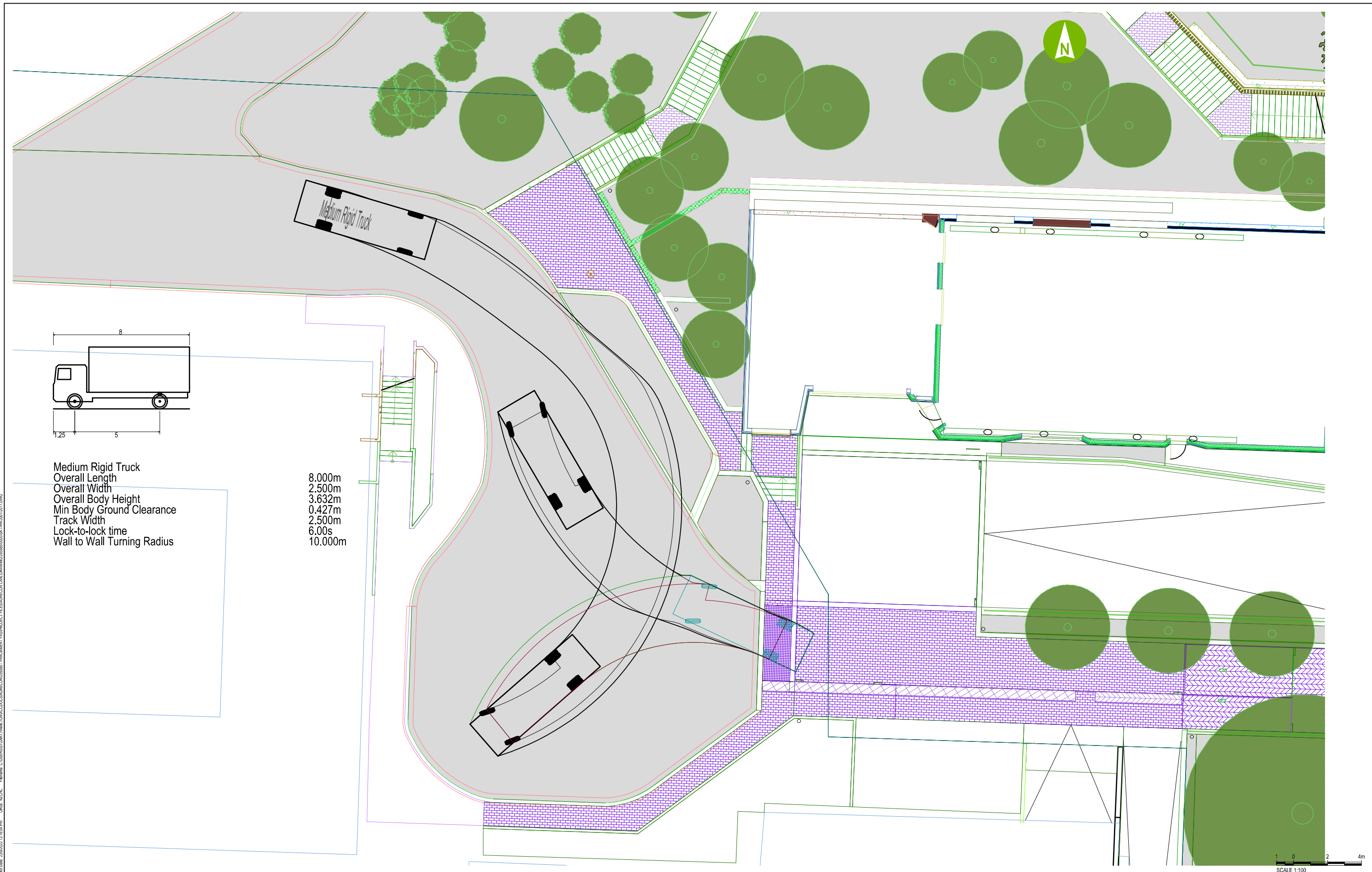

Medium Rigid Truck  
 Overall Length 8.000m  
 Overall Width 2.500m  
 Overall Body Height 3.632m  
 Min Body Ground Clearance 0.427m  
 Track Width 2.500m  
 Lock-to-lock time 6.00s  
 Wall to Wall Turning Radius 10.000m

P:\01\2020\2021\12-18-24\PM - Office - NDC\ - P:\Users\stuart.hamilton\Documents\Aurecon\255585 - Parliament Future Project\1\ES\Aurecon\Civil\Drawings\255585\SKT-RR-2001-2111.DWG

SCALE 1:100



REV	DATE	REVISION DETAILS	APPROVED
A		FOR INFORMATION	

SCALE	SIZE
1:100	A1

DRAWN	DESIGNED	REVIEWED
S.HUNSEMAKKI	S.HUNSEMAKKI	S.SONAKJEE

INFORMATION	APPROVED	DATE
NOT FOR CONSTRUCTION		

PROJECT	TITLE	PROJECT No.	AREA	TYPE	DISC	NUMBER	REV
PARLIAMENT FUTURE ACCOMMODATION STRATEGY (FAS)	VEHICLE TRACKING BAL PLACE - MEDIUM RIGID TRUCK	255585	0600	SKT	RR	0001	2004



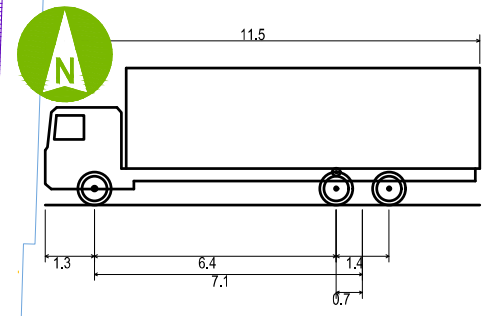
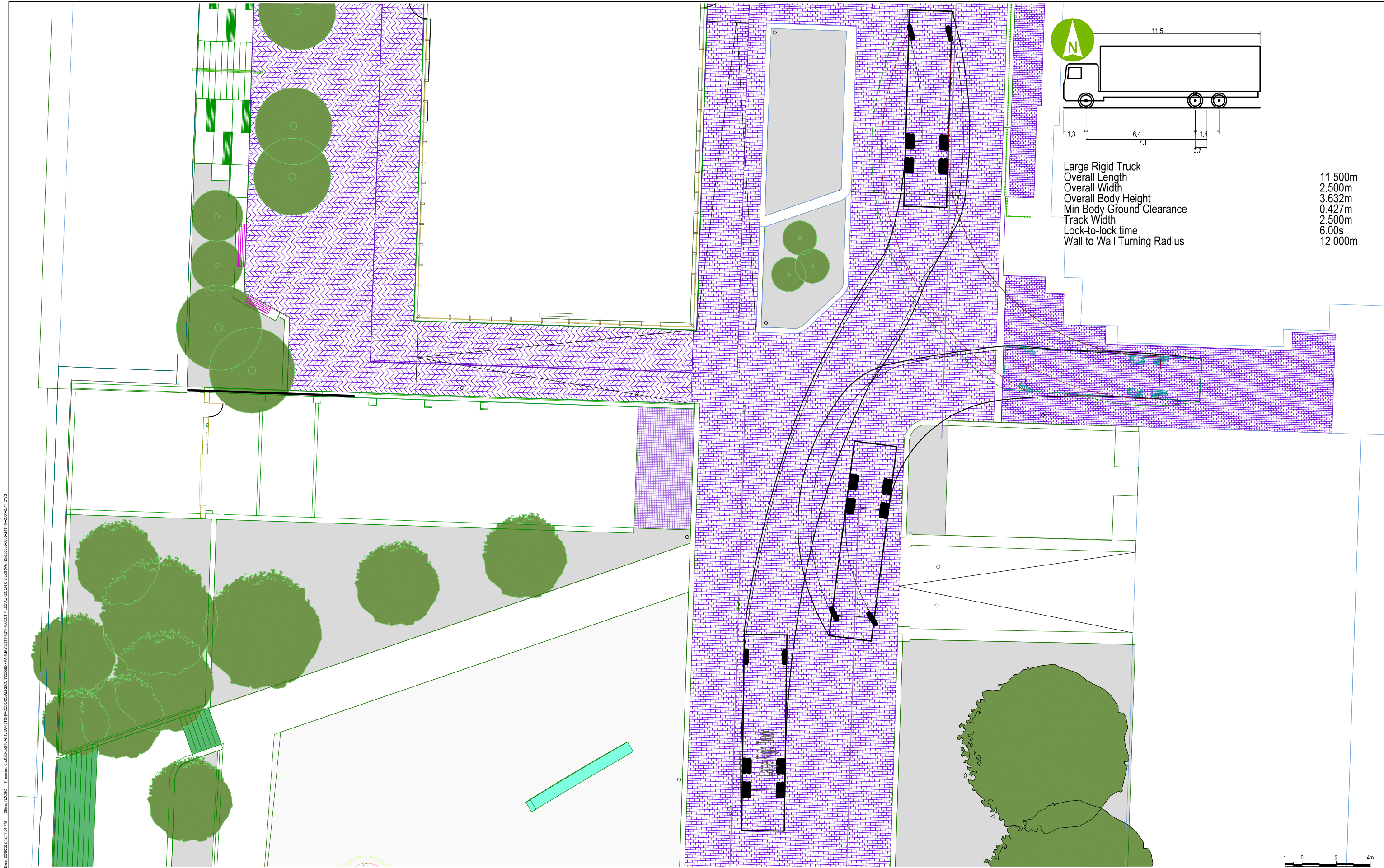

Large Rigid Truck  
 Overall Length 11.500m  
 Overall Width 2.500m  
 Overall Body Height 3.632m  
 Min Body Ground Clearance 0.427m  
 Track Width 2.500m  
 Lock-to-lock time 6.00s  
 Wall to Wall Turning Radius 12.000m



Plot Date: 23/02/2021 12:17:04 PM    Office: NDC    Path: C:\Users\stuart.hamilton\Documents\Aurecon\25585 - Parliament Future Project\TLEB\Aurecon\Civil\Drawings\25585\005\SKT-RR-2001-2011.DWG



REV	DATE	REVISION DETAILS	APPROVED
A		FOR INFORMATION	

SCALE	SIZE
1:100	A1

DRAWN	DESIGNED	REVIEWED
S.HUNSEMAKKI	S.HUNSEMAKKI	S.SONAKJEE

INFORMATION	APPROVED
NOT FOR CONSTRUCTION	DATE

CLIENT	PROJECT	TITLE
	PARLIAMENT FUTURE ACCOMMODATION STRATEGY (FAS)	VEHICLE TRACKING MUSEUM STREET - LARGE RIGID TRUCK

DRAWING No.	PROJECT No.	AREA	TYPE	DISC	NUMBER	REV
255585	0600	SKT	RR	0001	-2005	

**Document prepared by**

**Aurecon New Zealand Limited**

Level 4, 139 Carlton Gore Road  
Newmarket Auckland 1023  
PO Box 9762  
Newmarket Auckland 1149  
New Zealand

**T** +64 9 520 6019

**F** +64 9 524 7815

**E** [auckland@aurecongroup.com](mailto:auckland@aurecongroup.com)

**W** [aurecongroup.com](http://aurecongroup.com)

**aurecon**

*Bringing ideas  
to life*