

# FOOTPATH MANAGEMENT POLICY

21 MARCH 2007

## 1. Introduction

The primary use for footpaths is for pedestrian movement. Footpaths are also used for a variety of other activities such as outdoor café seating and street performances. These activities contribute to the character and vibrancy of our public spaces, but they can sometimes interfere with safe and efficient pedestrian movement. The Footpath Management Policy provides guidelines for activities which may be licensed on Wellington's footpaths and reinforces the pedestrian-priority principle.

## 2. Purpose

The Footpath Management Policy provides a balanced framework to ensure safe and efficient pedestrian movement on footpaths (pedestrian priority) while also providing opportunity for non-pedestrian activities. The Policy guides:

- the prioritisation of footpath space for pedestrian activity
- conditions for the licensing of non-pedestrian activities on footpaths
- the use of temporary footpath obstructions such as sandwich boards and seating.

## 3. Principles

The following principles shall apply when considering activities on footpaths:

- The Council's decisions on licensing activities on footpaths should be reflective of its strategic vision for the city.
- Pedestrian priority should be enhanced to facilitate more efficient and safe walking routes in Wellington and to encourage more people to walk as their primary transport mode where possible.
- Wellington streetscapes should be vibrant, safe and attractive, and when setting any rebate Council will consider how a proposed activity might positively contribute to achieving this principle.
- Wellington streetscapes should provide opportunities for pedestrians to participate in the public environment through leisure, retail, recreation and entertainment activities.
- Businesses, groups and individuals should be encouraged to use Wellington footpaths for non-pedestrian activities in a fair and balanced way that does not impair safe and efficient pedestrian movement. They are responsible for managing these activities in accordance with:
  - the relevant Council guidelines and the District Plan
  - New Zealand Standard 4121:2001 *Design of Access and Mobility – Buildings and Associated Facilities* (NZS4121), for accessible journeys and design elements
  - relevant legislation and standards, including for health and safety, and advertising.

- Council will consider how a proposed activity might negatively impact on the amenity of the proposed area, with special regards to noise levels. The proposed activity must comply with any relevant rules of the District Plan, and, if required, a land use consent must be obtained. A land use consent is likely to be required for any commercial activity in a residential area.
- Private initiatives that introduce changes to paving or permanent street features (e.g. barriers) for amenity purposes will generally not be approved.
- Wellington should have a balanced parking provision that takes into account the Council's long-term strategic goals for transport in the city.
- Fees shall be reviewed annually and generally set on a full cost-recovery basis.

#### **4. Scope**

The Footpath Management Policy guidelines provide conditions for approval for the following licensed activities involving temporary obstructions on public footpaths:

- retail stands
- sandwich boards, and other temporary obstructions such as welcome mats and menu boards
- outdoor seating and street furniture
- street appeals and charity fundraising stalls
- street performances and busking.

Temporary retail and food stalls, retail kiosks, recreational equipment hire, hawking and open air markets are not provided for under the Footpath Management Policy. For information about these trading activities, applicants should refer to the Trading in Public Places Policy, November 2006.

#### **5. Fees and charges**

Fees will be set in alignment with the Council's revenue and financing policy which requires that the costs of this policy, including enforcement, will be fully recovered from licence fees. Licence fees are expected to include the costs of:

- licensing
- monitoring and enforcement
- administration.

The Council reserves the right to provide a rebate against fees in special circumstances in recognition of particular contribution to streetscape vibrancy made through investment by a business in a public space. Such investment would always be undertaken in strict co-ordination with the Council.

The Council reserves the right to set at zero, the fees for some licensed activities, including:

- street performance and busking
- street appeals and charity fundraising.

The licence applicant must pay in full any licence fee and have all the required approvals before the licence will be issued.

## **6. Applying for a footpath licence**

### **6.1 Engaging in a licensed activity**

A licence is required before engaging in the activities covered by this policy. Businesses that do not have a valid footpath licence are not permitted to engage in these activities on footpaths or other walkways. Businesses, groups or individuals wishing to engage in a licensed activity on public footpaths or other pedestrian areas, should become familiar with the relevant guidelines and conditions herein, and apply to the Council for a footpath licence.

### **6.2 Approval process**

The Council will consider applications against the relevant conditions and criteria. The Council will notify the applicant in writing of the outcome of the approval process. The Council may require modifications with the applicant's proposal and these will be discussed with the applicant before approval is granted.

The Council will generally notify applicants of the outcome of the approval process within 15 working days. On occasion, some outdoor seating applications may require more time than this. Where delays are likely, applicants will be informed.

### **6.3 Application requirements**

All businesses, organisations, groups or individuals wanting to engage in a licensed activity covered by this policy must first complete an application form and receive Council approval.

Applicants must provide the following when submitting an application for a licence:

#### **6.3.1 for all footpath licences**

- a fully completed application form
- the appropriate fees (if any) in accordance with the Council's Schedule of Fees and Charges.

#### **6.3.2 for sandwich boards**

- the above, and
- a scaled site plan of existing conditions that accurately shows:
  - the width of the footpath from the building facade to the kerb edge
  - the proposed location of the temporary obstruction in relation to existing features, including neighbouring properties, street trees, rubbish bins, street light poles, signs, pillars, street furniture, fire hydrants, parking meters, telephone boxes, mail boxes or any other significant features on the footpath
  - a measurement of the continuous width of the unobstructed pedestrian thoroughfare in relation to temporary obstruction (sandwich board, retail display or outdoor seating area)
  - the location of all doorways and service openings
- the exact location of any veranda covering at the site in relation to the proposed activity area and kerb edge.

### **6.3.3 for retail displays**

- all of the above, and
- a scaled site plan of existing conditions that accurately shows:
  - the proposed layout of all items for the activity area in relation to existing features, including neighbouring properties, street trees, rubbish bins, street light poles, signs, pillars, street furniture, fire hydrants, parking meters, telephone boxes, mail boxes or any other significant features on the footpath
  - an indication of the total area, in square metres, to be used for the proposed activity, including any temporary obstructions and access requirements
- colour photographs of the proposed activity site, including any existing footpath features
- colour photographs or architectural drawings of all items in any proposed display, seating or other temporary obstruction.

### **6.3.4 for outdoor seating areas**

- all of the above, and
- measurements of the height clearance of any umbrellas to the footpath
- evidence of public liability insurance, to the satisfaction of the Council, for a minimum of \$1,000,000 that covers the proposed outdoor seating area
- disclose whether alcohol is to be supplied/served/consumed in the proposed outdoor seating area. (Note: a separate application for a redefinition of the licensed area will be required if liquor is to be served / consumed in the outdoor area. This is required under the terms of the Sale of Liquor Act 1989.)
- identification of the type of any proposed heating devices, and the required safety features.

### **6.3.5 for outdoor area special licences**

- all of the above, and
- the proposed location and size of any tents or marquees
- safety barriers, signage or barriers to delineate pedestrian areas
- any request to use car park space or other road space. A separate application may be required for this
- the proposed pedestrian thoroughfare and a traffic management plan.

### **6.3.6 for street appeals or charity fundraiser stalls**

Applications for a licence for a street appeal or a charity stall in a public space must include:

- evidence of the organisation's legal structure and non-profit status (for the first application only)
- the proposed date of the street appeal or fundraiser stall, and that for any relevant national appeal of their organisation
- an estimate of the number of collectors and a summary of proposed collection location(s)
- a copy of any licence required from the Department of Internal Affairs for organisations that employ a promotional company to run a lottery as part of a street appeal.

## **7. Monitoring and enforcement**

### **7.1 Monitoring**

Businesses, individuals and groups are responsible for managing activities on the footpaths in accordance with the relevant policy guidelines for their activity.

The Council will monitor non-pedestrian footpath activities regularly to ensure that the activities are being operated in compliance with the licence conditions, including those for street performance and busking, and that no unauthorised activity is occurring in public places.

### **7.2 Non-compliance with licence conditions**

The Council reserves the right to revoke a footpath licence or lease for non-compliance issues. The standard protocol for non-compliance is as follows for businesses, individuals or groups that have permission to conduct activities outlined in this policy:

1. If a licence holder does not comply with the conditions of this policy, the Council will, on the first occasion:
  - provide information to ensure all parties know what is required
  - verbally notify the business, individual or group of the issue and provide a warning of the consequences of future infringement.
2. For a second infringement, the Council will provide a written second warning to the business, individual or group identifying the issue(s), required remedy and timeframe, and consequences of future infringement.
3. For a third infringement, the Council will take appropriate action, selecting from such options as revocation of the footpath licence and confiscation of items located on public space.

Safety considerations remain paramount, and officers retain the option of requiring immediate action in the event of an operator creating a risk to safety.

### **7.3 Non-licensed activities**

Businesses, individuals or groups that conduct private, non-pedestrian activities on footpaths or other public spaces without a footpath licence will be asked to stop and be requested to remove any items located on the footpath. They will receive a written warning from the Council and be invited to apply for a licence.

### **7.4 Confiscations**

If the party continues to infringe without a footpath licence, the Council reserves the right to confiscate any items placed on public places pursuant to sections 163 and 164 of the Local Government Act, 2002, and under the part 1.15.1 of the Wellington Consolidated Bylaw: any authorised servant of the Council may pull down, remove or alter any work, material or thing erected or being in contravention of any provision of this bylaw.

The Council may dispose of confiscated property pursuant to section 168 of the Local Government Act, 2002.

## **8. General conditions**

This section contains conditions which apply to all footpath licence applications. The following sections set out additional conditions for particular types of activity.

### **8.1 Pedestrian priority**

The primary purpose and priority use for footpaths is safe and efficient pedestrian movement, including ‘eddies’ where pedestrians can stop or stay, for a chat or a rest. Activities and obstructions that interfere with pedestrian flows can create pedestrian congestion and safety hazards. The Council requires that minimum continuous unobstructed footpath widths are maintained to ensure that pedestrian priority and safe and efficient pedestrian movement is upheld. The minimum widths are guided by the volume of pedestrian traffic.

There are three tiers of minimum footpath width:

- 4 metres for Lambton Quay and Willis Street
- 3 metres for Manners Street, Manners Mall, Cuba Street, Cuba Mall and Courtenay Place
- 2 metres for all other locations in the wider city, that is, Wellington District.

On occasion the available footpath space is such that the designated width is unachievable because of the large variation in footpath width that exists throughout Wellington. The Council may make minor discretionary modifications to the ideal minimum unobstructed footpath widths as appropriate.

The Council will grant licences against the guidelines herein for non-pedestrian activities that will bring life and atmosphere to locations in the city. Factors that could be considered when determining locations for non-pedestrian footpath activities include:

- preservation of the designated continuous, uninterrupted footpath widths, and safe and efficient pedestrian movement
- pedestrian priority. Other than for retail displays, pedestrians will generally have priority along building frontages and under veranda spaces, with design elements, such as seating, sited on the kerb-side if space allows
- maintenance of safe and efficient pedestrian flows
- secondary functions of the location, such as bus queuing.

The Council reserves the right, at its sole discretion, to vary the unobstructed footpath widths set for a particular area.

### **8.2 Licence period**

Licences for retail stands, sandwich boards and outdoor seating are valid for one year, unless stated otherwise on the licence.

Street appeals and charity fundraising stalls are valid for the approved appeal week.

Street Performance Licences are valid for 6 months.

### **8.3 Compliance with the District Plan**

The proposed activity must comply with any relevant rules of the District Plan, and, if required, the applicant must also apply for a Land Use Consent to undertake a commercial activity in a residential area. Council will consider how the proposed activity might adversely impact on the amenity of the area, with special regards to noise levels. As a guide only, noise from any street performance should not be greater than reasonable background noise when heard from more than 30

metres, horizontally or vertically, from where the performance is taking place. For detailed requirements, for loud speakers for instance, applicants should refer to the District Plan standards.

#### **8.4 Marking of areas**

It is the licensee's responsibility to reasonably ensure that any items placed on the footpath remain in their designated locations, including if shifted by wind or patrons.

Areas for approved temporary obstructions, such as seating or retail displays, may be required to be marked, as stipulated by the Council. This will help to ensure that furniture remains in the approved area, and assist licence holders and Council officers with monitoring.

The Council will be responsible for determining the level of delineation required, and will also manage the design, installation and removal of all markers. The markers must remain in place throughout the duration of the footpath licence. All furniture, including umbrellas and plants, must be kept strictly within the boundaries of the approved seating area. The cost of installing, maintaining and removing outdoor seating markers will be met by the licensee.

To assist in the detection of approved areas and of temporary obstructions by people with visual impairments, tactile markers or solid barriers may be required as part of the design.

#### **8.5 Storage**

All temporary obstructions, including sandwich boards, seating, heaters, umbrellas and planters, must be removed from the footpath outside of the businesses trading hours and stored away from the public area.

#### **8.6 Evidence of holding a licence**

For retail displays and outdoor seating, the footpath licence and approved site plan must be displayed in the licensed area, or in the business's window, so that it is visible at all times.

For sandwich boards the licence sticker must be displayed on the board at all times, and the licence produced on request by an authorised person.

Street appeal collectors, and charity stalls, must be clearly identifiable and display the name of their organisation and the appeal. This is often done with a badge, tag or a pull-over bib. For collections, the organisation must have a licence and, in their application, provide a contact person who is readily available throughout the collection period. Stall holders must carry their licence and have it ready to show on request.

At all times whilst performing, street performers and buskers must have their Street Performance Licence, and Special Street Performance Permit for each performer where appropriate, on display or ready to show if asked by any Council officer or member of the public.

#### **8.7 Variation of conditions**

The Council reserves the right, at its sole discretion, to decline an application for over-riding factors relating to the principles of this policy, including pedestrian safety, density and flow requirements. Where an application may otherwise meet the necessary conditions but is still to be declined, officers will endeavour to work with applicants to explore suitable alternatives, if available.

The applicant must comply with the conditions of the footpath licence as detailed in these guidelines. The Council may revoke the footpath licence at any time if the conditions of the approval are not being sufficiently met.

The Council also reserves the right to vary the footpath licence at any time if it is in the public interest to do so, including in response to factors such as changes in pedestrian patterns. Reasonable notice will be provided to the licensee in such a situation.

## **9. Guidelines for retail displays**

### **9.1 Introduction**

Retail displays are used by businesses to help increase sales and attract customers into shops. They are deemed to be an extension of the retail display inside the shop.

High quality retail displays can enhance the variety and vitality of building frontages, depending on their appearance and location. The quality of the appearance of building frontages facing the footpath is an extremely important factor for the quality of an urban area.

If retail displays are not properly managed they can create obstacles for pedestrians and impede pedestrian flows. Licensed display areas must consider the space required for the display stand and the space required for access to the stand.

### **9.2 Purpose and scope**

These guidelines outline the conditions for approval of retail displays. They apply to all businesses that want to put retail displays on the footpath. They should be read in conjunction with the rest of the Footpath Management Policy Guidelines.

### **9.3 Licences**

- A retail display footpath licence does not permit trading from the approved retail display on the footpath. Applications for a Temporary Retail Stall Licence can be made to the Council.
- Businesses without a retail display footpath licence will not be permitted to display goods on the footpath.
- Retail displays will only be licensed on footpaths or other pedestrian spaces and are not permitted on the road including parking spaces, loading zones, bus stops and taxi stands. Additional restrictions may be applied adjacent to bus stops, taxi stands or disability parking spaces.
- No goods for sale may be left directly on the footpath. All goods must be completely contained within the display cabinet, rack or frame, such that they can be easily removed from the footpath if required, without causing any damage to the footpath.
- Retail display licences do not supersede other regulations or policy, such as the Parking and Footpath Policy, and requirements for health and hygiene.

### **9.4 Size, location and design of retail stands**

- Retail displays shall be placed on the footpath in the designated location immediately in front of the retail outlet.
- All display goods must be elevated from the ground, on a plinth, podium, frame, table or rack, for example.
- Retail displays shall be of high quality, tidy, stable and wholly contained within the display area, to the satisfaction of the Council.
- Retail displays must comply with NZS4121: 2001, including in respect to:
  - stability and safety
  - having no sharp edges or protrusions that may create an obstacle or a safety hazard for pedestrians
  - having a solid feature within 150mm of the ground

- access to goods. For access from a wheelchair, the maximum distance from any display edge must be not more than 500mm.
- If the display must be accessed from the footpath side, at least 500mm must be allowed for this, outside the designated unobstructed footpath width.
- Retail display stand may extend up to 800mm from the building facade, where the combined required unobstructed footpath width and customer access room still allows sufficient space for this.
- In line with fire regulations, neither the retail display nor requirements for access to the displayed items, such as from a wheelchair, may obstruct access to or egress from the premises, or access to panels for fire alarms, fire hydrants or sprinkler systems.

### Guideline for acceptable retail display set-up

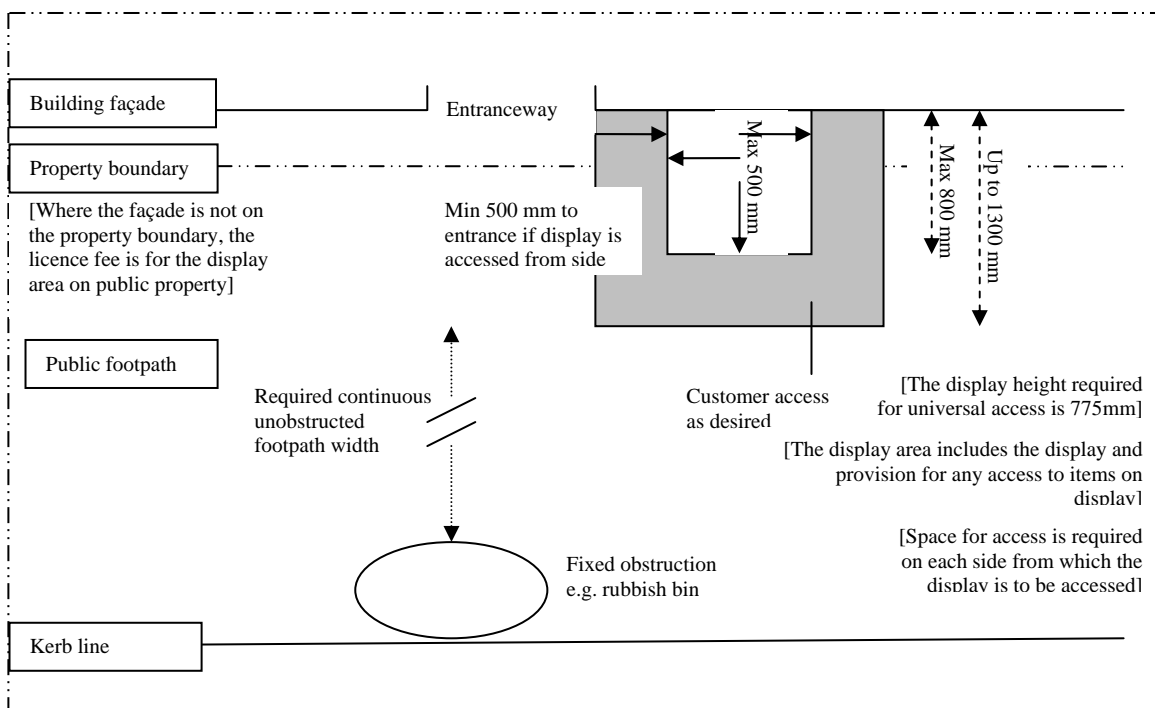

## 9.5 Business responsibilities

- Wellington City Council accepts no responsibility for the security of items on display.
- Retail displays containing food must comply with all aspects of the Food Hygiene Regulations (1974), or any subsequent legislation resulting from the New Zealand Domestic Food Review that may replace these regulations.
- Retail displays must comply with relevant Advertising Standards Authority requirements.
- Businesses are responsible for cleaning the retail display area and its immediate surroundings, including by regular sweeping.
- Retail displays must be removed from the footpath outside of the businesses trading hours.

## **10. Licence conditions specific to sandwich boards**

### **10.1 Introduction**

Sandwich boards may be licensed on public footpaths in locations in the city where the pedestrian priority principle has been applied and sufficient footpath width remains available. Sandwich boards are used by businesses to help increase sales and attract customers into shops, but if they are not properly managed they can create obstacles for pedestrians and impede pedestrian flows. Depending on their appearance and location, sandwich boards can affect the quality, vitality and variety of building frontages.

### **10.2 Purpose**

These guidelines outline the conditions for approval of sandwich boards. They should be read in conjunction with the rest of the Footpath Management Policy Guidelines.

### **10.3 Scope**

These guidelines apply to all businesses that want to put a sandwich board on the footpath or other pedestrian area. Flat magazine advertisements and other displays that sit flush against the building facade do not require a licence.

Potted plants, welcome mats, and menu display boards of non-flat design for use out of an approved seating area will be considered as for sandwich boards and must be licensed by the council. The Council may require marking of the approved locations for such items.

The Council may work with collections of businesses that lack visibility from the street, above or below ground level or on side streets, for instance, to find suitable alternatives for on-street signage, or consider requests for alternative locations and types of signage, where it considers, at its sole discretion, that this will contribute to the achievement of the Council's goals. This may include the installation of a single, permanent, collective display sign that lists the names of businesses located in off-street locations.

### **10.4 Location of sandwich boards**

- Sandwich boards displayed on the footpath shall be limited to one per retail premise.
- All sandwich boards shall be placed at the kerb edge of the footpath adjacent to the relevant premises, unless otherwise approved by the Council. Sandwich boards should be positioned in line with other obstructions, such as other sandwich boards. Generally, to reduce any risk of impact for visually impaired pedestrians, the flat face of the board should be parallel to the road. In line with fire regulations, the sandwich board must not obstruct access to or egress from the premises.
- No sandwich boards shall be approved adjacent to bus stops, disability parks, taxi stands or pedestrian crossing locations. Sandwich boards may not be attached to fixed or temporary street furniture without prior written approval from the Council.
- The licence holder is responsible for ensuring the sandwich board remains located in the designated position, including if moved by pedestrians or wind. Sandwich boards must be removed from the footpath outside of the businesses trading hours.

## 10.5 Design and maintenance

- Sandwich boards must comply with relevant Advertising Standards Authority requirements.
- The approved sandwich board design has a wide base which can be identified easily by people who are blind or who have visual impairments. To improve visibility, the base or a strip on the base must be of a colour in contrast to the footpath.
- Sandwich boards should be safe and have no sharp edges or protrusions that may create an obstacle or a safety hazard for pedestrians. Rotating designs shall not be approved anywhere in the District.
- All sandwich boards shall have dimensions in accordance with the Council's regulations (maximum of 600mm wide by 600mm deep by 900mm high).
- Sandwich boards shall be weighted to ensure stability and must be taken inside when there is a risk that wind gusts may topple them or change their position. Bases designed to be weighted by water must be kept in operating order. To prevent them collapsing in windy conditions, easel-type boards must have a mechanism that locks them in their open position.
- They shall be kept in a clean and tidy condition.

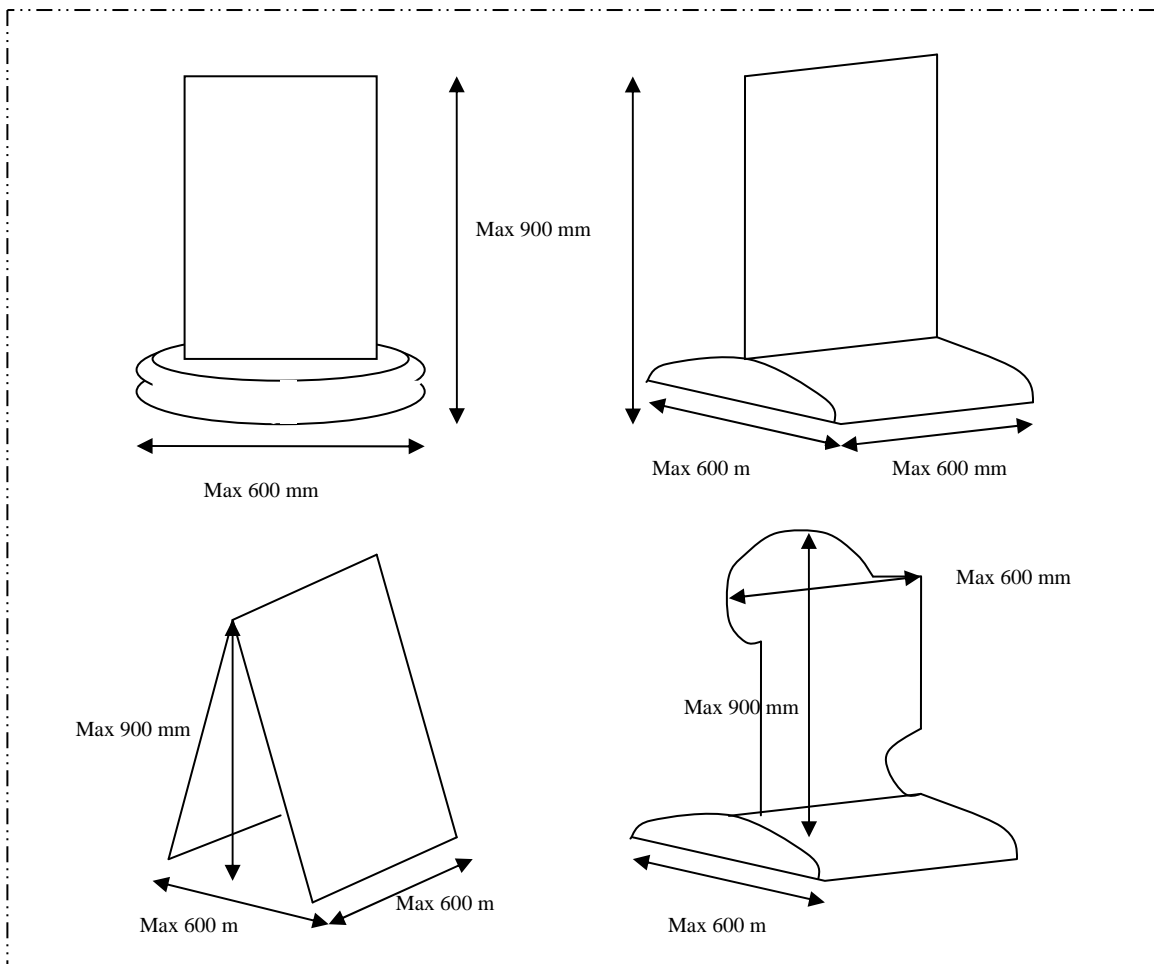

## **11. Guidelines for outdoor seating**

### **11.1 Introduction**

High quality temporary outdoor seating can add to the vibrancy of Wellington's city streets and other public spaces if well designed and located. Outdoor seating contributes to Wellington's sense of place and provides the public with an enjoyable leisure option. It can also add significant value to cafes, bars and restaurants through increased customer capacity and increased customer demand.

In general, the Council wants to encourage outdoor seating because it adds to the quality of public spaces. However, if outdoor seating is not managed well it can clutter the footpath and create obstacles for pedestrians.

### **11.2 Purpose and scope**

These guidelines outline the conditions for approval of outdoor seating areas on footpaths and other public spaces where food and/or beverages are served in the Wellington District. They form part of the Footpath Management Policy Guidelines, and must be read in conjunction with those guidelines.

### **11.3 Licensed areas for outdoor seating**

These areas may include streets, malls, parks and other public spaces. Some areas, such as areas with steep footpath slopes, street corners, pedestrian crossing entrance points, elevated areas without proper safety rails, or civic or cultural areas, may not be ideal for outdoor seating. Outdoor seating may be approved on footpaths and some other public spaces where:

- it will not interfere with safe and efficient pedestrian movement and the minimum unobstructed footpath widths can be maintained
- local conditions are favourable to their operation.

The Council may require marking of the approved locations for outdoor seating areas.

### **11.4 Layout for outdoor seating areas**

The licence holder is responsible for ensuring that patrons keep the outdoor seating within the approved boundaries of the outdoor seating area.

All outdoor seating should be located adjacent to the licence holder's premises, within the width of their building frontage. Outdoor seating may be under veranda cover where pedestrian priority has been provided for and sufficient room remains available. Alternatively, the Council may request a modification to the proposed outdoor seating area to achieve the right balance of unobstructed pedestrian walkway and outdoor seating covered by veranda space.

The layout and orientation of furniture in the proposed seating area must allow for:

- unobstructed access to and from the premises in accordance with fire evacuation requirements
- sufficient space for easy movement throughout the seating area and for chair use
- at least 0.8m to the adjacent kerb line to ensure safety of patrons.

Outdoor seating will not be permitted on street corners with pedestrian crossings or near entry points of designated pedestrian crossings. Requests from businesses for seating approvals on a floor level other than the one on which the premises are located, are unlikely to be approved because of the management responsibilities required.

Diagrams showing examples of how tables and chairs may be set up are available from the Council.

### **11.5 Design elements**

Each outdoor seating furniture element to be located within an approved area is deemed to constitute a temporary obstruction. This may include, but is not limited to, tables, chairs, menu boards, umbrellas, heaters, potted plants, and barriers or 'fences'.

Such design elements should be high quality, durable, waterproof and weather resistant, designed for outdoor use and well-maintained. Outdoor furniture should integrate well with the surrounding environment and must be safe and comfortable. The design of all elements must comply with NZS4121 and be approved by the Council.

All elements must be removed from the outdoor seating area, and stored away from public areas, outside the operating hours of the business or when not in use due to bad weather.

#### **11.5.1 Umbrellas**

Umbrellas must not penetrate or damage the surface of Council footpaths and must not interfere with pedestrian movement.

They must be securely fixed to withstand the effects of wind, and removed in high winds or when the outdoor seating is not in use.

#### **11.5.2 Menu display boards and potted plants**

Where menu display boards or potted plants are included in an approved seating area plan, they can be used only in the approved area. Sandwich boards used for advertising are not permitted in outdoor seating areas.

For menu boards outside of a seating area, those that sit flush against the building façade require no permit. Potted plants and menu display boards of non-flat design for use out of an approved seating area will be considered as for sandwich boards and must be licensed by the council. The Council may require marking of the approved locations for such items.

#### **11.5.3 Permanent structural barriers**

Outdoor seating areas should be open, accessible and inviting to the public. Therefore, permanent glass barriers, screen barriers, planter boxes or other permanent barriers are generally not permitted on Council footpaths or public spaces. However, the Council will consider the necessity of installing permanent barriers along the kerb line for safety reasons on a case-by-case basis. Such barriers must comply with Council design requirements and will be deemed to be part of the approved outdoor seating area. If the safety barrier is deemed necessary, the costs of installation and maintenance will be borne by the business. In addition, a bond fee may be required to cover the costs of barrier removal and footpath reinstatement at the termination of the licence.

#### **11.5.4 Temporary structural barriers**

All temporary barriers in outdoor seating areas must be approved by the Council. The Council may consider proposals for the use of temporary barriers to separate adjoining outdoor seating areas and pedestrian thoroughfares. This may include temporary planter boxes, temporary screens or ropes. Temporary screens must be located within the approved outdoor seating area and must be removed from the public area when the outdoor seating area is not in use. The Council will not approve temporary barriers that negatively affect the quality of public spaces either through aesthetic values or safety, to the satisfaction of the Council.

Temporary planter boxes must be well maintained by licence holders and the Council reserves the right to order the removal of planter boxes that are not properly maintained.

### **11.5.5 Heating devices**

The Council does not consider outdoor heating to be an efficient use of energy and does not encourage its use.

The type and proposed location of any heating devices must be included in footpath licence applications. Permanent heating devices that are fixed into the footpath will not be permitted.

Temporary heating devices must:

- turn off automatically if overturned
- be securely fixed and stable to withstand the effects of wind
- not penetrate or damage the surface of Council footpaths
- not interfere with pedestrian movement
- be removed when outdoor seating is not in use, and in extreme wind conditions
- have sufficient clearance from umbrellas and verandas
- be of a design approved by the Council and be well maintained.

### **11.6 Monitoring and maintaining outdoor seating areas**

Licence holders are required to continually monitor and maintain the outdoor seating area, to the Council's satisfaction. This includes:

- ensuring that outdoor furniture and patrons stay within the approved outdoor seating area
- maintaining outdoor furniture to a high aesthetic standard
- providing ashtrays for tables if smoking is allowed in the area
- cleaning the approved seating area throughout the opening hours including:
  - tables, chairs and immediate footpath surrounds
  - cigarette butts from ashtrays and footpath.
- meeting their responsibilities under the Sale of Liquor Act 1989 and the Council's Liquor Licensing Policy.

When cleaning, licence holders must dispose of rubbish in their own bins. Licence holders are not permitted to dispose of rubbish in Council litter bins or sweep cigarette butts and litter from outdoor seating onto the footpath, kerb channel or street.

### **11.7 Toilet facilities**

Applicants must have adequate toilet facilities to cover both indoor and outdoor seating numbers. Inclusion of outdoor seating increases the total number of seats on the premises and an increase in toilet facilities may subsequently be required. Alternatively, applicants can remove indoor seating in preference for outdoor seating if increasing toilet facilities is not a viable option.

### **11.8 Lighting**

All approved outdoor seating areas must provide adequate lighting, to the Council's satisfaction, to ensure the safety and amenity of patrons and the general public.

### **11.9 Footpath widening requests**

The Council occasionally receives requests to widen the footpath in areas where there is insufficient room to accommodate outdoor seating. Businesses that are interested in footpath extensions to accommodate outdoor seating need specific approval from the Council.

Any consideration of footpath widening projects will be informed by relevant strategy and policy developments including transport and urban design initiatives such as the Central City Development Plan, and the Parking Policy.

### **11.10 Special licences for footpath usage**

The Council allocates special licences for footpath usage, under the Footpath Management Policy, for major events such as sporting events, holidays and other special occasions (e.g. movie premiers). Licences may cover seating, tents and other related temporary obstructions. Any business or organisation that is interested in using the footpath for a special occasion must receive permission from the Council. Licences are not permanent and businesses and organisations must reapply for permission for each event. Businesses must provide detailed plans for each application for a special licence.

The Council requires that at least 1.2 metres of footpath space is maintained for pedestrian thoroughfare for these licences, but generally greater width is needed to provide for sufficient safe pedestrian flow. A traffic management plan may also be required to demonstrate how pedestrian and vehicle flow is to be managed. The Council may place additional conditions on a licence such as safety barriers, signage, or ramps for pedestrian passage across kerbing.

## **12. Guidelines for street appeals and charity fundraisers**

### **12.1 Introduction**

Street appeals and charity fundraisers are coordinated and organised events by organisations that ask for, or seek, any subscription, collection or donation from members of the public. Street appeals will usually involve more than one collection person and location operating at the same time.

The Council wants to support organisations with their annual street appeals, and with charity fundraisers, in a managed way to minimise conflict with other activities on public spaces such as pedestrian movement and retail activity. The conditions for conducting street appeals and charity fundraisers in Wellington City are set out below.

### **12.2 Purpose and scope**

These guidelines outline the conditions for approval of street appeals and charity fundraisers on footpaths and other public spaces in the Wellington District. They form part of the Footpath Management Policy Guidelines, and must be read in conjunction with those guidelines.

### **12.3 Conditions for street appeals**

The Council wants to provide the opportunity for all eligible organisations to conduct an annual street appeal. To be eligible to hold a street appeal in Wellington City, organisations must be a legally constituted, non-profit making society, association or organisation.

The Council will send out application forms to organisations on the Council's street appeal register in May each year so organisations can request specific dates. Once all applications are received, the street appeal dates will be confirmed by the end of August. The Council will set the annual appeal dates at its discretion, endeavouring to spread street appeals evenly across the year, and will try to accommodate the needs of all organisations. Special consideration may be given to organisations

that have designated national street appeal dates. Organisations should be aware that they may not be guaranteed their first choice of street appeal date as some dates are in high demand.

Organisations that are interested in being placed on the Council's street appeal register or that want to set up a street appeal outside of the standard application process should contact the Council.

As a courtesy to the Council, organisations that intend to cancel an annual street appeal should notify the Council at least two months prior to the date so that the date can be re-allocated if possible. Organisations that cancel more than two annual appeals consecutively may be deleted from the Council's street appeal register.

The following conditions apply to organisations conducting street appeals:

- Organisations will not be licensed for more than one appeal date per year.
- Street appeals must not obstruct safe and efficient pedestrian flows on footpaths and other pedestrian areas. The Council may set additional specific safety requirement conditions. If the street appeal impacts on traffic flows or parking spaces, other permissions may be required from the Council.
- Collectors must not block the entrances to businesses, residences or public buildings
- Collectors must be clearly identifiable and display the name of their organisation and the appeal. This is often done with a tag or a pull-over bib. The organisation is responsible for the promotion and identification of its collectors.
- Organisations wishing to employ a promoter to conduct a lottery on their behalf must apply for a licence from the Department of Internal Affairs to conduct this activity.
- All collection areas must be left clean and tidy.

#### **12.4 Conditions for charity fundraiser stalls**

Charity stalls selling raffles, handcrafts and confectionary items are approved by the Council on a case by case basis. The Council is generally supportive of charity fundraisers.

The following conditions apply to charity stall fundraisers:

- The stall must be for a registered non-profit organisation.
- Charity stalls must not obstruct safe and efficient pedestrian flows on footpaths and other pedestrian areas.
- Charity stalls must not block the entrances to businesses, residences or public buildings.
- If the charity fundraiser impacts on traffic flows or parking spaces, other permissions may be required from the Council.
- Charity stalls should clearly display the name of the collecting organisation and the charity, and carry their licence ready to show on request.
- Fundraising areas must be left clean and tidy.
- Stalls are generally only approved for the following areas:
  - Cuba Mall
  - Manners Mall
  - Civic Square
  - the corner of Lambton Quay and Hunter Street
  - the Railway Station.
- Cooking using an open flame, including 'sausage sizzles', are not allowed on public spaces.

- Organisations that run a lottery or raffle as part of their fundraising, or employ a promotional company to do so, may require a license issued by the Gaming Unit of the Department of Internal Affairs. If a license is needed, a copy must be included with the application.
- The Council may place additional special conditions on charity fundraiser stalls.

### **12.5 Applying for a street appeal or charity fundraiser stall licence**

All organisations or groups wanting to hold a street appeal or to set up a charity stall in a public space must first complete an application form and receive Council approval.

There is no fee for this licence.

The application must include:

- evidence of the organisation's legal structure and non-profit status (for the first application only)
- the proposed date of the street appeal or fundraiser stall, and that for any relevant national appeal of their organisation. Street appeals can be conducted on any day of an allocated week
- an estimate of the number of collectors and a summary of proposed collection location(s)
- a copy of any other licence required, such as from the Department of Internal Affairs.

## **13. Guidelines for street performance and busking**

### **13.1 Introduction**

Buskers and street performers help to enhance Wellington's reputation as the energetic and interactive, cultural and entertainment capital. The Council welcomes the opportunity to support high-quality street performances. It will take into account the needs of inner city residents, pedestrians and street performers. These guidelines have been developed to help performers, residents, pedestrians, retailers, workers and visitors understand the rules around performing on Wellington's streets, while still supporting a vibrant street performance culture.

### **13.2 Purpose and scope**

These guidelines outline the conditions for approval of street performances and busking on footpaths and other public spaces in the Wellington District. They form part of the Footpath Management Policy Guidelines, and must be read in conjunction with those guidelines.

### **13.3 Definitions**

**Busking** is street performance where performers accept money from the public.

**Circle acts** are performances lasting 20-40 minutes that encourage the audience to stop and watch or participate in the performance.

**Dangerous materials or objects** are materials and objects that could be a risk, or hazard to the public and performers.

- dangerous materials include flammable materials and chemicals, fire, fireworks, smoke, flares, heated elements, or anything giving off heat or toxicity that could harm or damage the public or the environment.
- dangerous objects include whips, knives, spears, swords, spikes, chainsaws and sharp objects of any kind that could harm the public or performer.

**Pitch** is a site where busking or street performance takes place. The size of the pitch is set by the boundaries of equipment, props, participants or movements that are part of the performance.

**Public places** are places in the city managed by Wellington City Council where busking is permitted. This includes streets, footpaths, pedestrian malls, squares, parks and the waterfront.

**Quiet performances** are performances with no noise associated with the performance such as amplification, musical instruments, singing, noise-making objects or speaking in a loud voice. They can involve up to four voices at a time, if the tone is conversational.

**Reasonable background noise** is an assessment made by Wellington City Council noise control officers when measuring the sound volume of a street performance. The assessment takes into account the location, time, day of week, weather and traffic conditions and other activities happening in the area.

**Sound performances** are performances involving amplification, musical instruments, singing, other noise-making objects (such as tools, chainsaws, sticks or motors), loud voices or more than four voices.

**Squatting or holding a pitch** occurs when a person occupies a performance site so they can perform there later. Including performance time, a pitch may be held for up to 2.5 hours in a day.

**Street performance or busking** is a performance in a public place, which usually involves requests for money. Performances include musical, theatrical, juggling, circus performance pavement art, speeches, poetry or doing other acts of a similar nature in public places.

**Roaming acts** are performances that do not take place in a single pitch/site but involve the performer(s) moving around and mingling with the public.

**Walkby acts** are spontaneous and can last much longer than a circle act and do not require the public to stop and watch.

### **13.4 Street performance licences**

Anyone performing or busking in any public place (unless employed for an approved event) must hold a current Wellington City Council street performance licence. Street performances may be licensed in public places where performances do not affect public safety and do not interfere with pedestrian or traffic flow, business activity, or residential living.

Provided they are not using dangerous materials or objects, performers employed for a scheduled street event approved, or organised, by the Council (including protests, community festivals and commercial promotions) do not need a street performance licence for that event. However, organisers of street events must ensure that the street performance standards are complied with, or obtain approval for exemption from the conditions.

Licences can be issued to individuals or groups. They cannot be transferred to other performers.

Street performers under twelve years of age need permission from a parent or guardian to apply for a street performance licence. Wellington City Council recommends that street performers under twelve be supervised by an adult at all times when performing.

The street performance licence is designed to protect both the performers and the public. Access to a street performance licence is unrestricted unless a performer does not comply with the conditions of the licence. The Council can cancel or refuse to issue a licence for any street performer they believe is not complying with the licence conditions.

Street performance involving dangerous materials or objects requires a special street performance permit. For information on how to obtain a special street performance permit, street performers should see the Code of Practice for Using Hazardous Materials in a Street Performance, below.

### **13.5 Applying for a licence**

Street performers can get a licence by going to any Council Service Centre, filling out an application form and showing proof of identity to staff. A licence will be issued straight away as long as the street performance activity complies with the relevant conditions.

Licences are free and valid for twelve months. After twelve months, street performers can apply for a new licence.

Special street performance permits are valid for three months from the date of issue.

### **13.6 Street performance conditions**

Street performers must display, or make available to Council officers or any member of the public on request, their street performance licence whenever they perform.

#### **13.6.1 Acceptable locations and times**

If a street performer is performing immediately outside retail premises, and is asked by the retailer to move on, they must do so.

Performance in the following locations can only take place with permission from the appropriate authority:

- Civic Square (Wellington City Council- 499-4444)
- Parks and reserves (Wellington City Council- 499-4444)
- Waterfront (Wellington Waterfront Limited- 495-7820)
- Te Papa forecourt (Te Papa Tongarewa – Museum of New Zealand-381-7000).

Quiet walk-by acts and quiet roaming acts may be performed at any time and in any public place in Wellington, including the Railway Station subway and forecourt, so long as all the street performance conditions are met.

Circle acts are only allowed in Cuba and Manners Malls, Courtenay Place, Oriental Parade, and the Railway Station subway and forecourt.

#### **13.6.2 Maintaining access**

Street performers or their audiences must not at any time block footpaths, shop doorways (during business hours), residential doorways, bus stops, corner crossing and pedestrian crossings, or fire escapes.

Performers must ensure that wheelchair access and the following minimum unobstructed footpath widths are maintained around the site in which they are performing:

- 4 metres for the Lambton Quay and Willis Street
- 3 metres for Manners Street, Manners Mall, Cuba Street, Cuba Mall and Courtenay Place
- 2 metres for all other locations in the wider city, that is, Wellington District.

#### **13.6.3 Sound performances**

Sound performances should not reach an unreasonable level of volume and should be considerate of pedestrians and the general public. The proposed activity must comply with any relevant rules of the District Plan, and, if required, the applicant must also apply for a Land Use Consent to undertake a commercial activity in a residential area. Council will consider how the proposed activity might adversely impact on the amenity of the area, with special regards to noise levels. As a

guide only, noise from any street performance should not be greater than reasonable background noise when heard from more than 30 metres, horizontally or vertically, from where the performance is taking place. For detailed requirements, applicants should refer to the District Plan standards.

The following special conditions apply to sound performances:

- sound performances that meet all street performance conditions are allowed in any public place in Wellington, between 7am and 9pm.
- sound performances that meet all street performance conditions are also allowed in the following locations between 9pm and 3am:
  - Courtenay Place from Cambridge Terrace to Tory Street
  - Cuba Mall from Manners Street to Dixon Street
  - the Railway Station subway and forecourt.
- sound performances should be separated by a minimum distance of 50 metres
- the Council reserves the right to place special conditions on sound condition permits such as maximum amplification for amplifiers and restrictions on drums and bag pipes
- after 9pm, sound performances should avoid setting up within 30 metres from residences, apartments, motels, hotels, hostels or any other form of accommodation. Sound performances that receive complaints from residences or accommodation facilities may be requested to setup in different locations through a special condition on the licence.

#### **13.6.4 Squatting or holding a pitch**

Access to favourable street performance pitches is to be fairly shared among buskers, to give residents, retailers and workers a variety of performance.

The maximum performance time is 90 minutes. Each performer or group of performers can occupy a site for a maximum time of 150 minutes, including no more than 90 minutes of performance, per day at any one site. Neither performance time nor site occupation needs to be continuous. The remaining 60 minutes of non-performance time is available for non-performance activities including setting up, breaks and packing down.

#### **13.6.5 Seeking audience donations**

Street performances are a valid way for people to make money but members of the public should not feel coerced to give money. Street performers can receive voluntary donations by holding a container or by placing a container on the ground. Street performers can have a written sign asking for donations and can ask the audience for donations but they cannot approach individuals for money.

Members of the public, including those with disabilities, have the right to have sufficient space to pause and enjoy a performance, or to safely pass it by. They also have the right to not give money to a street performer.

#### **13.6.6 Liability**

Street performers will be responsible for claims made against them for personal injury or property damage. Wellington City Council is protected by its insurance against legal liability arising from busking and street performance activities. Buskers and street performers are not protected by the Council's public liability insurance and are encouraged to hold their own public liability insurance.

### **13.6.7 Complaints**

If it is believed that a street performance does not comply with the Council's street performance licence conditions, a complainant can:

- talk to the performer(s) and explain what they want them to do differently (for example, perform somewhere else or perform more quietly). Street performers have a responsibility to co-operate if complaints are received from the public.
- ask to see the street performance licence and note the licence number so they can be contacted by the Council
- lay a complaint with the Council by ringing 499-4444. Council operators are available 24 hours a day.
- lay a complaint with Police (if the performer is drunk, violent, indecent, disorderly or behaving offensively).

When laying a complaint about a street performance or performer it is helpful if the following information is provided:

- the complainant's name and contact details
- the performer's name and licence number
- the time the performance started
- the type of performance
- the objections to the performance, or an explanation of how it is believed the performance is not complying with the Council's Street Performance and Busking Policy.

Once a complaint is received, a Council officer will investigate and take action as appropriate.

### **13.7 Guidelines for organising street events**

The following guidelines apply to organisers of street events:

- people organising street events including parades, festivals, marches, protests and the distribution of fliers or free samples are referred to section 17.3 of the Public Place Bylaw, and asked to inform the Council of their intentions. This is to enable the Council to share information about traffic management, potential risks to pedestrians or clashes with other activities
- if the event includes performance, the performers are not required to hold street performance licences as the organisers are responsible for ensuring the performance complies with the conditions in this guide. Organisers should ensure performers get a copy of the Council guidelines and make sure all performers understand the street performance conditions
- if the organiser wants a performance that will not comply with the street performance conditions, they must obtain written permission from the Council for exemption
- if the performance will involve dangerous materials or objects, the performers must hold a current Special Permit and comply with the Code of Practice
- for further information about planning an event that will impact on a road, see the 'Planning a Street Event' brochure available from Council Service Centres, or by contacting the Council on 499-4444.

## **13.8 Code of practice for use of dangerous materials and objects in a street performance**

### **13.8.1 Introduction**

Wellington City Council recognises that some street performers use dangerous materials and objects in their performances and that performances with these items are popular with the public.

The purpose of the Code of Practice is to ensure the use of dangerous materials and objects is restricted to street performers who have the necessary skills and experience in their use, and who maintain high safety standards for themselves and the public.

Performers can only use dangerous materials and objects if they hold a special permit to do so, and comply with the terms and conditions in the Code of Practice in addition to the conditions of a general street performance licence. Special street performance permits require peer endorsement from two peers approved by the Manager of Recreation Wellington.

### **13.8.2 Approved sites for using dangerous materials and objects**

There are three approved locations for street performance involving dangerous materials and objects: Cuba Mall, Manners Mall and the Courtenay Place circle. Performances with dangerous materials or objects can also take place in Civic Square, on the waterfront and in city parks with written permission from the appropriate authority.

### **13.8.3 Special street performance permits**

Street performers using dangerous materials and objects must hold a current special street performance permit to use these items in their acts. Special street performance permits are free of charge and valid for three months from the date of issue.

Special street performance permits require peer endorsement from two peer reviewers approved by the Wellington City Council. A performer renewing their permit within one year of expiry is not required to undergo the peer endorsement process. Organisers of festivals that include international street performers using dangerous materials or objects can obtain peer endorsement on behalf of a performer by providing references, and a detailed description of the show and an assessment of its safety standards.

### **13.8.4 Conditions for special street performance permits**

All general conditions applying to street performance licences also apply to the special street performance permits.

Special street performance permits are only issued to individual street performers, not groups. Each performer in a group who is to use dangerous materials or implements must hold a current special street performance permit.

Performers using dangerous materials or objects are required to be skilled and experienced in using these materials. They must also have an understanding of, and commitment to safety for the public, themselves, and the environment.

Wellington City Council reserves the right to withhold permission for street performances involving fire if a fire ban is in force in the city. A special street performance permit may be withdrawn if any of the conditions of the street performance licence or Code of Practice are not met. Any performer whose permit is withdrawn is not eligible to reapply for at least one year.

Street performers holding special street performance permits must have the permit with them while performing with dangerous material and objects, with the permit either on display or ready to show to any Council officer or member of the public who asks to see it.

The only flammable liquid/hazardous substance permitted in street performance acts is kerosene. No other flammable liquids or hazardous substances will be permitted.

Fireworks are not permitted in street performances.

Street performers holding a special street performance permit are responsible for the safety of themselves and their audience when using dangerous materials or objects in their acts. The use of fire and potentially dangerous implements, if approved, must not endanger the public, the performers, property or the environment.

They must:

- define the performance space by setting a visible boundary of at least two metres between the performer and the audience, using either a rope, chain or chalk line that is removed once the performer has completed the act
- include a fire blanket or fire extinguisher in their performance kits when using kerosene, and ensure it is visible and accessible throughout the performance
- store and transport any kerosene in portable, unbreakable, closed containers of a 5 litre maximum capacity and clearly labelled 'Kerosene /Poison'. A plastic squeeze bottle may assist with accurate fuel application
- prevent kerosene fuel from being dripped, tipped or flicked onto people, vegetation, or property. Any kerosene stains on ground surfaces must be removed immediately following the end of the performance
- alter all dangerous objects (including chain saws, knives, swords and mechanical devices) used in a performance by blunting to minimise any risk of piercing skin when direct pressure is applied.

### **13.8.5 Special street performance peer review**

Peer review is the process of discussing and / or viewing a performer's act. Peer review for safety is to assess whether a performer has considered safety and whether they are aware of basic safety principles. Because each performer is unique, the best way to assess the safety of an act is for a performer's peers to view it and give their opinion.

Peer review doesn't guarantee that an act is 100% safe but instead assesses whether a performer is aware of the risks of working with fire and other dangerous objects and committed to minimising those risks at all times.

Peer reviewers are experienced local performers. Two peer reviewers will meet with a performer to discuss the show and if necessary view part of the performance. Performers need to contact the peer reviewers to arrange a review time. Contact numbers for peer reviewers are on the special permit application form. Peer reviewers will try to assess all acts as quickly as possible.

A performer who does not pass the peer review for safety will not be permitted to perform in Wellington using dangerous materials or objects. They will still be able to perform without using dangerous materials or objects.

### **13.9 Additional information**

Further information is available via the Wellington City Council Call Centre at 499 4444 regarding:

- street performance or busking licences, special permits, participating in scheduled night time street events or organising a street event
- community grants and funding criteria, or for assistance and advice in preparing grant applications. Community groups interested in developing street performance shows or

workshops for young people to learn performance skills may be eligible for grants for Arts and Culture, or Community or Youth Development.

- youth events, or about how street performers can support community groups and help young people to devise street performances
- commenting on the street performance policy, or complaining about a street performance or busker.